



Oxford

aviation academy

FOURTH
EDITION

Complies with
EASA ATPL

SKILLS · FOR · FLIGHT

ATPL GROUND TRAINING SERIES

Air Law

Air Law

Rules of the Air

Air Traffic Services

Aerodromes

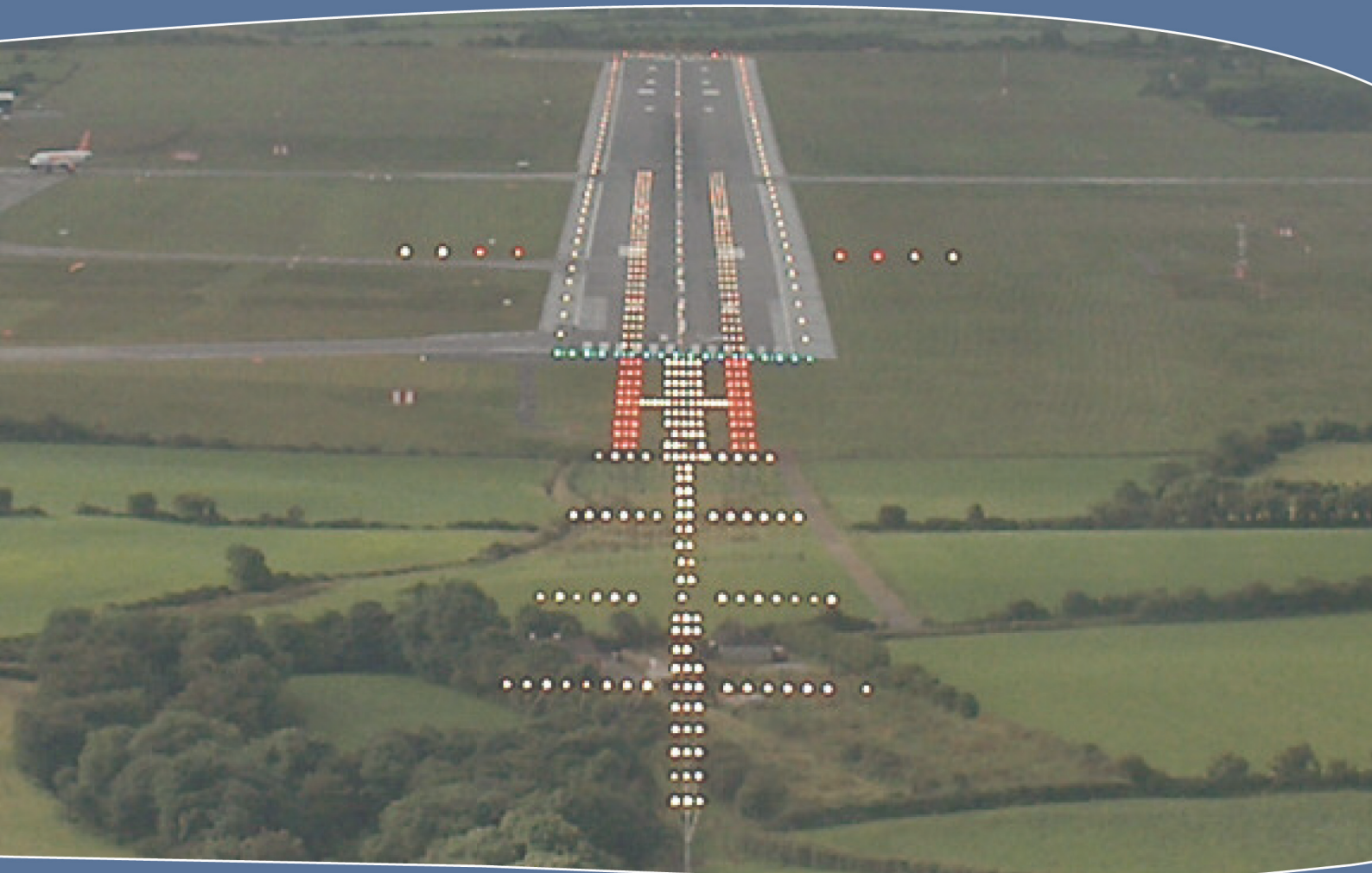

Complies with JAA/EASA ATPL syllabus

Created by



Suitable for students studying for the
ATPL Theoretical Examinations

Contains specimen examination and test questions and answers

1

© Oxford Aviation Academy (UK) Limited 2008
All Rights Reserved

This text book is to be used only for the purpose of private study by individuals and may not be reproduced in any form or medium, copied, stored in a retrieval system, lent, hired, rented, transmitted or adapted in whole or in part without the prior written consent of Oxford Aviation Academy.

Copyright in all documents and materials bound within these covers or attached hereto, excluding that material which is reproduced by the kind permission of third parties and acknowledged as such, belongs exclusively to Oxford Aviation Academy.

Certain copyright material is reproduced with the permission of the International Civil Aviation Organisation, the United Kingdom Civil Aviation Authority and the European Aviation Safety Agency (EASA).

This text book has been written and published as a reference work to assist students enrolled on an approved EASA Air Transport Pilot Licence (ATPL) course to prepare themselves for the EASA ATPL theoretical knowledge examinations. Nothing in the content of this book is to be interpreted as constituting instruction or advice relating to practical flying.

Whilst every effort has been made to ensure the accuracy of the information contained within this book, neither Oxford Aviation Academy nor the distributor gives any warranty as to its accuracy or otherwise. Students preparing for the EASA ATPL theoretical knowledge examinations should not regard this book as a substitute for the EASA ATPL theoretical knowledge training syllabus published in the current edition of 'EASA-FCL 1 Flight Crew Licensing (Aeroplanes)' (the Syllabus). The Syllabus constitutes the sole authoritative definition of the subject matter to be studied in an EASA ATPL theoretical knowledge training programme. No student should prepare for, or is currently entitled to enter himself/herself for the EASA ATPL theoretical knowledge examinations without first being enrolled in a training school which has been granted approval by an EASA authorised national aviation authority to deliver EASA ATPL training.

Oxford Aviation Academy excludes all liability for any loss or damage incurred or suffered as a result of any reliance on all or part of this book except for any liability for death or personal injury resulting from Oxford Aviation Academy's negligence or any other liability which may not legally be excluded.

Cover Photograph: Approach in to Cork (EICK) Eire

Photographed by L ten Hoopen

This edition distributed by Transair (UK) Ltd, Shoreham, England: 2008
Printed in Singapore by KHL Printing Co. Pte Ltd

Textbook Series

Book	Title	EASA Ref. No.	Subject
1	010 Air Law	010	
2	020 Aircraft General Knowledge 1	021 01	Airframes & Systems
		021 01 01-04	Fuselage, Wings & Stabilising Surfaces
		021 01 05	Landing Gear
		021 01 06	Flight Controls
		021 01 07	Hydraulics
		021 01 08-09	Air Systems & Air Conditioning
		021 01 10	Anti-icing & De-icing
		021 01 11	Fuel Systems
		021 04 00	Emergency Equipment
3	020 Aircraft General Knowledge 2	021 02	Electrics – Electronics
		021 02 01	Direct Current
		021 02 02	Alternating Current
		021 02 05	Basic Radio Propagation.
4	020 Aircraft General Knowledge 3	021 00	Powerplant
		021 03 01	Piston Engines
		021 03 02	Gas Turbines
5	020 Aircraft General Knowledge 4	022	Instrumentation
		022 01	Flight Instruments
		022 03	Warning & Recording
		022 02	Automatic Flight Control
		022 04	Power Plant & System Monitoring Instruments
6	030 Flight Performance & Planning 1	031	Mass & Balance
		032	Performance
7	030 Flight Performance & Planning 2	033	Flight Planning & Monitoring
8	040 Human Performance & Limitations	040	
9	050 Meteorology	050	
10	060 Navigation 1	061	General Navigation
11	060 Navigation 2	062	Radio Navigation
12	070 Operational Procedures	070	
13	080 Principles of Flight	080	
14	090 Communications	091	VFR Communications
		092	IFR Communications

Book Contents

DEFINITIONS 1

INTERNATIONAL AGREEMENTS AND ORGANISATIONS 19

AIRWORTHINESS OF AIRCRAFT. 47

AIRCRAFT NATIONALITY AND REGISTRATION MARKS. 53

FLIGHT CREW LICENSING 61

RULES OF THE AIR 85

INSTRUMENT PROCEDURES - DEPARTURES 131

APPROACH PROCEDURES 145

CIRCLING APPROACH 177

HOLDING PROCEDURES 185

ALTIMETER SETTING PROCEDURES 195

PARALLEL OR NEAR-PARALLEL RUNWAY OPERATION. 207

SSR AND ACAS 221

AIRSPACE 229

AIR TRAFFIC SERVICES 245

SEPARATION. 263

CONTROL OF AIRCRAFT 297

AERONAUTICAL INFORMATION SERVICE (AIS). 323

AERODROMES PHYSICAL CHARACTERISTICS. 341

AERODROMES VISUAL AIDS MARKINGS AND SIGNS 363

AERODROME LIGHTING 389

AERODROME SERVICES AND OBSTACLE MARKING 409

FACILITATION. 423

SEARCH AND RESCUE. 431

SECURITY. 441

AIRCRAFT ACCIDENT AND INCIDENT INVESTIGATION 455

REVISION QUESTIONS. 465

CHAPTER ONE

DEFINITIONS

Contents

INTRODUCTION	3
AIR LAW.....	3
ABBREVIATIONS	3
DEFINITIONS	6

INTRODUCTION

The content of the Oxford Aviation College Aviation Law course meets the requirements of the JAA-FCL syllabus (Subject 010- Air Law) and the associated Learning Objectives (LOs). The main reference documents are the Annexes to the Convention on International Aviation (The Chicago Convention) and the associated PANS documents. Additional references are taken from JAR FCL and JAR OPS.

AIR LAW

The subject of Air Law is a misnomer. The content of the subject is effectively airmanship with the addition of information concerning some of the international conventions that have been adopted to regularise the administration of aviation and the aviation industry. The subject matter is diverse ranging from international agreements through the rules of the air, flight crew licensing, instrument procedures, ATC and the physical characteristics of aerodromes. A student does not need to be a lawyer to pass this subject. Most of the requirements are common sense, the majority of which will be familiar to a PPL holder. The ab initio student should approach the subject from the 'need to know' principle and be guided by the examination feedback as well as the syllabus. The end of chapter questions are based on examination questions and should give the student a feel for the level of knowledge required on completion of the course.

ABBREVIATIONS

Air Law, perhaps more than any other subject, is inundated with abbreviations, some of which are examinable. Where this is the case, the abbreviations are specified in the appropriate chapter and 'decoded.' The following is a list (not exhaustive) of abbreviations commonly used in aviation.

AAIB	Air Accident Investigation Board
AAL	Above Aerodrome Level
ABN	Aerodrome Beacon
A/c	Aircraft
ACC	Area Control Centre
ADA	Advisory Airspace
ADF	Automatic Direction Finding
ADR	Advisory Route
ADT	Approved Departure Time
AFI	Assistant Flying Instructor
AFIS	Aerodrome Flight Information Service
AFS	Aeronautical Fixed Service
AFTN	Aeronautical Fixed Telecommunications Network
AGL	Above Ground Level
AIC	Aeronautical Information Circular
AIP	Aeronautical Information Publication
AIREP	Air Report
AIS	Aeronautical Information Service
AME	Authorised Medical Examiner
AMSL	Above Mean Sea Level
ANO	Air Navigation Order
AOC	Air Operator's Certificate
ARP	Aerodrome Reference Point
ARN	ATS Route Network

ASDA	Accelerate-Stop Distance Available
ASR	Altimeter Setting Region
ATAS	Air Traffic Advisory Service
ATC	Air Traffic Control
ATCC	Air Traffic Control Centre
ATCU	Air Traffic Control Unit
ATCRU	Air Traffic Control Radar Unit
ATFM	Air Traffic Flow Management
ATIS	Automatic Terminal Information Service
ATS	Air Traffic Service
ATSU	Air Traffic Service Unit
ATZ	Air Traffic Zone
AUW	All up weight
AWD	Airworthiness Division
AWY	Airway
CAA	Civil Aviation Authority
CANP	Civil Aviation Notification Procedure
CAS	Controlled Airspace
C of A	Certificate of Airworthiness
CTR	Control Zone
DA	Decision Altitude
DF	Direction Finding
DH	Decision Height
DME	Distance Measuring Equipment
DR	Dead Reckoning
EAT	Expected Approach Time
ECAC	European Civil Aviation Authority
ED	Emergency Distance
EET	Estimated Elapse Time
ELT	Emergency Location Transmitter
EPIRB	Emergency Position Indicating Radio Beacon
ETA	Estimated Time of Arrival
ETOPS	Extended Twin Jet Operations
FAL	Facilitation of Air Transport
FCL	Flight Crew Licensing
FI	Flying Instructor
FIR	Flight Information Region
FIS	Flight Information Service
FL	Flight Level
FLPFM	Foot Launched Powered Flying Machine
FTL	Flight Time Limitations
GASIL	General Aviation Safety Information Leaflet
GCA	Ground Controlled Approach
H24	Day and Night Operating Hours
HF	High Frequency
Hz	Hertz Radio Frequency
IAS	Indicated Air Speed
Ibn	Identification Beacon
ICAO	International Civil Aviation Organisation
IFR	Instrument Flight Rules
ILS	Instrument Landing System
IMC	Instrument Meteorological Conditions
IR	Instrument Rating
IRE	Instrument Rating Examiner
IRVR	Instrument Runway Visual Range

ISA	International Standard Atmosphere
JAA	Joint Aviation Authority
JAR	JAA Regulations
KHz	Kilo Hertz
Kt	Knots
LARS	Lower Airspace Radar Service
LATCC	London Air Traffic Control Centre
LDA	Landing Distance Available
LF	Low Frequency
MATZ	Military Air Traffic Zone
MDH	Minimum Descent Height
MEHT	Minimum Eye Height (PAPIs)
MEL	Minimum Equipment List
METAR	Aviation Routine Weather Report
MF	Medium Frequency
MHz	Megahertz
MNPS	Minimum Navigation Performance Specification
MoD	Ministry of Defence
MOTNE	Meteorological Operational Telecommunications Network
MRSA	Mandatory Radar Service Area
MTOM	Maximum Take-off Mass
MTWA	Maximum Take-off Weight Authorised
NAPs	Noise Abatement Procedures
NATS	National Air Traffic Services
NDB	Non-Directional Beacon
NOH	Notified Operating Hours
NOSIG	No Significant Change
NOTAM	Notice to Airmen
OCA	Oceanic Control Area
OCA	Obstacle Clearance Altitude
OCH	Obstacle Clearance Height
OCL	Obstacle Clearance Limit
OIS	Obstacle Identification Surface
PANS	Procedures for Air Navigation
PAR	Precision Approach Radar
PAPI	Precision Approach Path Indicator
Pax	Passengers
PIC	Pilot in Charge
PT	Public Transport
RCC	Rescue Co-ordination Centre
RIS	Radar Information Service
RLCE	Request level change en-route
RNOTAM	Royal NOTAM
RTF	Radio Telephony
RTOW	Regulated Take-off Weight
RTG	Radio Telegraphy
RVR	Runway Visual Range
RVSM	Reduced Vertical Separation Minima
Rwy	Runway
SAR	Search and Rescue
SARP	Standard and Recommended Practice (ICAO)
SARSAT	Search and Rescue Satellite Tracking System
SELCAL	Selective Calling
Sfc	Surface
SID	Standard Instrument Departure

SIGMET	Significant Meteorological Warning
SNOCLO	Closed by Snow
SPECI	Special Met Report
SPL	Supplementary Flight Plan
SSR	Secondary Surveillance Radar
STAR	Standard Instrument Arrival
SVFR	Special Visual Flight Rules
TAF	Aerodrome Meteorological Forecast
TAS	True Airspeed
TCA	Terminal Control Area
TMA	Terminal Maneuvering Area
TODA	Take-off Distance Available
TOM	Take-off Minima
TORA	Take-off Run Available
TR	Type Rating
TRE	Type Rating Examiner
TL	Transition Level
TVOR	Terminal VHF Omni Ranging
Twr	Tower (Aerodrome Control)
UHF	Ultra High Frequency
UIR	Upper Information Region
U/s	Unserviceable
UTC	Co-ordinated Universal Time
VASI	Visual Approach Slope Indicator
VFR	Visual Flight Rules
VHF	Very High Frequency
VMC	Visual Meteorological Conditions
VOR	VHF Omni-ranging
VSTOL	Very Short Take-off and Landing
WEF	With effect from
WIP	Work in Progress
Wpt	Waypoint

DEFINITIONS

Some of the examination questions relate to the wording of definitions and the LOs require the student to be able to identify the correct definition from a list of offered alternatives. The following are the definitions used in the Annexes to the Convention on International Civil Aviation.

Advisory Airspace. Airspace of defined dimensions, or designated route, within which air traffic advisory service is available.

Advisory Route. A designated route along which air traffic advisory service is available.

Aerial Work Aircraft means an aircraft (other than a public transport aircraft) flying, or intended by the operator to fly, for the purpose of aerial work.

Aerial Work. Undertaking means an undertaking whose business includes the performance of aerial work.

Aerobatic Manoeuvres includes loops, spins, rolls, bunts, stall turns, inverted flying and any other similar manoeuvre.

Aerodrome means any area of land or water designed, equipped, set apart or commonly used for affording facilities for the landing and departure of aircraft and includes any area or space, whether on the ground, on the roof of a building or elsewhere, which is designed, equipped or set apart for affording facilities for the landing and departure of aircraft capable of descending or climbing vertically, but shall not include any area the use of which for affording facilities for the landing and departure of aircraft has been abandoned and has not been resumed.

Aerodrome Control Service means an air traffic control service for any aircraft on the manoeuvring area or apron of the aerodrome in respect of which the service is being provided or which is flying in, or in the vicinity of, the aerodrome traffic zone of that aerodrome by visual reference to the surface.

Aerodrome Flight Information Unit means a person appointed by the Authority or by any other person maintaining an aerodrome to give information by means of radio signals to aircraft flying or intending to fly within the aerodrome traffic zone of that aerodrome and aerodrome flight information service shall be construed accordingly.

Aerodrome. A defined area on land or water (including any buildings, installations and equipment) intended to be used either wholly or in part for the arrival, departure and surface movement of aircraft.

Aerodrome Control Tower. A unit established to provide air traffic control service to aerodrome traffic.

Aerodrome Operating Minima in relation to the operation of an aircraft at an aerodrome means the cloud ceiling and runway visual range for take-off, and the decision height or minimum descent height, runway visual range and visual reference for landing, which are the minimum for the operation of that aircraft at that aerodrome.

Aerodrome Traffic. All traffic on the manoeuvring area of an aerodrome and all aircraft flying in the vicinity of an aerodrome.

Aerodrome Traffic Zone. Airspace of defined dimensions established around an aerodrome for the protection of aerodrome traffic.

Aeronautical Ground Light means any light specifically provided as an aid to air navigation, other than a light displayed on an aircraft.

Aeronautical Part. That part of an aerodrome including buildings to which access is limited by security measures (airside).

Aeronautical Radio Station means a radio station on the surface, which transmits or receives signals for the purpose of assisting aircraft.

Aeronautical Station. A land station in the aeronautical mobile service. In certain instances, an aeronautical station may be located, for example, on board ship or on a platform at sea.

Aeroplane. A power driven heavier than air aircraft, deriving its lift in flight chiefly from aerodynamic reactions on surfaces which remain fixed under given conditions of flight.

Aircraft. Any machine that can derive support in the atmosphere from the reactions of the air other than the reactions of the air against the earth's surface.

Aircraft Category. Classification of aircraft according to specified basic characteristics e.g. aeroplane, helicopter, glider, free balloon.

Aircraft certified for single pilot operation. A type of aircraft which the State of Registry has determined, during the certification process, can be operated safely with a minimum crew of one pilot.

Aircraft - Type of. All aircraft of the same basic design including all modifications thereto except those modifications which result in change in handling or flight characteristics

Air Traffic. All aircraft in flight or operating on the manoeuvring area of an aerodrome.

Air Traffic Advisory Service. A service provided within advisory airspace to ensure separation, in so far as practical, between aircraft which are operating on IFR flight plans.

Air Traffic Control Clearance Authorisation for an aircraft to proceed under conditions specified by an air traffic control unit.

Note. For convenience, the term "air traffic control clearance" is frequently abbreviated to "clearance" when used in appropriate contexts.

Note 2. - The abbreviated term "clearance" may be prefixed by the words "taxi", "take-off", "departure", "en-route", "approach" or "landing" to indicate the particular portion of flight to which the air traffic control clearance relates.

Air Traffic Control Service. A service provided for the purpose of:

- Preventing collisions:
 - Between aircraft
 - On the manoeuvring area between aircraft and obstructions
- Expediting and maintaining an orderly flow of air traffic.

Air Traffic Control Unit. A generic term meaning variously, area control centre, approach control office or aerodrome control tower.

Air Traffic Services Airspaces. Airspaces of defined dimensions alphabetically designated, within which specific types of flights may operate and for which air traffic services and rules of operation are specified.

Air Traffic Services Reporting Office. A unit established for the purpose of receiving reports concerning air traffic services and flight plans submitted before departure.

Note. An air traffic reporting office may be established as separate unit or combined with an existing unit, such as another air traffic services unit, or a unit of the aeronautical information

Air Traffic Services Unit. A generic term meaning variously, air traffic control unit, flight information centre or air traffic services reporting office.

Air Transport Undertaking means an undertaking whose business includes the undertaking of flights for the purposes of public transport of passengers or cargo.

Airborne Collision Avoidance System (ACAS). An aircraft system based on secondary surveillance radar (SSR) transponder signals which operates independently of ground-based equipment to provide advice to the pilot on potential conflicting aircraft that are equipped with SSR transponders.

Airway. A control area or portion thereof established in the form of a corridor equipped with radio navigation aids.

Alerting Service. A service provided to notify appropriate organisations regarding aircraft in need of search and rescue aid, and to assist such organisations as required.

Alternate Aerodrome. An aerodrome to which an aircraft may proceed when it becomes either impossible or inadvisable to continue to or to land at, the aerodrome of intended landing. Alternate aerodromes include the following:

- Take-off alternate. An aerodrome to which an aircraft can land should this become necessary shortly after take-off where it is not possible to use the aerodrome of departure.
- En-route alternate. An aerodrome at which an aircraft would be able to land after experiencing an abnormal or emergency condition while en route.
- Destination alternate. An aerodrome to which an aircraft may proceed should it become either impossible or inadvisable to land at the aerodrome of intended landing.

Note. The aerodrome from which a flight departs may also be en-route or a destination alternate aerodrome for that flight.

Altitude. The vertical distance of a level, a point or an object considered as a point, measured from mean to sea level.

Annual Costs in relation to the operation of an aircraft means the best estimate reasonably practicable at the time of a particular flight in respect of the year commencing on the first day of January preceding the date of the flight, of the cost of keeping and maintaining and the indirect costs of operating the aircraft, such costs in either case excluding direct costs and being those actually and necessarily incurred without a view to profit.

Annual Flying Hours. The best estimate reasonably practicable at the time of a particular flight by an aircraft of the hours flown or to be flown by the aircraft in respect of the year commencing on the first day of January preceding the date of the flight.

Approach Control Office. A unit established to provide air traffic control service to controlled flights arriving at, or departing from, one or more aerodromes.

Approach Control Service. Air traffic control service for arriving or departing controlled flights.

Approach to Landing means that portion of the flight of the aircraft, when approaching to land, in which it is descending below a height of 1000 ft above the relevant specified decision height or minimum descent height.

Appropriate ATS Authority. The relevant authority designated by the State responsible for providing air traffic services in the airspace concerned.

Appropriate Authority.

- Regarding flight over the high seas; the relevant authority of the State of Registry
- Regarding flight other than over the high seas: the relevant authority of the State having sovereignty over the territory being overflown

Apron. A defined area, on a land aerodrome, intended to accommodate aircraft for the purposes of loading or unloading passengers, mail or cargo, fuelling, parking or maintenance.

Area Control Centre. An air traffic control unit established to provide an area control service to aircraft flying within a notified flight information region which are not receiving an aerodrome control service or an approach control service.

Area Control Service. Air traffic control service for controlled flights in control areas.

Area Navigation Equipment (RNAV). Equipment carried on board an aircraft which enables the aircraft to navigate on any desired flight path within the coverage of appropriate ground based navigation aids or within the limits of that on-board equipment or a combination of the two.

ATS Route. A specified route designed for channeling the flow of traffic as necessary for the provision of air traffic services.

Note. The term "ATS route" is used to mean variously, airway, advisory route, controlled or uncontrolled route, arrival or departure route, etc.

Authorised Person means:

- Any constable
- Any person authorised by the Secretary of State (whether by name, or by class or description) either generally or in relation to a particular case or class of cases
- Any person authorised by the Authority (whether by name or class or description) either generally or in relation to a particular case or class of cases

Cabin Attendant in relation to an aircraft means a person on a flight for the purpose of public transport carried for the purpose of performing in the interests of the safety of passengers duties to be assigned by the operator or the commander of the aircraft but who shall not act as a member of the flight crew.

Captive Flight means flight by an uncontrollable balloon during which it is attached to the surface by a restraining device.

Cargo includes mail and animals.

Certified for single pilot operation means an aircraft which is not required to carry more than one pilot by virtue of one or more of the following.

Change-over Point. The point at which an aircraft navigating on an ATS route segment defined by reference to very high frequency omni directional radio ranges (VOR) is expected to transfer its primary navigational reference from the facility behind the aircraft to the next facility ahead of the aircraft.

Note. Change-over points are established to provide the optimum balance in respect of signal strength and quality between facilities at all levels to be used and to ensure a common source of azimuth guidance for all aircraft operating along the same portion of a route segment.

Clearance Limit. The point to which an aircraft is granted an air traffic control clearance.

Cloud Ceiling in relation to an aerodrome means the vertical distance from the elevation of the aerodrome to the lowest part of any cloud visible from the aerodrome which is sufficient to obscure more than one-half of the sky so visible.

Commander in relation to an aircraft means the member of the flight crew designated as commander of that aircraft by the operator thereof, or, failing such a person, the person who is for the time being the pilot in command of the aircraft.

Commercial Pilot Licence (CPL). A licence held by a professional pilot which permits the holder to:

- Exercise all the privileges of a PPL
- Act as PIC in any aeroplane engaged in operations other than commercial air transport
- Act as PIC in commercial air transport in any aeroplane certificated for single pilot operation
- To act as co-pilot in commercial air transport in aeroplanes required to be operated with a co-pilot

Competent Authority. The authority responsible under the law of the State for promoting the safety of civil aviation.

Contracting State means any state which is party to the Convention on International Civil Aviation signed at Chicago on the 7 December 1944.

Control Area. A controlled airspace extending upwards from a specified limit above the earth.

Controlled Aerodrome. An aerodrome at which air traffic control service is provided to aerodrome traffic.

Note. The term "controlled aerodrome" indicates that air traffic control service is provided to aerodrome traffic but does not necessarily imply that a control zone exists.

Controlled Airspace. An airspace of defined dimensions within which air traffic control service is provided to IFR flights and to VFR flights in accordance with the airspace classification.

Note. Controlled airspace is a generic term which covers ATS airspace Classes A, B, C, D and E.

Controlled Flight. Any flight which is subject to an air traffic control clearance.

Control Zone. A controlled airspace extending upwards from the surface of the earth to a specified upper limit.

Configuration (as applied to the aeroplane). A particular combination of the positions of the moveable elements, such as wing flaps, landing gear, etc., which affect the aerodynamics of the aeroplane.

Co-pilot. A licenced pilot serving in any piloting capacity other than as pilot-in-command but excluding a pilot who is on board the aircraft for the sole purpose of receiving flight instruction.

CPL (Current Flight Plan). The Flight Plan, including changes if any, brought about by subsequent clearances.

Crew means a member of the flight crew, a person carried on the flight deck who is appointed by the operator of the aircraft to give or to supervise the training, experience, practice and periodical tests as required and in respect of the flight crew or as a cabin attendant.

Critical Power-Units(s). The power-unit(s), failure of which gives the most adverse effect on the aircraft characteristics relative to the case under consideration.

Cruise Climb. An aeroplane cruising technique resulting in a net increase in altitude as the aeroplane mass decreases.

Cruising Level. A level maintained during a significant portion of a flight.

Danger Area. An airspace of defined dimensions within which activities dangerous to the flight of aircraft may exist at specified times.

Day means the time from half an hour before sunrise until half an hour after sunset (both times exclusive), sunset and sunrise being determined at surface level.

Decision Height in relation to the operation of an aircraft at an aerodrome means the height in a precision approach at which a missed approach must be initiated if the required visual reference to continue that approach has not been established.

Declared Distances has the meaning which has been notified.

Design Landing Mass. The maximum mass of the aircraft at which, for structural design purposes, it is assumed to be planned to land.

Design Take-off Mass. The maximum mass at which the aircraft, for structural design purposes, is assumed to be planned to be at the start of the take-off run.

Design Taxiing Mass. The maximum mass of the aircraft, at which the structural provision is made for load liable to occur during the use of the aircraft, on the ground prior to the start of take-off.

Destination Alternate. An alternate aerodrome to which an aircraft may proceed should it become either impossible or inadvisable to land at the aerodrome of intended landing.

Dual Instruction Time. Flight time during which a person is receiving flight instruction from a properly authorised pilot on board the aircraft.

En-route Clearance. Where an ATC clearance is issued for the initial part of a flight solely as a means of expediting departing traffic, the subsequent clearance to the aerodrome of intended landing is an en-route clearance.

Estimated Off Blocks Time. The estimated time at which the aircraft will commence movement associated with departure.

Estimated Time of Arrival. For IFR flights, the time at which it is estimated that the aircraft will arrive over that designated point, defined by reference to navigation aids, from which it is intended that an instrument approach procedure will be commenced, or, if no navigation aid is associated with the aerodrome, the time at which the aircraft will arrive over the aerodrome.

Expected Approach Time. The time at which ATC expects that an arriving aircraft, following a delay, will leave the holding point to complete its approach to landing. Note.-The actual time of leaving a holding point will depend **on the approach clearance**.

Final approach and take-off area/FATO (except helicopters). A defined area over which the final phase of the approach manoeuvre to hover or landing is completed and from which the take-off manoeuvre is commenced and, where the FATO is to be used by performance class 1 helicopters, includes the rejected take-off area available.

Filed Flight Plan. The flight plan as filed with an ATS unit by the pilot or a designated representative, without any subsequent changes.

Note. When the word "message" is used as a suffix to this term, it denotes the content and format of the filed flight plan data as transmitted.

Flight Crew Member. A licensed crew member charged with duties essential to the operation of an aircraft during flight time.

Flight Information Service. A service provided for the purpose of giving advice and information useful for the safe and efficient conduct of flights.

Flight Level. A surface of constant atmospheric pressure which is related to a specific pressure datum, 1013.2 hPa, and is separated from other such surfaces by specific pressure intervals.

Note 1. A pressure type altimeter calibrated in accordance with the Standard Atmosphere:

- When set to QNH, altimeter will indicate altitude
- When set to QFE, altimeter will indicate height above the QFE reference datum
- When set at a pressure of 1013.2 hPa, may be used to indicate flight levels

Note 2. The terms "height" and "altitude, used in Note 1 above, indicate altimetric rather than geometric heights or altitudes.

Flight Plan. Specified information provided to air traffic services units, relative to an intended flight or portion of a flight of an aircraft.

Flight Procedures Trainer. See Synthetic flight trainer.

Flight Simulator. See Synthetic flight trainer.

Flight Recording System means a system comprising either a flight data recorder or a cockpit voice recorder or both.

Flight Time. The total time from the moment an aircraft first moves under its own power for the purpose of taking off until the moment it first comes to rest at the end of the flight.

Note 1. Flight time as here defined is synonymous with the term "block to block" time or "chock to chock" time in general usage which is measured from the time an aircraft moves from the loading point until it stops at the unloading point.

Note 2. Whenever helicopter rotors are engaged, the time will be included in the flight time.

Flight Time as Student Pilot in Command. Flight time during which the flight instructor will only observe the student acting as PIC and shall not influence or control the flight of the aircraft.

Flight Visibility. The visibility forward from the cockpit of an aircraft in flight.

Free Balloon means a balloon which when in flight is not attached by any form of restraining device to the surface.

Free Controlled Flight means flight during which a balloon is not attached to the surface by any form of restraining device (other than a tether not exceeding 5 metres in length which may be used as part of the take-off procedure) and during which the height of the balloon is controllable by means of a device attached to the balloon and operated by the commander of the balloon or by remote control.

Ground Visibility. The visibility at an aerodrome, as reported by an accredited observer.

Government Aerodrome means any aerodrome in the United Kingdom which is in the occupation of any Government Department or visiting force.

Heading. The direction in which the longitudinal axis of an aircraft is pointed, usually expressed in degrees from North (true, magnetic, compass or grid).

Height. The vertical distance if a level, a point or an object considered as a point, measured from a specified datum.

IFR. The symbol used to designate the instrument flight rules.

IFR Flight. A flight conducted in accordance with the instrument flight rules.

IMC. The symbol used to designate instrument meteorological conditions.

Instrument Approach Procedure. A series of predetermined manoeuvres by reference to flight instruments with specified protection from obstacles from the initial approach fix, or where applicable, from the beginning of a defined arrival route to a point from which a landing can be completed and thereafter, if a landing is not completed, to a position at which holding or en-route clearance criteria apply.

Instrument Meteorological Conditions. Meteorological conditions expressed in terms of visibility, distance from cloud, and ceiling, less than the minima specifies for visual meteorological conditions.

Note. In a control zone, a VFR flight may proceed under instrument meteorological conditions of and as authorised by air traffic control.

Instrument Flight Time. Time during which a pilot is piloting an aircraft solely by reference to instruments and without external reference points.

Instrument Ground Time. Time during which a pilot is practising, on the ground, simulated instrument flight in a synthetic flight trainer approved by the Licensing Authority.

Instrument time. Instrument flight time or instrument ground time.

JAA means the Joint Aviation Authorities, an associated body of the European Civil Aviation Conference.

JAR means a joint aviation requirement of the JAA bearing that number as it has effect under the Technical Harmonisation Regulation and reference to a numbered JAR is a reference to such a requirement.

Landing Area. That part of a movement area intended for the landing or take-off of aircraft.

Landing Surface. That part of the surface of an aerodrome which the aerodrome authority has declared available for the normal ground or water run of aircraft landing in a particular direction.

Level. A generic term relating to the vertical position of an aircraft in flight and meaning variously, height, altitude or flight level.

Lifejacket includes any device designed to support a person individually in or on the water.

Log Book in the case of an aircraft log book, engine log book or variable pitch propeller log book, or personal flying log book includes a record kept either in a book, or by any other means approved by the Authority in the particular case.

Manoeuvring Area. That part of an aerodrome to be used for the take-off, landing and taxiing of aircraft, excluding aprons.

Maintenance. Tasks required to ensure the continued airworthiness of an aircraft including any one or combination of overhaul, repair, inspection, replacement, modification or defect rectification.

Medical Assessment. The evidence issued by a Contracting State that the licence holder meets specific requirements of medical fitness. It is issued following an evaluation by the Licensing Authority of the report submitted by the designated medical examiner who conducted the examination of the applicant for the licence.

Minimum Descent Height in relation to the operation of an aircraft at an aerodrome means the height in a non-precision approach below which descent may not be made without the required visual reference.

Multiple Pilot Aeroplanes. Aeroplanes certificated for operation with a minimum crew of at least two pilots.

Multi-crew Co-operation. The function of the flight crew as a team of co-operating members led by the pilot-in-command.

Movement Area. That part of an aerodrome to be used for the take-off, landing and taxiing of aircraft, consisting of the manoeuvring area and the apron(s).

Nautical mile means the International Nautical Mile, that is to say, a distance of 1852 metres.
Night. The hours between the end of evening civil twilight and the beginning of morning civil twilight or such other period between sunset and sunrise, as may be prescribed by the appropriate authority.

Note. Civil twilight ends in the evening when the centre of the sun's disc is 6 degrees below the horizon and begins in the morning when the centre of the sun's disc is 6 degrees below the horizon.

Non-precision Approach means an instrument approach using non-visual aids for guidance in azimuth or elevation but which is not a precision approach.

Private Pilot's Licence (PPL). The licence held by a pilot which prohibits the piloting of an aircraft for which remuneration is given.

(To) Pilot. To manipulate the flight controls of an aircraft during flight time.

Pilot-In-Command. The pilot responsible for the operation and safety of the aircraft during flight time.

Power-unit. A system of one or more engines and ancillary parts which are together necessary to provide thrust, independently of the continued operation of any other power unit(s), but not including short period thrust-producing devices.

Precision approach means an instrument approach using Instrument Landing System, Microwave Landing System or Precision Approach Radar for guidance in both azimuth and elevation.

Pressure altitude. An atmospheric pressure expressed in terms of altitude which corresponds to the pressure in the Standard Atmosphere.

Proficiency Check. Demonstration of skill to revalidate or renew ratings, and including such oral examinations as the examiner may require.

Prohibited Area. An airspace of defined dimensions above the land areas or territorial waters of a State within which flight of aircraft is prohibited.

Rating. An authorisation entered on or associated with a licence and forming part thereof, stating special conditions, privileges or limitations pertaining to such licence.

Renewal. The administrative action taken after a rating has expired.

Rendering a Licence Valid. The action taken by a Contracting State, as an alternative to issuing its own licence, in accepting a licence issued by any other state as an equivalent of its own licence.

Repetitive Flight Plan (RPL). A flight plan related to a series of frequently recurring, regularly operated individual flights with identical basic features, submitted by an operator for retention and repetitive use by ATS units.

Reporting Point. A specified geographical location in relation to which the position of an aircraft can be reported.

Restricted Area. An airspace of defined dimensions above the land areas or territorial waters of a State within which flight of aircraft is restricted in accordance with certain specified conditions.

Re-validation. The administrative action taken within the period of validity of a rating or approval that allows the holder to continue to exercise the privileges of a rating or approval for a further specified period consequent upon the fulfillment of specified requirements.

Runway. A defined rectangular area on a land aerodrome prepared for the landing and take-off of aircraft.

Runway Visual Range in relation to a runway means the distance in the direction of take-off or landing over which the runway lights or surface markings may be seen from the touchdown zone as calculated by either human observation or instruments in the vicinity of the touchdown zone or where this is not reasonably practicable in the vicinity of the mid-point of the runway; and the distance, if any, communicated to the commander of an aircraft by or on behalf of the person in charge of the aerodrome as being the runway visual range for the time being.

Scheduled Journey means one of a series of journeys which are undertaken between the same two places and which together amount to a systematic service.

Signal Area. An area of an aerodrome used for the display of ground signals.

Skill Test. Demonstration of skill for licence or rating issue including such oral examinations as the examiner may require.

Solo Flight Time. Flight time during which a student pilot is the sole occupant of an aircraft.

Special VFR Flight. A VFR flight cleared by air traffic control to operate within a control zone in meteorological conditions below VMC.

State of Design. The state having jurisdiction over the organisation responsible for the type design.

State of Registry. The State on whose register the aircraft is entered.

Synthetic Flight Trainer. Any one of the following three types of apparatus in which flight conditions are simulated on the ground:

- A Flight Simulator. Which provides an accurate representation of the flight deck of a particular aircraft type to the extent that the mechanical, electrical, electronic etc aircraft control functions; the normal environment of flight crew members, and the performance and flight characteristics of that type of aircraft are realistically simulated
- A Flight Procedures Trainer. Which provides a realistic flight deck environment, and which simulates instrument responses, simple control functions of mechanical, electric, electronic etc aircraft systems, and the performance and flight characteristics of aircraft of a particular class
- A Basic Instrument Flight Trainer. Which is equipped with appropriate instruments, and which simulates the flight deck environment of an aircraft in flight in instrument flight conditions

Take-off Surface. That part of the surface of an aerodrome which the aerodrome authority has declared available for the normal ground or water run of aircraft taking off in a particular direction.

Taxiing. Movement of an aircraft on the surface of an aerodrome under its own power, excluding take-off and landing.

Taxiway. A defined path on a land aerodrome established for the taxiing of an aircraft and intended to provide a link between one part of the aerodrome and another, including:

- Aircraft stand taxi-lane. A portion of an apron designated as a taxiway and intended to provide access to aircraft stands only
- Apron taxiway. A portion of a taxiway system located on an apron and intended to provide a through taxi route across the apron
- Rapid exit taxiway. A taxiway connected to a runway at an acute angle and designed to allow landing aeroplanes to turn off at higher speeds than are achieved on other exit taxiways thereby minimising runway occupancy times

Terminal Control Area (TCA). A control area normally established at the Confluence of ATS routes in the vicinity of one or more major aerodromes.

Total Estimated Elapsed Time. For IFR flights, the estimated time required from take-off to arrive over that designated point, defined by reference to navigation aids, from which it is intended that an instrument approach procedure will be commenced, or, if no navigation aid is associated with the destination aerodrome, to arrive over the destination aerodrome. For VFR flights, the estimated time required from take-off, to arrive over the destination aerodrome.

Track. The projection on the Earth's surface of the path of an aircraft, the direction of which path at any point is usually expressed in degrees from North (true, magnetic or grid).

Traffic Avoidance Service. Advice provided by an air traffic service unit specifying manoeuvres to assist a pilot to avoid a collision.

Traffic Information. Information issued by an air traffic service unit to alert a pilot to other known or observed air traffic which may be in proximity to the position or intended route of flight and to help the pilot avoid a collision.

Transition Altitude. The altitude at or below which the vertical position of an aircraft is controlled by reference to altitudes.

VFR. The symbol used to designate the visual flight rules.

VFR Flight. A flight conducted in accordance with the visual flight rules.

Visibility. The ability, as determined by atmospheric conditions and expressed in units of distance, to see and identify prominent unlighted objects by day and prominent lighted objects by night.

Visual Meteorological Conditions. Meteorological conditions expressed in terms of visibility; distance from cloud, and ceiling equal to or better than specified minima.

VMC. The symbol used to designate visual meteorological conditions.

CHAPTER TWO

INTERNATIONAL AGREEMENTS AND ORGANISATIONS

Contents

THE CHICAGO CONVENTION 21

INTERNATIONAL LAW 22

CUSTOMS AND EXCISE, AND IMMIGRATION 24

INTERNATIONAL OBLIGATIONS OF CONTRACTED STATES 24

DUTIES OF ICAO MEMBER STATES 25

STATUS OF ANNEX COMPONENTS 26

THE INTERNATIONAL CIVIL AVIATION ORGANISATION (ICAO) 26

THE ORGANISATION OF ICAO 27

REGIONAL STRUCTURE OF ICAO 28

REGIONAL STRUCTURE AND OFFICES 29

ICAO PUBLICATIONS 29

OTHER INTERNATIONAL AGREEMENTS 30

THE CONVENTIONS OF TOKYO, THE HAGUE AND MONTREAL 31

THE WARSAW CONVENTION 33

THE ROME CONVENTION 33

IATA 33

ECAC 34

EASA 34

JAA 35

EUROCONTRO L36

GENEVA CONVENTION 36

SUMMARY 37

QUESTIONS 41

ANSWERS 46

THE CHICAGO CONVENTION

2.1 Historical Background. As far as modes of transport is concerned, civil aviation has been the fastest growing and the most technically innovative of any. From the first attempts at powered manned flight to regular space flight we have only just exceeded 100 years of aviation and we have had scheduled commercial air services since 1919. In this day and age of information technology, computerised ticketing systems and computerised flight plans, how did they cope in those early days? It is probably no co-incidence that the first International Conference on Civil Aviation also took place in 1919 at Paris. Since then, the field of our chosen profession has been subjected to far more international legislation and regulation, than any other. The overriding need, which is recognised by all, regardless of political inclination, is for higher and higher safety standards. The degree of international co-operation in this respect is outstanding and shows that where there is a genuine desire to achieve international agreement, it is forthcoming.

2.2 The Second World War. The Second World War had a major effect upon technical development of the aeroplane telescoping a quarter of a century of normal peacetime development into just six years. The strategic use of aeroplanes for the movement of men and materiel to and from theatres of war laid the foundation for the air transport industry we have today. It was foreseen that a vast network of passenger and freight services would be set up but also many problems were foreseen to which solutions had to be found to benefit and support a world subsequently at peace. There was the question of commercial rights - what arrangements would be made for the airlines of one country to fly into and through the territories of another? There were other concerns with regard to the legal and economic conflicts that might come with peace-time flying across national borders such as how to maintain existing air navigation facilities, many of which were located in sparsely populated areas. However, international commercial aviation was considered to be of such importance and a priority issue, that the government of the United States conducted exploratory discussions with other allied (friendly) nations during the early months of 1944. Subsequently, invitations were sent to 55 states to meet in Chicago in November 1944.

2.3 The Meeting at Chicago. For five weeks the delegates of the 52 nations who attended, considered the problems of international civil aviation. The outcome was the Convention on International Civil Aviation, the purpose of which was "... to foster the future development of International Civil Aviation, to help to create and preserve friendship and understanding among peoples of the world, so as to prevent its abuse becoming a threat to the general security thus promoting co-operation between peoples". The 52 states agreed on policy and arrangements so that civil aviation may be developed in a safe and orderly manner and that international air transport services might be established on the basis of equality of opportunity and economically sound operation. A permanent body was subsequently charged with the administration of the principles, the International Civil Aviation Organisation (known throughout the world by the acronym ICAO pronounced eye-kay-oh).

2.4 The "Chicago" Convention. The Chicago Convention, consisting of ninety-six articles (legislative items of agreement), accepts the principle that every state has complete and exclusive sovereignty over the airspace above its territory and provides that no scheduled international air service may operate over or into the territory of a contracting state without that state's previous consent. It established the privileges and restrictions of all contracting states, to provide for the adoption of International Standards and Recommended Practices for:

- Regulating air navigation
- The installation of navigation facilities by contracting states
- The facilitation of air transport by the reduction of customs and immigration formalities

INTERNATIONAL LAW

2.5 Applicable law. There is no world parliament or global legislative body so there is legally no such thing as international law. However, at conventions of states (meetings for the purpose of reaching consensus between states), arrangements are made to regulate activities affecting more than one state through common agreement. The agreements themselves are not legally enforceable as there is no global police force, and all states are entitled to their sovereignty (see definition). What happens is that the national delegation to the convention places before the national parliament (or legislative body) a proposal to make the text of the agreement (and any codicils, appendices, protocols etc...) the law of that state. This process is known as adoption and subsequently, ratification. In this manner what has been agreed inter-nationally, becomes locally enforceable law in the states concerned. An offence committed against such law would be try-able and punishable under national penal legislation in any contracting state anywhere in the world.

2.6 Territorial airspace. The application of national law is only applicable to the territory over which that state has jurisdiction. In aviation, the extent of jurisdiction is limited by the lateral limits of territorial airspace, but unlimited vertically. (An interesting situation regarding satellites and space craft!). Lateral territorial limits have been agreed internationally where such a limit is not coincident with a land boundary. The airspace of Switzerland is easily defined because the country is land-locked. For the UK however, the limit is defined by the limit of territorial waters, which was agreed at the Geneva Convention on the Territorial Sea and Contiguous Zones (1958).

2.7 High Seas. The early international maritime agreements concerned the right to use the "high seas" unhindered. The right of free aviation operation over the high seas was embodied in the Geneva Convention on the High Seas (also of 1958), in which the high seas are defined as '...all the seas outside of territorial seas'. In these (and other) conventions, the established privileges and freedoms of mariners, including those of the flag state (the State in which a vessel is registered and the flag of which the vessel is allowed to fly), were applied to aeroplanes. The rights of non-coastal states to ply the seas under the flag of those countries, requires the co-operation of coastal states to allow free access to the sea. In aviation, similar freedoms are embodied in the Chicago Convention to allow contracting states to fly over the territory of other contracting states for the purpose of international civil aviation operations. At the subsequent UN Convention on the Law of the Sea (1982) the original agreements were updated and reinforced.

2.8 Territory. As defined in international legislation, in aviation terms applies to the airspace existing over the defined limits of a country's territory at ground level.

2.9 Sovereignty. This is the right of a country (or contracting ICAO state) to impose national law to users of the State's territorial airspace.

2.10 Suzerainty (from the French "Suzerain" - Feudal overlord) is the acceptance by a State of all the rules and regulations agreed by common consent at international conventions, even if there is no practical requirement for a state to adopt all of the rules.

COMMERCIAL CONSIDERATIONS

2.11 International Civil Aviation. A matter to which the Chicago Conference attached great importance was the question of exchange of commercial rights in international civil aviation. The states addressed the subject, resulting in contracting states agreeing, bilaterally, to grant each other certain rights regarding the commercial exploitation of civil aviation. These rights are now known as the Freedoms of the Air, and are detailed at {2.10.2 - 2.10.4.} The freedoms give rights to transit the airspace of contracting states to scheduled flights.

2.12 Bilateral Agreements. Due to political and national rivalries, it was not found possible to reach a single agreement satisfactory to all 52 States, therefore two supplementary bilateral agreements were set up which gave each state the opportunity to enter into agreements with other states on a 'one-to-one' basis if considered desirable between those states:

2.13 The International Air Services Transit Agreement permits aircraft of a signatory State to fly over, or land for technical reasons in, the territory of another signatory state;

2.14 The International Air Transport Agreement allows the carriage of traffic between the State of Registration and another signatory state. (Traffic: the carriage of mail, cargo or passengers).

2.15 Definitions. The following definitions are required knowledge.

2.16 Scheduled Flight is a flight, for which agreement has been reached between states (at government level), concerning the schedule. For instance, how many flights would be allowed in any period, what aerodromes could be used, what time of day the flights would be allowed, and what reciprocal arrangements would be required. A state is not obliged to grant permission for an operator to operate a schedule.

2.17 Non-scheduled flights are those to which a schedule is not attached. i.e. one-off flights or charter flights that are not flown on a regular basis. It is an embodiment of the freedoms that a state cannot refuse, on political or economic grounds, to accept a non-scheduled flight.

2.18 Cabotage. Cabotage is defined as the transport of goods or passengers between two points in the same country. In aviation, the term cabotage is used in association with internal (domestic) scheduled commercial air transport. It allows a State the right to restrict internal domestic scheduled (or non-scheduled) air services to aircraft and operators registered in that state. In international aviation, cabotage is permitted and the US is the prime example. No foreign carrier is permitted to operate internally in the US. In the EC, the treaty of Rome demands free access to territory of all EC states and cabotage in aviation within individual EC states is forbidden. This is why Ryanair (an Irish airline) is permitted to operate scheduled services within the UK and other EC states. However, the EC applies cabotage and doesn't permit non-EC states to operate internally within the EC!

CUSTOMS AND EXCISE, AND IMMIGRATION

2.19 Facilitation. Under international law the imposition of customs tariffs and the prohibition of the importation of proscribed items, is allowed. In order to allow contracting states to maintain national Customs and Excise regulations, international flights are required to make the first point of landing in a contracting state at a recognised international airport which provides customs, health and immigration facilities. (In the UK these are known as customs airports). Within the EU the removal of restrictions to free trade now allows flights from one EU state to another to make the first point of landing at a non-customs aerodrome providing certain rules are observed. These rules are explored in the section of this manual concerning Facilitation. Other rules apply to immigration.

INTERNATIONAL OBLIGATIONS OF CONTRACTED STATES

2.20 National and 'International' Law. In becoming an ICAO Contracting State, states agree to observe the International Standards specified by ICAO. From the standards, the international rules and regulations governing civil aviation are drawn. By accepting contracted status, each state accepts the responsibility for enforcement of the rules and regulations within its sovereign territory and airspace (through national law). Article 38 of the Chicago Convention requires each Sovereign State to notify ICAO of any differences between their national regulations and the International Standards adopted. Thus a situation is recognised where national legislation and regulations have precedent over international rules within the territorial airspace of that State. Where flights are conducted over the high seas, the international rules apply without exception. The International (ICAO) Rules of the Air are promulgated (Annex 2) to standardise the procedures for civil aviation specifically for the safety of aircrew and passengers. Other regulations are established to facilitate the smooth and expeditious flow of air traffic by the adoption of Standards and Recommended Practices (SARPS).

2.21 Right to Prosecute Offenders. Where an offence is committed in an aeroplane contrary to the 'international' law, the state, in whose airspace the offence occurs, has the right to try and punish offenders. If the offence occurs over 'the high seas' the state of registration of the aircraft has the right to prosecute the offender(s). Note: The international agreements oblige states to prosecute. If a state doesn't want to (for political reasons) another state may do so. For instance: A bomb is placed on an American aeroplane (contrary to the Montreal Convention and Protocols) by 2 Libyans, in Frankfurt or Rome. The aeroplane explodes over Scotland. Who has the power to prosecute? The order is as follows:

- The UK (under Scottish law) – the offence happened over Scotland
- The United States – the aeroplane was registered in the USA
- The Italians – because the bomb was placed on board in Rome
- The Germans – because the aeroplane made an intermediate stop in Frankfurt
- Any other state, the citizens of which were killed or injured.
- Libya – because the suspects are Libyan

Note: If the UK had not prosecuted, the US most certainly would have.

2.22 Search and Rescue. In accepting contracted State status, each state specifically undertakes to provide procedures and facilities for Search and Rescue (SAR) within the territory of that state. The provision of SAR services in areas of high seas, and areas of undetermined sovereignty, will be established on the basis of Regional Air Navigation (RAN) agreements. The standards governing the provision of SAR services oblige the state to provide at least the minimum service compatible with the type and frequency of the air traffic using the airspace for which the state is responsible, and that service is to be available 24 hours per day. The requirement also imposes upon the state the need to maintain a degree of co-operation with adjacent states and the readiness to assist with SAR operations if requested.

DUTIES OF ICAO MEMBER STATES

2.23 Standards and Recommended Practices (SARPs). The stated aim of the Convention on International Civil Aviation and subsequently the aims of ICAO are to ensure safety, regularity and efficiency of international civil aviation operations. In order to achieve this, the contracting states are required to comply with the Standards and Recommended Practices (SARPs). There are 18 annexes to the Convention, 17 of which are applicable to air navigation. The SARPs are established after consultation with the contracting states and interested international organisations, finalised by the ICAO Air Navigation Commission and submitted to the Council where a two-thirds majority is required for adoption. The SARPs are considered binding on contracting states but if a state finds it impossible to implement the SARPs; it must inform ICAO under the terms of Article 38, of any differences that will exist on the applicability date of the amendment. Such differences will be detailed in the national aeronautical information publication (AIP) and summarised in a supplement to each Annex of the Chicago Convention.

2.24 Customs Duty and Excise. ICAO has addressed taxation in the field of international aviation and member states are required to follow the resolutions and recommendation of the Council in this respect. States are asked to exempt fuel, lubricants, and other technical consumables taken on an aircraft in a state other than the State of registry, providing such supplies are for consumption in flight. Also to reduce or eliminate taxes on international air transport (fares) and to grant, reciprocally to air transport enterprises of other States, exemption from taxation on income and profits. Within the area of customs duty and excise charges, Annex 9 (Facilitation) requires States to apply procedures, which allow expeditious handling of goods and cargo intended for import or which are passing through. The establishment of 'free zones' is encouraged.

2.25 Aircraft Certificates, Registration and Licenses. Annex 7 (Aircraft Nationality and Registration Markings) requires contracting states to apply standard procedures for registration. It includes the format of registration marks and nationality symbols, including the size and where these are to be displayed on aircraft. The annex also calls for the registration of all aircraft and provides a sample of a certificate of registration for use by States. Annex 8 (Airworthiness of Aircraft) requires States to provide a Certificate of Airworthiness, for each registered aircraft, declaring that the aircraft is fit to fly. Under the terms of Annex 1 (Personnel Licensing), SARPs are established requiring each state to apply standardisation in the licensing of personnel involved in international aviation including flight crew members (pilots, flight engineers), air traffic controllers and maintenance technicians. The overriding purpose of such standardisation is to ensure that all involved in air transport operations are licensed to common standards and able to operate throughout the world, thus generating greater trust in aviation on the part of the traveller. A licence issued by the authority in one state is not automatically valid in another State. In this instance, the Annex requires states to establish procedures for the validation of licences issued in other states and defines the method by which such validation shall be annotated.

2.26 Carriage of Dangerous Cargo. More than half the cargo carried by all modes of transport in the world is classified as dangerous. Because of the speed advantages of air transport, a great deal of this cargo is carried by aircraft. In Annex 18 (The Safe Transport of Dangerous Goods by Air), States are required to accept the SARPs associated with the carriage of dangerous goods and to implement the Technical Instructions for the Safe Transport of Dangerous Goods by Air.

2.27 Documentation and Certificates. Other duties of member states include the provisions for the carriage of photographic equipment in aircraft and specification of what documentation is required to be carried. Documentation includes:

- Certificates of Airworthiness
- Flight Crew licences
- Load sheets
- Maintenance documentation

STATUS OF ANNEX COMPONENTS

2.28 Definition. An annex is made up of the following component parts, not all of which are necessarily found in every Annex. They have the status indicated:

2.29 Standards and Recommended Practices (SARPs) are adopted by the Council and are considered binding upon all contracting states unless a state has notified a 'difference' as defined under article 38 of the convention. SARPs defined thus.

2.30 A Standard is any specification for physical characteristics, configuration, materiel, performance, personnel or procedure, the uniform application of which is recognised as necessary for the safety or regularity of international air navigation and to which Contracting States will conform in accordance with the Convention. In the event of impossibility of compliance, notification to the Council is compulsory under article 38 of the Convention.

2.31 A Recommended Practice is any specification for physical characteristics, configuration, materiel, performance, personnel or procedure, the uniform application of which is recognised as desirable in the interest of safety, regularity or efficiency of international air navigation and to which Contracting States will endeavour to conform in accordance with the Convention.

THE INTERNATIONAL CIVIL AVIATION ORGANISATION (ICAO)



2.32 Status. ICAO, created by the Chicago Convention, is an inter-governmental organisation, which has become a specialised agency in relationship with the United Nations. The headquarters of ICAO is in Montreal and it provides the machinery to achieve standardisation and agreement between Contracting States of all technical, economic and legal aspects of international civil aviation.

2.33 ICAO Aims and Objectives. The aims and objectives of ICAO are to develop the principles and techniques of international civil air navigation and to foster the planning and development of international air transport so as to:

- Ensure the safe and orderly growth of international civil aviation throughout the world.
- Encourage arts of aircraft design and operation.
- Encourage the development of airways, airports and air navigation facilities.
- Meet the need for safe, regular, efficient and economical air transport.
- Prevent waste caused by unreasonable competition.
- Ensure the rights of Contracting States are fully respected.
- Avoid discrimination between Contracting States.
- Promote the safety of flight in international aviation.
- Generally promote all aspect of international civil aeronautics.

THE ORGANISATION OF ICAO



2.34 The Assembly. The sovereign body of ICAO is the Assembly, which meets at least once every three years and is convened by the Council. Each Contracting State is entitled to one vote and decisions of the Assembly are by majority vote of the Contracting States.

2.35 The Council. The Council of ICAO is a permanent body responsible to the Assembly and is composed of 33 Contracting States elected by the Assembly for a three-year term. The Council is the governing body of ICAO.

2.36 The Commissions and Committees of ICAO are composed of members, appointed by the Council, from nominations of contracting states or elected from amongst Council members. They are:

- The Air Navigation Commission
- The Air Transport Committee
- The Legal Committee
- The Committee on Joint Support of Air Navigation Services
- The Personnel Committee
- The Finance Committee
- The Committee on Unlawful Interference

2.37 Air Navigation Commission. This is the body that proposes, formulates and finalises the SARPs and presents them for adoption by the Council.

2.38 The ICAO Secretariat is divided into sections, each corresponding to a Committee, and supplies technical and administrative aid to the Council. It is headed by a Secretary- General, appointed by the Council, and is divided into five main divisions:

- Air Navigation Bureau
- Air Transport Bureau
- Technical Assistance Bureau
- Legal Bureau
- Bureau of Administration and Services

REGIONAL STRUCTURE OF ICAO

2.39 Regions and Offices. ICAO maintains seven regional offices: Bangkok, Cairo, Dakar, Lima, Mexico City, Nairobi and Paris. Each regional office is accredited to a group of Contracting States (making up nine recognised geographic regions) and the main function of regional offices is maintaining, encouraging, assisting, expediting and following-up the implementation of air navigation plans. The nine geographic regions are:

AFI - Africa - Indian Ocean; NAM - North America; ASIA - Asia; CAR - Caribbean;
NAT - North Atlantic; EUR - Europe; PAC - Pacific; MID - Middle East; SAM - South America

2.40 The Need for a Regional Structure. In dealing with international civil aviation, there are many subjects that ICAO considers on a regional basis as well as on a worldwide scale. In order to facilitate:

- The planning of facilities and services
- The formulation of supplementary procedures to support increases in traffic density
- New air routes
- The introduction of new types of aircraft

REGIONAL STRUCTURE AND OFFICES

2.41 Regional Air Navigation (RAN) meetings are held periodically to consider the requirements of air operations within specified geographic areas. The plan, which emerges from a regional meeting, is so designed that, when the states concerned implement it, it will lead to an integrated, efficient system for the entire region and contribute to the global system. In addition to the duties detailed above, the regional offices are responsible for keeping the regional plans up to date.

2.42 Financial Assistance. Through the regional offices, financial assistance is provided to assist states in specific circumstances. The provision of air traffic control, navigation aids and meteorological services in Greenland and Iceland are examples of this specific aid, where due to the intense air traffic using the airspace of those states such expenditure is disproportionate to the gross national product of those states.

ICAO PUBLICATIONS

2.43 The Annexes. One of the major duties of the ICAO Council is to adopt International Standards and Recommended Practices (SARPS) and incorporate these as annexes to the Convention on International Civil Aviation. There are now 18 annexes to the 1944 convention which are constantly under review to ensure that the content realistically meets the requirements of civil aviation now. You are required to be able to identify the annex and content. The 18 annexes are:

Annex 1.	Personnel Licensing
Annex 2.	Rules of the Air
Annex 3.	Meteorological Services for International Air Navigation
Annex 4.	Aeronautical Charts
Annex 5.	Units of Measurement to be used in Air and Ground Operations
Annex 6.	Operation of Aircraft
Annex 7.	Aircraft Nationality and Registration Marks
Annex 8.	Airworthiness of Aircraft
Annex 9.	Facilitation
Annex 10.	Aeronautical Telecommunications
Annex 11.	Air Traffic Services
Annex 12.	Search and Rescue
Annex 13.	Aircraft Accident Investigations
Annex 14.	Aerodromes
Annex 15.	Aeronautical Information Services
Annex 16.	Environmental Protection
Annex 17.	Security - Safeguarding International Civil Aviation against Acts of Unlawful Interference
Annex 18.	The Safe Transport of Dangerous Goods by Air

2.44 PANS. Where the content of the SARPS is somewhat technical and requires further explanation or discussion, Procedures for Air Navigation Services (PANS) are published by ICAO. PANS are approved by the Council, unlike SARPS which are adopted by the Council.

2.45 PANS OPS (Doc 8168) Procedures for Air Navigation Services - Aircraft Operations. This publication (in two parts) describes the Operational Procedures recommended for the guidance of flight operations personnel (Vol. 1) and procedures for specialists in the essential areas of obstacle clearance requirements for the production of instrument flight charts (Vol. 2).

2.46 PANS ATM (Doc 4444) Procedures for Air Navigation – Air Traffic Management. This document specifies the requirements for the establishment of an Air Traffic Control Service.

2.47 Regional Supplementary Procedures (Doc 7030/4). Where navigational procedures, which differ from the worldwide procedures, are deemed necessary for a specific geographic region by the appropriate Regional Air Navigation Meeting, such procedures are recorded in the relevant region section of Doc 7030/4, and are known as Regional Supplementary Procedures (SUPPS). As in the case of PANS, SUPPS are approved by the Council, but only for regional use.

OTHER INTERNATIONAL AGREEMENTS

2.48 The International Air Services Transit Agreement and the International Air Transport Agreement. The Chicago Convention attached great importance to the question of the exchange of commercial rights in international civil aviation. It was not found possible to reach an agreement satisfactory to all the original 52 states, but the conference set up two supplementary agreements - the International Air Services Transit Agreement, and the International Air Transport Agreement. The first agreement made provision for aircraft of any participating state to fly over, or to land for technical reasons in, the territory of any other participating state. The second provided, among other things, for the carriage of traffic (passengers, mail and cargo. between the State of Registration of the aircraft and any other signatory state.

2.49 The Freedoms of the Air. The International Air Services Transit Agreement established two technical freedoms of the air (known as the first and second freedoms. In this context the word 'freedom' refers to the privilege conferred by virtue of signatory status to a bilateral agreement. Because the two agreements require bilateral understandings between the parties, ICAO has produced the 'Chicago Standard Form for Bilateral Agreement for Regular Air Transport' based on the definitions for the Freedoms of the Air, as defined in the International Air Services Transit and the International Air Transport Agreements. For general aviation and non-scheduled commercial operations, the filing of an international flight plan is the method by which a flight gives notification to exercise the privileges of the appropriate freedoms.

2.50 The Technical Freedoms: These comprise the first two freedoms and were established through the International Air Services Transit Agreement:

2.51 First Freedom: The privilege to fly across the territory of another participating state without landing.

2.52 Second Freedom: The privilege to land in another participating state for non-traffic purposes (i.e. refuelling or repair. but not for uplift or discharge of traffic passengers, cargo or mail).

2.53 The Commercial Freedoms. The International Air Transport Agreement established three further freedoms. These are defined as commercial and whilst still bilateral, are subject to inter-government negotiation.

2.54 Third Freedom: The privilege to put down in another state (e.g. the USA) traffic taken on in the state of registration (e.g. the UK).

2.55 Fourth Freedom: The privilege to take on in another state (e.g. the USA), traffic destined for the state of airline registration (e.g. the UK).

2.56 Fifth Freedom: The privilege for an airline registered in one state (e.g. the UK) and en-route to or from that state, to take on traffic in a second state (e.g. Greece) and put them down in a third state (e.g. Italy).

2.57 Modern Freedoms. Due to the process of growth in air transport and the evolution of airlines operating on a global basis, further commercial freedoms have evolved. However, these are not covered by the LOs for Air Law.

2.58 Bermuda Agreement. The first bilateral Air Transport Agreement (ATA) was signed at Bermuda in 1946 between the UK government and the US government and set an example for other states to follow. Currently there are some 3000 ATAs in force globally.

THE CONVENTIONS OF TOKYO, THE HAGUE AND MONTREAL

2.59 The Tokyo Convention of 1963. This convention provides that the State of Registration of an aircraft is competent to exercise jurisdiction over offences and acts committed on board. Its object is to ensure that offences, wherever committed should not go unpunished. As certain acts committed on board an aircraft may jeopardise the safety of the aircraft or persons and property on board or may prejudice good order and discipline on board, the aircraft commander and others are empowered to prevent such acts being committed and to deliver the person concerned to the appropriate authority. In the case of an anticipated or actual unlawful or forcible seizure of an aircraft in flight by a person on board, the States party to the Convention are obliged to take all appropriate measures to restore and preserve control of the aircraft to its lawful commander.

2.60 The Hague Convention of 1970. After a spate of politically motivated terrorist hijackings of aircraft in the 1960's, the international community, under the auspices of ICAO, resolved to work together to prevent or deter (suppress) such acts. Otherwise known as the Convention for the Suppression of Unlawful Seizure of Aircraft, signed at The Hague in December 1970, the convention defines the act of unlawful seizure of aircraft (hijacking), and lists which contracting states have undertaken to make such offences punishable by severe penalties. The convention contains detailed provisions on the establishment of jurisdiction by states over the offence; on the taking of the offender into custody; and on the prosecution or extradition of the offender. This convention came into effect on 14 October 1971.

2.61 The Montreal Convention of 1971. This Convention is correctly titled the Convention for the Suppression of Unlawful Acts against the Safety of Civil Aviation. It makes it an offence to attempt any of the unlawful acts specified or to be an accomplice to such acts. The contracting states have undertaken to make these offences punishable by severe penalties. The convention contains similar detailed provisions regarding jurisdiction, custody, prosecution and extradition of the alleged offender as the Hague Convention of 1970. This convention came into force on 26 January 1973. It is mainly concerned with acts other than those pertaining to the unlawful seizure i.e.:

- Acts of violence on board which endanger people and property and the safety of the aeroplane
- The destruction of an aircraft in service or causing damage which renders it incapable of flight or which is likely to endanger its safety in flight
- Placing in an aircraft any device likely to destroy, damage or render unfit for flight any aircraft

- Destroying or damaging any air navigation facility or interference with its correct operation
- The communication of information known to be false which endangers the safety of an aeroplane in flight

2.62 The Protocol Supplementary to the Montreal Convention of 1971. This protocol was adopted by a conference, which met at Montreal in 1988. It extends the definition of offence given in the 1971 Convention to include specified acts of violence at airports serving international civil aviation. Such acts include:

- The intentional and unlawful use of any device, substance or weapon in performing an act of violence against a person at an airport serving international civil aviation, which causes or is likely to cause serious injury or death
- The intentional and unlawful use of any device, substance or weapon to:
 - Destroy or seriously damage the facilities of an airport
 - Destroy or seriously damage aircraft not in service at the airport
 - Disrupt the services at an airport

2.63 Enforcement. Contracting States have undertaken to make these offences punishable by severe penalties. The protocol also contains provisions on jurisdiction.

2.64 Annex 17. The measures taken by ICAO have resulted in the adoption of the SARPS detailed in Annex 17 - Security. The provisions of the SARPS are applicable to all Contracting States. The Annex requires all contracting States to:

- Establish national civil aviation security programmes
- To designate an authority responsible for security
- To keep the level of threat under constant review
- To co-ordinate activities with other relevant national agencies and liaise with the corresponding authority in other States

2.65 Programmes and plans. In order to make such activities workable and efficient, States are also required to set up training programmes, establish airport security committees and to have contingency plans drawn up.

2.66 International co-operation. As an on-going commitment to security, each State is required to co-operate with other States in research and development of security systems and equipment which will better satisfy civil aviation security objectives.

2.67 The Authority of the Commander. The aircraft commander may order or authorise the assistance of other crew members and may request and authorise, but not order, the assistance of passengers to restrain any person he is required to restrain. The aircraft commander may, when he has reasonable ground to believe that a person has committed, or is about to commit, an act which may or does jeopardize the safety of the aircraft or persons or property on board or which jeopardize good order and discipline on board, impose reasonable measures, which may include restraint, necessary:

- To protect the safety of the aircraft, or of persons or property on board
- To maintain good order and discipline on board
- To enable him to deliver such a person to competent authorities or to disembark him in accordance with provision of the Convention

THE WARSAW CONVENTION

2.68 Liability of the Carrier. The Warsaw Convention of 1929 concerned itself with responsibilities and liabilities of the Carrier and the Agents of aircraft together with matters of compensation for loss of life or injury to passengers; delays and loss of baggage. This limited the liability, except in cases of gross negligence, to roughly the equivalent of US\$10,000 in International Bank Special Drawing Rights (SDRs). In 1955 an amendment to the Convention was adopted by a diplomatic conference at The Hague (known as The Hague Protocol) which doubled the existing limits of liability and the present limit is a maximum amount of US\$100,000 per person. By agreeing to the terms of the Warsaw agreement, an airline agrees to pay compensation without further process of law however, the amounts payable are nowadays relatively small in litigation circumstances. Some airlines, state that they will not be bound by the Warsaw agreement and will pay higher amounts of compensation if awarded by a Court.

2.69 Issue of a Ticket. The issuing of a passenger ticket, luggage ticket or cargo consignment note, forms a contract between the carrier and the person receiving the ticket/note. The contract is defined by the Warsaw Convention including the previously mentioned exclusion or limitation of liabilities. If a carrier accepts a passenger, luggage or cargo on board an aeroplane without a ticket/note, then the carrier is liable for any loss which is occasioned without the protection of the limits set by the Warsaw Convention. The loss, irregularity or absence of a ticket/note does not affect the existence or the validity of the contract. If applicable, the Operator is required to draw the passenger's attention to the Warsaw Convention limits of liability where 'electronic' tickets are issued.

THE ROME CONVENTION

2.70 The Rome Convention of 1952 dealt with damage caused by foreign aircraft to third parties on the ground. It permits a claimant to pursue a claim against a foreign operator through the Court in the state of residence. Any resulting judgement would then be enforceable in the state of the Operator.

IATA



2.71 The International Air Transport Association (IATA) is the air transport industry global trade organisation. Over 60 years, IATA has developed the commercial standards that have built a global industry. Today, IATA's mission is to represent, lead and serve the airline industry. Its members comprise some 260 airlines - the world's leading passenger and cargo airlines among them - representing 94 percent of international scheduled air traffic. IATA seeks to improve understanding of the industry among decision makers and increase awareness of the benefits that aviation brings to national and global

economies. It fights for the interests of airlines across the globe, challenging unreasonable rules and charges, holding regulators and governments to account, and striving for sensible regulation.

ECAC



2.72 European Civil Aviation Conference (ECAC) is the driving force for a common civil aviation policy in Europe. It was set up under the auspices of the Council for Europe and ICAO. Membership now extends from Iceland to Turkey (all the European Commission countries are members of ECAC). ECAC is an inter-governmental organisation founded in 1955 from the Conference on the Co-ordination of Air Transport in Europe (CATE), with the aim of promoting the continued development of a safe, efficient and sustainable European air transport system. ECAC seeks to:

- Harmonise civil aviation policies and practices amongst its member states
- Promote understanding on policy matters between member states and other parts of the world

2.73 Aims. Within Europe, because of its established position, ECAC is the only forum for consideration of major civil aviation topics relevant to all European states. The strength of ECAC is derived from:

- Membership across Europe
- Active co-operation with institutions of the EU (including the EC and the European Parliament)
- Close liaison with ICAO
- Established relationships with organisations representing all parts of the air transport industry including consumer and airline interests

EASA



2.74 European Aviation Safety Agency (EASA). The European Aviation Safety Agency is the centrepiece of the European Union's strategy for aviation safety. Its mission is to promote the highest common standards of safety and environmental protection in civil aviation. While national authorities continue to carry out the majority of operational tasks - such as certification of individual aircraft or licensing of pilots - the Agency ensures common safety and environmental standards at the European level. The agency's current responsibilities include:

- Rulemaking: drafting safety legislation and providing technical advice to the European institutions and the member states
- Inspections, training and standardisation programmes to ensure uniform implementation of European aviation safety legislation in all member states
- Safety and environmental type-certification of aircraft, engines and parts
- Approval and oversight of aircraft design organisations world-wide and of production and maintenance organisations outside the EU
- Data collection, analysis and research to improve aviation safety

JAA



2.75 The Joint Aviation Authorities. The Joint Aviation Authorities (JAA) are an associated body of ECAC representing the civil aviation regulatory authorities of a number of European States who have agreed to co-operate in developing and implementing common safety regulatory standards and procedures. This co-operation is intended to provide high and consistent standards of safety and a 'level playing field' for competition in Europe. The JAA Membership is based on signing the "JAA Arrangements" document originally signed by the then current member states in Cyprus in 1990.

2.76 Objectives. The JAA objectives and functions may be summarised as follows:

- To ensure, through co-operation, common high levels of aviation safety within Member States
- Through the application of uniform safety standards, to contribute to fair and equal competition within Member States
- To aim for cost-effective safety and minimum regulatory burden so as to contribute to European industry's international competitiveness

2.77 JAA Organisation. The JAA is controlled by a Committee, which works under the authority of the Plenary Conference of ECAC and reports to the JAA Board of Directors General. The Board is responsible for review of general policy and long term objectives of the JAA. The JAA Committee is composed of one member from each Authority and is responsible for the administrative and technical implementation of the Arrangement. The Committee and the Board are supported by a Secretariat.

2.78 JAA Documentation. The Authorities agreed to co-operate to produce common comprehensive and detailed requirements and where necessary acceptable means of compliance with and interpretations of them (the Joint Aviation Requirements - JARs). JARs encompass both technical and administrative functions. In developing JARs, the JAA takes into account the duties and obligations under the Chicago Convention; consults the parties to whom the requirements apply and takes into account other aviation codes so as to facilitate exchange of products, services or persons or reliance on organisations, between the JAA countries and other countries in the world.

EUROCONTROL



2.79 History and Role. Eurocontrol was founded in 1960 with the objective of providing common ATC services in the upper airspace of Member States and strengthening co-operation between Member States in matters of air navigation. Eurocontrol was established under the International Convention Relating to Co-operation for the Safety of Air Navigation signed at Brussels on 13 December 1960. Initially, six countries signed the agreement: Germany (FDR); Belgium; France; United Kingdom; Luxembourg and the Netherlands. In 1999 there were 26 member states and the organisation was greatly reformed through the revised Eurocontrol Convention of June 1997. The Eurocontrol ATCC is at Maastricht, Holland. The role of Eurocontrol is now much wider than originally envisaged. The limit of operations, to just the upper airspace, was abandoned in 1986 and Eurocontrol now has a much wider remit, placed on the

Organisation by ECAC, most notably in the area of Air Traffic Flow Management (ATFM) which led to the establishment of the Eurocontrol Central Flow Management Unit (CFMU) in 1988. Eurocontrol has a training centre in Luxembourg and an experimental research centre at Brétigny, France, with a new ATCC in Vienna (CEATS).

GENEVA CONVENTION

2.80 The Convention on International Recognition of Rights in Aircraft (Geneva 1947) established the right of the seller of an aircraft to secure any lending (mortgage) granted to the buyer, by a mortgage against the aircraft. Specifically the convention:

- Outlawed double registration
- Made it a requirement that the registering authority address appeared on the certificate of registration
- Contained requirements regarding salvage of aircraft
- Stipulated that an aircraft could not be transferred from one register to another unless all interested parties had been informed
- Stipulated that the articles of the Convention would not prevent a State imposing its laws relating to immigration, customs or air navigation

SUMMARY

RELEVANT INTERNATIONAL CONVENTIONS AND AGREEMENTS

DATE	PLACE	TITLE	CONTENT
October 1919	Paris	Convention Relating to the Regulation of Air Navigation	Sovereignty over airspace. Standards for airworthiness. Certificates of competency for crews. Definition of 'aircraft'.
October 1929	Warsaw	Convention for the Unification of Certain Rules Relating to International Carriage by Air	Carrier's liability for damage caused to passengers, baggage and goods. Damage caused by delay.
May 1933	Rome	Convention for the Unification of Certain Rules Relating to Damage Caused by Aircraft to Third Parties on the Surface	Recognised the liability of carrier for damage caused on the ground. Led to the Brussels Insurance Protocol of 1938 Replaced by the Rome Convention of 1952 (drafted by ICAO)
May 1933	Rome	Convention for the Unification of Certain Rules Relating to Precautionary Arrest of Aircraft	Specified which aircraft can be arrested or 'attached'. Excludes government aircraft (incl postal transport), aircraft in service on public transport (and back-up aircraft), aircraft apportioned for the carriage of persons or goods for reward.
September 1938	Brussels	Protocol Supplementing the Convention for the Unification of Certain Rules Relating to Damage Caused by Aircraft to Third Parties on the Surface	Obligation of carrier to arrange third party insurance. This is what eventually killed off Pan Am!
December 1944	Chicago	Convention on International Civil Aviation	Regulation of Civil Aviation. Led to the creation of ICAO. 18 Annexes to the Chicago Convention
December 1944	Chicago	International Air Services Transit Agreement	The two technical freedoms of the air
December 1944	Chicago	International Air Transport Agreement	The three commercial freedoms of the Air (Known as the 5 freedoms agreement ; 2 + 3 = 5) Note: The other freedoms 6, 7 and 8 are really no more than minor variations of these 5.

June 1948	Geneva	Convention on the International Recognition of Rights in Aircraft	To protect the rights of the seller where aircraft are bought on HP, mortgage or lease.
October 1952	Rome	Convention on Damage by Foreign Aircraft to Third Parties on the Surface	Replaced the 1933 Convention. Poor ratification. (USA, UK, Canada, Germany and many other major players) refused to ratify because compensation too low; National Law more powerful. El Al crash in Holland, neither states contracting.
September 1955	The Hague	Protocol to Amend the Convention for the Unification of Certain Rules Relating to International Carriage by Air	<ul style="list-style-type: none"> a. Removed exemptions for all except military aircraft b. Raised compensation limit to 250 000 gold francs c. Simplified the requirements for tickets and baggage checks d. Made carrier liable for 'pilot error'
April 1956	Paris	Multilateral Agreement on Commercial Rights of Non-Scheduled Air Services in Europe	An ECAC convention. Covers international flights within Europe of a non scheduled nature: Humanitarian and emergency; taxi class services (seating limited to 6 and not to be re-sold); hiring by a single person (or company); single flights.
April 1960	Paris	Multilateral Agreement relating to Certificates of Airworthiness for Imported Aircraft	ECAC agreement. Allows states to render valid an existing C of A or issue a new one.
September 1961	Guadalajara	Convention Supplementary to the Convention for the Unification of Certain Rules Relating to International Carriage by Air Performed by a Person Other than the Contracting Carrier	Covers charter services and 'wet-leasing'. Defines who the contracting carrier and the actual carrier is in a charter or wet-lease situation. Defines the liability of the carrier(s).

September 1963	Tokyo	Convention on Offences and Certain Other Acts Committed on Board Aircraft	Determines who's penal law is applicable Defines the rights and obligations of the aircraft Commander Defines the rights and obligations of the authorities of the state in which the aircraft lands after Defines unlawful seizure of aircraft
December 1970	The Hague	Convention for the Suppression of Unlawful Seizure of Aircraft	Applicable to domestic and international flights. Defines 'in flight'. Allocates jurisdiction after offence committed: a. State of Registration b. State of landing if offender still on board c. State of Operator d. State in which offender is apprehended if that state does not wish to extradite
March 1971	Guatemala City	Protocol to Amend the Convention for the Unification of Certain Rules Relating to International Carriage by Air	Makes the carrier absolutely liable. Replaces 'fault' liability with 'risk' liability i.e. in the case of death or injury caused by sabotage or hi-jacking. Limits liability to \$100 000 for passengers and baggage including negligence. Exceptions: a. self inflicted or wilful damage by the claimant b. death or injury resulting from ill health of passenger
September 1971	Montreal	Convention for the Suppression of Unlawful Acts Against the Safety of Civil Aviation	Deals with a person who: a. acts violently on board an aircraft b. destroys or damages an aircraft in service c. places an EOD or similar on board an aircraft d. destroys or damages a nav aid or interferes with operation e. passes false information thus endangering an aircraft
September 1971	Montreal	Supplementary to the Convention for the Suppression of Unlawful Acts Against the Safety of Civil Aviation	Deals with offences committed at an airport serving international aviation

September 1975	Montreal	Additional Protocols (1 - 4) to Amend the Convention for the Unification of Certain Rules Relating to International Carriage by Air	Allows payment to be made in IMF Special Drawing Rights (SDR) Replaces limits in Hague Protocol with SDRs Replaces limits in Guatemala Protocol with SDRs Changes liability regarding goods - applies SDRs
September 1978	Montreal	Protocol to Amend the Convention on Damage by Foreign Aircraft to Third Parties on the Surface	Extended Rome 1952 to include damage caused by an aircraft registered, the state of Operator is, or the operator lives or his place of residence is - in another contracting state.
December 1982	Montego Bay	UN Convention of the High Seas	Air Piracy an offence Hot pursuit permitted Territorial waters extended to 12 nm 200 nm economic zone respected - freedom to overfly Right to transit straits without permission no longer allowed - freedom to transit straits under 1st freedom reinforced Established the authority of the Hamburg Court regarding disputes of overflying rights in territorial waters, contiguous zones, etc..
September 1990	Cyprus	The Convention of Cyprus	Established the JAA
October 1995	Kuala Lumpur	IATA Intercarrier Agreement on Passenger Liability	Agreement by IATA members to waive limitations of liability and recoverable damages established by the Warsaw Convention. Damages to be awarded by reference to the law of domicile of the passenger.

QUESTIONS

1. What does Cabotage refer to?
 - a. Domestic air services within a state.
 - b. An international air carrier.
 - c. A flight above territorial waters.
 - d. Crop spraying.

2. The Convention signed by the states relating to damage caused by foreign aircraft to persons and property on the ground is:
 - a. the Tokyo convention.
 - b. the Rome convention.
 - c. the Warsaw convention.
 - d. the Paris convention.

3. The Convention on offences and other acts committed on board an aeroplane is:
 - a. the Tokyo convention.
 - b. the Paris convention.
 - c. the Rome convention.
 - d. the Chicago convention.

4. Which of the following is an obligation of being an ICAO contracting state?
 - a. ICAO must be informed about all new flight crew licences and any suspended validity of such licences.
 - b. ICAO must be informed about differences from the standards detailed in any of the annexes to the Chicago Convention.
 - c. ICAO must approve the pricing of tickets on international airline connections.
 - d. ICAO must be informed about changes to national regulations.

5. Which of the following annexes to the Chicago Convention contains the minimum specifications for the construction of aerodromes?
 - a. Annex 6.
 - b. Annex 11.
 - c. Annex 10.
 - d. Annex 14.

6. The ICAO annex containing the standards and recommended practices for Personnel Licensing is:
 - a. Annex 1.
 - b. Annex 2.
 - c. Annex 11.
 - d. Annex 12.

7. The aircraft commander may, when he/she has reasonable grounds to believe that a person has committed or is about to commit an offence against penal law on board the aircraft:
 - a. ask the person to disembark.
 - b. ask the crew to assist in restraining the person.
 - c. order the passengers to assist the crew in restraining the person.
 - d. deliver the person to the competent authority.
8. The international convention concerning the responsibilities of international air carriers (operators), for the carriage of passengers, baggage and freight is the:
 - a. Tokyo convention.
 - b. Hague convention.
 - c. Montreal convention.
 - d. Warsaw convention.
9. The Rome convention and its later amendments deals with:
 - a. offences and other acts committed on board an aeroplane.
 - b. damage caused by foreign aircraft to third parties on the ground.
 - c. regulation of the transportation of dangerous goods.
 - d. damage caused by any aircraft to third parties on the ground.
10. The Warsaw convention and its later amendments deals with:
 - a. regulation of the transportation of dangerous goods.
 - b. operators licence for international scheduled operations.
 - c. security systems at airports.
 - d. limitation of the Operator's liability concerning passengers and goods transported.
11. The objectives of ICAO were defined by:
 - a. the Geneva Convention of 1936.
 - b. the Chicago Convention of 1944.
 - c. the Warsaw Convention of 1929.
 - d. the Geneva Convention of 1948.
12. The annex to the Chicago convention which deals with the entry and departure of cargo and other articles on international flights is:
 - a. Annex 15.
 - b. Annex 16.
 - c. Annex 9.
 - d. Annex 8.
13. Which freedom of the air is applicable to a flight which wishes to land in a foreign state for technical reasons?
 - a. 1st freedom.
 - b. 3rd freedom.
 - c. 4th freedom.
 - d. 2nd freedom.

14. ICAO establishes:
 - a. aeronautical standards adopted by all states.
 - b. proposals for aeronautical regulations in the form of 18 annexes.
 - c. standards and recommended practices applied without exception by all states which are signatory to the Chicago Convention of 1944.
 - d. standards and recommended practices for contracting states.

 15. The first freedom of the air is:
 - a. The right to board passengers from the state where the aircraft is registered and fly to any other state.
 - b. The right to over fly without landing.
 - c. The right to land for a technical stop.
 - d. The right to operate a commercial flight with passengers on board between two states.

 16. The Convention which deals with offences against penal law is:
 - a. the convention of Rome.
 - b. the convention of Madrid.
 - c. the convention of Tokyo.
 - d. the convention of Warsaw.

 17. One of the main objectives of ICAO is to:
 - a. develop principles and techniques for international aviation.
 - b. approve the ticket prices set by international airlines.
 - c. approve new airlines operating turbine engine powered aircraft.
 - d. approve new international airlines.

 18. Which international convention established ICAO?
 - a. Chicago.
 - b. The Hague.
 - c. Warsaw.
 - d. Montreal.

 19. The standards contained in the annexes to the Chicago convention are to be considered:
 - a. binding upon all airlines operating international routes.
 - b. binding for contracting states that have not notified ICAO about national differences.
 - c. advice and guidance for the aviation legislation within contracting states.
 - d. binding for all contracting states.

 20. Which body of ICAO finalises the SARPS to be submitted for adoption?
 - a. The Council.
 - b. The Regional Air Navigation Committee.
 - c. The Air Navigation Commission.
 - d. The Assembly.
-

21. The second freedom of the air is the:
- a. right to cabotage traffic.
 - b. right to operate a commercial passenger flight with passengers on board between two states.
 - c. right to land in a foreign for a technical stop.
 - d. right to over fly a foreign state without landing.
22. Which annex contains information concerning Air Traffic Services?
- a. Annex 11.
 - b. Annex 10.
 - c. Annex 14.
 - d. Annex 15.

ANSWERS

Question	Answer	Reference
1.	A	2.18
2.	B	2.70
3.	A	2.59
4.	B	2.23
5.	D	2.43
6.	A	2.43
7.	D	2.59
8.	D	2.68
9.	B	2.70
10.	D	2.68
11.	B	2.32 / 2.33
12.	C	2.43
13.	D	2.50
14.	D	2.40
15.	B	2.50
16.	C	2.59
17.	A	2.33
18.	A	2.32
19.	B	2.29
20.	C	2.37
21.	C	2.52
22.	A	2.43

CHAPTER THREE
AIRWORTHINESS OF AIRCRAFT

Contents

INTRODUCTION	49
AIRWORTHINESS	49
QUESTIONS	51
ANSWERS	52

INTRODUCTION

3.1 Background. The Chicago Convention placed great emphasis on safety, and one particular 'area of interest' was in the airworthiness of aeroplanes. In order to ensure that an aeroplane was safe to use it was agreed that all aeroplanes would have a certificate that stated that the aircraft was airworthy when manufactured, and that through the continued validation of that certificate, the continuing airworthiness of the aircraft would be ensured. During the design and building stage of the life of a type of aeroplane, rigorous rules and regulations are applied to the manufacturing processes and the flight testing process, to ensure that the aircraft does what it is intended to do. Once the testing procedures have been successfully completed, the State of Manufacture (the USA in the case of Boeing aircraft and France in the case of Airbus) issues a Certificate of Airworthiness to the type and this is then applicable to all subsequent production models (issued to the individual aircraft by the State of Registry after a short 'compliance' air test). The initial certificate would also be applicable to all subsequent marks or upgrades of the type, within reason. The FAA and UK CAA decided that the 747-400 was not the same aeroplane as the original 747, and required re-certification. An expensive process for Boeing! For the initial flight testing, the prototype is permitted to fly under a Permit to Fly issued by the State of Manufacture.

3.2 Standards. The Airworthiness standards of Annex 8 of the Chicago Convention are related to the standards of Annex 6, part 1, which deals with aeroplane performance operating limitations. An element of the safety of an operation is the intrinsic safety of the aircraft. That is, its airworthiness. The airworthiness of an aircraft is not fully defined by the application of the airworthiness Standards of Annex 8, but also requires the application of the Standards of Annex 6 that are complimentary. In other words, Annex 8 deals with airworthiness from the engineering point of view, whereas Annex 6 deals with the safety standards necessary for any operation. The standards apply to both performance and flying qualities.

3.3 Applicability. The Standards of Airworthiness, detailed in Annex 8 Part 3 are applicable to aeroplanes with certificated maximum take-off mass greater than 5 700kg, intended for the carriage of passengers, cargo or mail in international air navigation. Unless specifically exempted, the standards apply to the complete aeroplane including power-units, systems and equipment. For the standards to be applicable; the aircraft must have at least two engines.

AIRWORTHINESS

3.4 Certificate of Airworthiness. A Certificate of Airworthiness (CofA) is issued by the State of Registration when satisfactory evidence is provided that the aeroplane complies with the appropriate airworthiness requirements. ICAO has specified a standard form of C of A which is to include the nationality and registration marks, manufacturer and designation of the aircraft (i.e. Boeing 747-400), aircraft serial number (i.e. the airframe number like a car chassis number).

3.5 Continuing Airworthiness. The State of Registry is responsible for determining if an aircraft continues to be airworthy. The state is required to maintain a system for recording faults, malfunctions, defects or other occurrences which might affect the airworthiness of aircraft with maximum take off mass greater than 5700 Kg.

3.6 Structural Integrity/Corrosion Control. The State of Design is required to ensure that a structural integrity programme exists to ensure the airworthiness of aircraft with a maximum take off mass greater than 5700Kg. The programme is to include information concerning corrosion control.

3.7 Validity of C of A. The C of A will be renewed or will remain valid provided that the continued airworthiness of the aircraft has been determined by a periodic inspection. The period between the inspections is to be established by the state. Where an aircraft is damaged, it is the responsibility of the State of Registry to judge whether the damage is of such a nature that the aircraft is no longer airworthy. Where a damaged aircraft is repaired, the State of Registry is to specify the necessary repairs and to determine that such repairs have been properly carried out before re-issuing a C of A.

3.8 Aircraft Limitations and Information. Each aircraft is required to have a flight manual (or other means) in which the approved limitations are defined and additional information is contained necessary for the safe operation of the aeroplane. Where the determined limiting speeds are specified as a Mach number, the aircraft is to be fitted with a Mach meter.

QUESTIONS

1. The State of Design is to ensure that a continuing structural integrity programme, including information concerning corrosion control, is maintained in respect of aeroplanes:
 - a. with maximum certificated take-off mass less than 5700kg.
 - b. with maximum certificated take-off mass greater than 5700kg.
 - c. with maximum certificated take-off mass equal to 5700kg.
 - d. with maximum certificated take-off mass not more than 5700kg.

2. The continuing validity of a Certificate of Airworthiness of an aircraft is subject to the laws of:
 - a. the State of Registration.
 - b. the State of Registration or the State of the Operator.
 - c. the State of Operator.
 - d. the State of Registration and the State of Design.

ANSWERS

Question	Answer	Reference
1.	B	3.6
2.	A	3.5

CHAPTER FOUR

AIRCRAFT NATIONALITY AND REGISTRATION MARKS

Contents

INTRODUCTION	55
CERTIFICATION OF REGISTRATION	56
AIRCRAFT MARKINGS	56
CLASSIFICATION OF AIRCRAFT	57
QUESTIONS	58
ANSWERS	60

INTRODUCTION

4.1 Annex 7. The Paris Convention of 1919 requires all aircraft to be registered and to carry a nationality mark and a registration mark. Annex 7 of the Chicago Convention covers Aircraft Nationality and Registration Marks. The Annex contains only Standards without any recommendations. An Authority may temporarily exempt an aircraft from registration (test flying of a prototype) or the carriage of markings (an historic aircraft or ex-military aeroplane).

NATIONALITY AND REGISTRATION MARKS

4.2 Markings. The nationality and registration mark is to consist of a group of characters.

G-ABCD

In this case G is the nationality mark and is always to precede the registration mark, in this case ABCD. When the first character of the registration mark is the same type of character as the last character of the nationality mark, it is preceded by a hyphen (-). The nationality mark is selected from the series of nationality symbols included in the radio call signs allocated to the State of Registry by the International Telecommunications Union (an agency of the United Nations). The nationality mark is to be notified by the State of Registry, to ICAO and may consist of single letters; multiple letters or a combination of letters and numbers. It may also include a symbol of the State (e.g. the Red Cross in the case of Switzerland). The registration mark may consist of letters, numbers or a combination of both and is assigned by the State of Registry, or the common mark registering authority, from a list of available (not previously issued) marks applicable to the State of Registry.



Figure 4.1:

4.3 Common Mark. A common mark replaces a nationality mark where the aircraft is owned (operated) by an operator registered in more than one country. In this case, a 'common mark' is allocated by the ITU, and ICAO specifies a state to exercise the responsibilities of the State of Registry (known as the common mark registering authority). The common mark registering authority also performs the function of the State of Registry with regard to the continuing airworthiness of the aircraft. Presently, the common mark 4YB is issued by ICAO to Arab Air Cargo Incorporated (based in Jordan and Iraq) for registering aircraft operated by that organisation. ICAO has specified that Jordan performs the other functions of the common mark registering authority.

4.4 Exclusions. Certain combinations of letters are not permitted to be used as registration letters or parts of a registration mark. These are those combinations of letters used for specific distress traffic indicators or internationally accepted communication abbreviations. Specifically:

- SOS (Distress - morse)
- PAN (Urgency)
- XXX (Urgency - morse)
- TTT (Safety /Securité - morse)
- 'Q' codes (i.e. QNH; QRT; QUG etc....)
- 5 letter combinations of the international Code of Signals

CERTIFICATION OF REGISTRATION

4.5 Status and Content. The certificate of registration is an official document certifying that the State of Registry has registered an aircraft. The certificate is to be carried in the aircraft at all times. The certificate contains:

- Nationality or Common mark,
- Registration mark,
- Manufacturer's designation of the aircraft,
- Serial number of the aircraft,
- Name and address of the owner,
- A certificate that it has been entered on the register of the State,
- Dated signature of the registering officer.

AIRCRAFT MARKINGS

4.6 Location of Nationality and Registration Marks. The nationality or common mark and registration mark are to be painted on the aircraft or shall be affixed by any other means ensuring a similar degree of permanence. The marks shall be kept clean and visible at all times.

4.7 Heavier than Air Aircraft. The required markings are to appear on the lower surface (underside) of the wing, the fuselage between the wings and the tail, or on the upper half of the vertical tail surface.

4.8 Size of Markings. The markings on the wings are to be at least 50cm high, and on the fuselage and vertical surfaces, 30cm high.

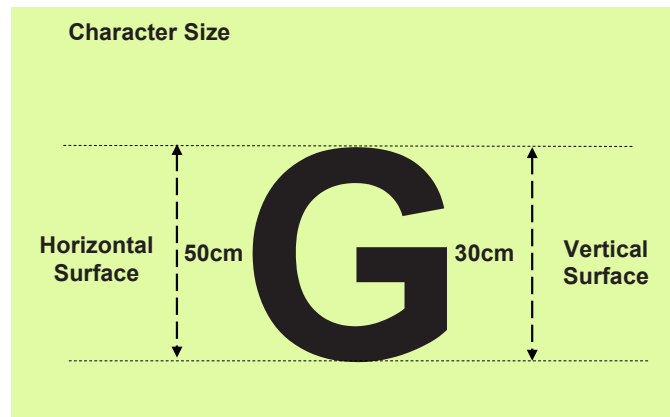

Figure 4.2:

CLASSIFICATION OF AIRCRAFT

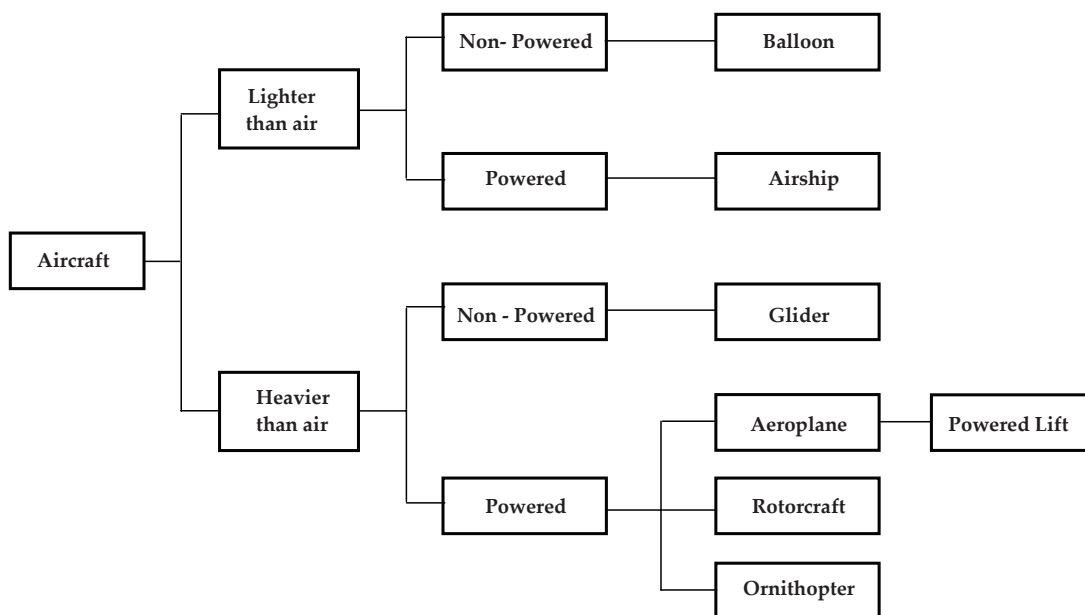

Figure 4.3:

QUESTIONS

1. What cannot be included in a registration mark?
 - a. LLL
 - b. RCC
 - c. TTT
 - d. FFF

2. What letters are prohibited for registration marks?
 - a. 4 letter international codes.
 - b. 5 letter international codes.
 - c. 4 letter codes preceded by Q.
 - d. Any number referring to an ICAO document.

3. Which of the following is not allowed in a registration mark?
 - a. NNN
 - b. XXX
 - c. RCC
 - d. DDD

4. What registration is disallowed because of possible confusion with distress/urgency signals?
 - a. RCC
 - b. NNN
 - c. XXX
 - d. ZZZ

5. Which of the following is not permitted in the registration mark of an aircraft?
 - a. Four letter Q codes.
 - b. Five letter international code signals.
 - c. Three letter international code signals.
 - d. Any number identifying an ICAO document.

6. Concerning aircraft registration, no combination of letters can be used which can be confused with distress codes, for example:
 - a. RCC
 - b. DDD
 - c. LLL
 - d. PAN

7. Which of the following registration marks would not be permitted?
 - a. G-PRAT
 - b. SY-PAN
 - c. 3T-SSS
 - d. YT-LLL

8. Concerning aircraft registration markings, no combinations can be used if they can be mistaken for:
 - a. codes which are used for identification of ICAO documents.
 - b. letter combinations including the letter Q.
 - c. 3 letter combinations which are used by international code of signals.
 - d. 5 letter combinations which are used by international code of signals.

9. According to Annex 7, the registration mark shall be letters, numbers or a combination of letters and numbers and shall be that assigned by:
 - a. the State of Registry or Common Mark Registering Authority.
 - b. the State of Registry only.
 - c. the International Civil Aviation Organisation.
 - d. the International Telecommunication Union.

10. The common mark shall be selected from the series of symbols included in the radio call signs allocated:
 - a. to ICAO by the ITU.
 - b. to the State of Registry by ICAO.
 - c. to the State of Registry by the ITU.
 - d. to the State of the Operator.

11. The height of the markings under the wings of a heavier than air aircraft shall be:
 - a. at least 30 cm.
 - b. at least 40 cm.
 - c. at least 50 cm.
 - d. more than 40 cm but not more than 50 cm.

12. The height of the markings on the fuselage (or equivalent surface) and on the vertical tail surface of a heavier than air aircraft shall be:
 - a. at least 20 cm.
 - b. more than 20 cm but not more than 30 cm.
 - c. at least 30 cm.
 - d. at least 40 cm.

ANSWERS

Question	Answer	Reference
1.	C	4.4
2.	B	4.4
3.	B	4.4
4.	C	4.4
5.	B	4.4
6.	D	4.4
7.	B	4.4
8.	D	4.4
9.	A	4.2
10.	A	4.3
11.	C	4.8
12.	C	4.8

CHAPTER FIVE
FLIGHT CREW LICENSING

Contents

INTRODUCTION 63

DEFINITIONS 63

GENERAL RULES CONCERNING LICENSING 64

LICENCES AND RATINGS FOR PILOTS 66

PRIVATE PILOT LICENCE (AEROPLANE) – PPL(A) 68

COMMERCIAL PILOT LICENCE (AEROPLANE) – CPL(A) 68

AIRLINE TRANSPORT PILOT LICENCE (AEROPLANE) – ATPL(A) 69

MULTI-CREW PILOT LICENCE (MPL) 70

INSTRUMENT RATING (AEROPLANE) (IR(A)) 70

INSTRUCTOR AND EXAMINER RATING 70

JAR-FCL 3 MEDICAL REQUIREMENTS 72

PILOT PROFICIENCY 74

JAA THEORETICAL KNOWLEDGE EXAMINATIONS 74

QUESTIONS 75

ANSWERS 84

INTRODUCTION

5.1 Requirement. The Learning Objectives and the Syllabus for 010 Air Law require the student to have knowledge of the SARPS detailed in Annex 1 (Personnel Licensing). However, the EASA requirement for Flight Crew Licensing is contained in JAR-FCL and there are questions in the CQB relating to JAR-FCL. Where there are JAR differences from Annex 1, these will be highlighted.

5.2 International Standard. Each Annex to the Chicago Convention includes a supplement, which is a summary of the changes notified by each state (in alphabetical order) under article 38 of the convention. The supplement for Annex 1 is the biggest of all the annex supplements and signifies the disparity in flight crew licensing around the world. It must be stated that the FAA, the JAA and certainly the UK CAA have not, and never have, adopted the requirements of Annex 1 (crew licensing and medical requirements) as a standard. Each authority has specific rules, to which, JAR-FCL is the JAA standard applied in Europe. It must be emphasised that the inclusion of information from Annex 1 in this manual is for information only (to enable you to pass the exam) and must not be relied upon for any matters relating to the issue of, or maintenance of your flight crew licence.

5.3 European Standard. The licensing of pilots (also Flight Engineers) to JAR requirements is in accordance with the requirements of JAR-FCL parts 1, 2 3 and 4.

- JAR-FCL 1 covers the licensing of pilots of aeroplanes
- JAR-FCL 2 covers the licensing of helicopter pilots
- JAR-FCL 3 covers the medical requirements for licensing of aircrew
- JAR-FCL 4 covers the licensing of Flight Engineers (Systems Panel Operators)

DEFINITIONS

5.4 Definitions. When the following terms are used in the standards and recommended practices of Annex 1, they have the following meanings:

5.5 Pilot-in-Command (PIC). The PIC is the pilot who is responsible for the safety of the aircraft and compliance with the rules of the air, during flight time.

5.6 Commander. A pilot designated by the operator who is qualified as PIC, who may delegate the responsibility for the conduct of the flight to another qualified pilot.

5.7 Co-pilot. A licensed pilot serving in any capacity other than PIC but excluding a pilot who is on board for the sole purpose of receiving instruction.

5.8 Flight Time. The total time from the moment an aircraft first moves under its own power for the purpose of taking off until it comes to rest at the end of the flight (synonymous with 'block to block' or 'chock to chock').

5.9 Instrument Ground Time. Time during which a pilot is practising, on the ground, simulated instrument flight in a synthetic flight trainer (see def) approved by the authority.

5.10 Rating. An authorisation entered on or associated with a licence and forming part thereof, stating special conditions, privileges or limitations pertaining to such a licence.

5.11 Synthetic Flight Trainer. Any one of the following three types of apparatus in which flight conditions are simulated on the ground:

- **Flight Simulator**, which provides an accurate representation of the flight deck of a particular aircraft type to the extent that the mechanical, electrical, electronic, etc. aircraft systems control functions, the normal environment of flight crew members, and the performance and flight characteristics of that type of aircraft are realistically simulated;
- **Flight Procedures Trainer**, which provides realistic flight deck environment and which simulates instrument responses, simple control functions of mechanical, electrical, electronic, etc. aircraft systems and the performance and flight characteristics of aircraft of a particular class;
- **Basic Instrument Flight Trainer**, which is equipped with appropriate instruments, and which simulates the flight deck environment of an aircraft in flight in instrument flight conditions.

GENERAL RULES CONCERNING LICENSING

5.12 Authority to Act as Flight Crew. A person shall not act as a flight crewmember of an aircraft unless a valid licence is held showing compliance with the specifications of Annex 1 and appropriate to the duties to be performed by that person. The licence shall have been issued by the State of Registry of that aircraft or by any other Contracting State and rendered valid by the state of Registry of that aircraft.

5.13 Re-issue of a JAA Licence. The period of validity of a JAA licence is 5 years. Within this period, the licence will be re-issued by the appropriate JAA authority under the following conditions:

- After initial issue or renewal of a rating
- When paragraph xii. of the licence document is full
- For any administrative reason
- At the discretion of the JAA member State Authority when a rating is re-validated

5.14 Rendering a Licence Valid. A Contracting State may validate a licence issued by another authority, with the proviso that the period of validity is not to extend beyond the original period of validity of the licence. A JAA licence (and associated ratings etc...) issued in accordance with JAR-FCL is to be accepted without further formality in any other JAA member state.

5.15 Validation of a non JAA licence for use in a JAA state. A non JAA licence that includes an instrument rating (IR) may be validated for use in a JAA state for a period not exceeding one year providing the basic licence remains valid in the state of licence issue.

5.16 Credit of Experience. The holder of a non-JAA licence may be credited with theoretical knowledge and/or flying experience at the discretion of the JAA member state authority towards the issue of a comparable JAA licence by that member state.

5.17 Privileges of a Licence. A pilot licence issued by a State grants the holder the privilege to act as a pilot in aircraft registered in that state. A licence (or rating) holder is not permitted to exercise privileges other than those granted by the licence or rating.

5.18 Medical Fitness. The holder of a licence is to hold a medical assessment certificate issued in accordance with the requirements of Annex 1 Chapter 6 (Medical Provisions for Licensing) or in the case of a JAA licence, JAR-FCL part 3. Holders of licences are not to exercise the privileges of their licences if they are aware of any decrease in medical fitness standard (either physical or mental). Licence holders are not to act in any capacity under their licence whilst under the influence of any psychoactive substance. Licence holders are not to engage in any problematic use (or abuse) of substances. Licence holders should seek the advice of an approved aeromedical examiner (AME) before taking any medication over a prolonged period.

5.19 Validity of Licences. A licence (or rating) is only valid if the necessary ratings or certificates (including a medical certificate) are also valid. A licence or rating holder is to maintain competence and meet the requirements for recent experience required by the licence or rating, including the maintenance of a current medical assessment.

5.20 Validity of Ratings. A licence that includes a rating is only valid as long as the rating remains valid. The periods of and methods of maintaining a rating are as follows:

5.21 Instrument Rating (IR). An IR is valid for a period of 12 months. It may be renewed during the last three months of the period of validity of the rating. If an instrument rating test for renewal of a rating is failed, the current IR is cancelled.

5.22 Class and Type Ratings. Multi engines class ratings and Type ratings are valid for 12 months. Single pilot single engine class ratings (including touring motor glider rating) are valid for 2 years. Ratings are valid from the date of issue, or the date of expiry if re-validated within the validity period. The method of renewal of ratings is by passing a pilot proficiency (skill) test.

5.23 Medical Report Periods. Reports of medical fitness are to be submitted at intervals not greater than:

- **CPL(A)/ATPL(A) - Class 1:**
ICAO and JAA: 12 months to age 60 (age 40 if engaged in single pilot operations), then 6 months thereafter.
- **MPL - Class 1:**
ICAO: 12 months to age 60, then 6 months thereafter.
- **PPL(A)- Class 2:**
ICAO: 60 months to age 40, then 24 months thereafter (recommended 12 months after age 50)
JAA: 60 months to age 40, then 24 months to age 50, then 12 months thereafter.

5.24 Medical Examination Deferment. Annex 1 permits a licence holder is operating in a remote area where medical examination facilities do not exist, at the discretion of the authority. It must be stressed that this is not a JAA acceptable procedure and a pilot exercising the privileges of a JAA licence must have a valid medical certificate in accordance with JAR-FCL-3. The ICAO requirement for a medical examination may be deferred as follow:

- For a period of 6 months for aircrew not engaged in commercial aviation.
- Two consecutive periods of three months for aircrew engaged in commercial air transport providing a favourable report is obtained after examination or where no approved medical examiner is available a favourable report from a medical practising physician. Such a report is to be sent to the authority of the State of Licence Issue.
- A single period of 24 months for a PPL holder.

5.25 Age. The holder of a pilot licence will not be permitted to act as the pilot of a commercial air transport aircraft once the age of 60 has been reached except when he/she is a member of a multi-pilot crew, and he/she is the only pilot of that crew who has reached the age of 60.

5.26 Age 65. Once the age of 65 is reached, a pilot shall not act as a pilot of an aircraft engaged in commercial air transport. Some JAA states limit this age to 60.

LICENCES AND RATINGS FOR PILOTS

5.27 General Requirements. A person is not permitted to act as PIC or co-pilot in the following categories of aircraft unless he/she holds the appropriate licence. Licence categories are:

- Aeroplane
- Helicopter
- Glider
- Free balloon

5.28 Licence types. Three levels of licence are issued:

- Private Pilot Licence (PPL)
- Commercial Pilot Licence (CPL)
- Air Transport Pilot Licence (ATPL)
- Multi Crew Pilot Licence (MPL)

Note: Licences are referred to by type and category i.e. a commercial pilot licence for an aeroplane is a CPL(A).

5.29 Aeroplane Class Ratings. Class ratings are to be established for aeroplanes certificated for single pilot operation and are to comprise:

- Single-engine, land
- Single-engine, sea
- Multi-engine, land
- Multi-engine, sea

5.30 JAR-FCL Class Rating. Additional ratings are as follows:

- All touring motor gliders
- Each manufacturer of single engine turbo prop land plane
- Each manufacturer of single engine turbo prop sea plane

5.31 Type Ratings. Where required, a type rating will be issued after satisfactory completion of a type rating course for the appropriate type of aeroplane and demonstration of the necessary pilot skill in that type. When a type rating is issued limiting the holder to act as co-pilot only, the rating is to be so endorsed. There is no limit to the number of type (or class) ratings that may be held at any one time, however, the authority suggests that no more than can be maintained safely, should be held simultaneously.

5.32 Criteria. The JAR-FCL criteria upon which type ratings are established is as follows:

- Airworthiness type certificate
- Handling characteristics
- Certified minimum flight crew complement
- Level of technology

5.33 Divisions. Type ratings are required for:

- Each type of multi-pilot aeroplane;
- or
- Each type of single pilot multi-engine aeroplane fitted with turbojet or turbo-prop engines;
- or
- Each type of single pilot single-engine aeroplane fitted with a turbojet engines;
- or
- Any other type of aeroplane if considered necessary by the authority.

5.34 ICAO variations. Annex 1 specifies type ratings for:

- Each type of multi-pilot aircraft; and
- Each type of single pilot operation helicopter; and
- Helicopters certified for single pilot operation (if not covered by a class rating).

5.35 Variants. Within a type rating, difference training may be required for variants of the basic type. If the specific variant has not been flown during a period of 2 years, further difference training is required.

5.36 Multi-pilot conditions. According to JAR-FCL, an applicant for a multi-pilot type rating must have:

- Not less than 100 hours as PIC of aeroplanes
- A valid multi-engine IR(A)
- A certificate of MCC
- Completed the theoretical knowledge course and passed the examinations for ATPL(A)

Note: This requirement is regardless of the type of licence held

5.37 Use of Synthetic Trainers. The licensing authority may approve the use of a synthetic flight trainer for performing any manoeuvre required for the demonstration of skill for the issue of a licence or rating, after it has ensured that the trainer is appropriate for the task.

5.38 When an Instrument Rating (IR) is required. The State of Licence Issue is not to permit a licence holder to act as pilot or co-pilot under Instrument Flight Rules (IFR) unless the holder also holds an Instrument Rating (IR) appropriate to the aircraft category. JAR-FCL permits member states to specify national rules for flight under IFR without an IR(A) i.e the UK IMC rating, however, such authority is limited to the airspace of that state only.

5.39 Instructor Rating. A Contracting State, having issued a pilot licence, is not to permit the holder to carry out flight instruction for the issue of any licence or rating, unless the holder has received the proper authorisation.

5.40 Credit of Flight Time. A student pilot (or the holder of a licence) is entitled to be credited in full with all solo, dual instruction and PIC flight time towards the total flight time required for the initial issue of a pilot licence or a higher-grade pilot licence. When acting as co-pilot of an aeroplane in which a co-pilot is required the pilot is entitled to count not more than 100% of the co-pilot time towards the total flight time required for a higher-grade licence. A pilot acting as co-pilot performing as PIC under supervision, can count the full hours towards the total flight time required for a higher-grade licence.

5.41 Student Pilot. Licence Issuing States are to ensure that student pilots do not pose a hazard to navigation. Student pilots are only permitted to fly solo under the supervision of, or with the authorisation of, an authorised flight instructor. Student pilots are not permitted to fly solo on international flights unless in accordance with an agreement between the contracting states concerned. A student pilot is not permitted to fly solo unless he/she holds at least a class 2 medical assessment.

PRIVATE PILOT LICENCE (AEROPLANE) – PPL(A)

5.42 Age. An applicant for a PPL is to be not less than 17 years of age. Training can be started at any age, but a solo flight is not permitted until the student is 16.

5.43 Knowledge. An applicant for a PPL is required to demonstrate by examination a required level of theoretical knowledge.

5.44 Experience. An applicant for a PPL is to complete not less than 45 hours flight time. Where time in a synthetic trainer is permitted, it is limited to a maximum of 5 hours as part of the required 40 hours. Flight time as pilot in other categories of aircraft may (with authority authorisation) be credited. The applicant is required to have completed not less than 10 hours solo which is to include 5 hours of solo cross country flight time with at least one flight of not less than 270 km (150 nm) which must include full stop landing at two different aerodromes.

5.45 Medical Fitness. A PPL (A) holder must hold a current class 2 medical assessment.

5.46 Privileges. The holder of a PPL (A) may as PIC or co-pilot of any aeroplane engaged in non-revenue (non commercial) flights. If the privilege is to be exercised at night, the holder is to have received dual instruction in aeroplanes flying at night, including take-offs, landings and navigation.

COMMERCIAL PILOT LICENCE (AEROPLANE) – CPL(A)

5.47 Age. An applicant for a CPL(A) is to be not less than 18 years of age.

5.48 Theoretical Knowledge. An applicant for a CPL(A) must have a required level of knowledge, demonstrated by successful passing of examinations, of the following subjects:

- Air Law
- Aircraft general knowledge
- Flight performance and planning
- Human performance and limitations
- Meteorology
- Navigation
- Operational Procedures
- Principles of flight
- Radiotelephony

5.49 Experience. An applicant for a CPL(A) is to complete not less than 200 hours flight time. Where time in a synthetic trainer is permitted, it is limited to a maximum of 10 hours as part of the required hours. For a student completing an integrated CPL(A) course, at least 150 hours including all progress test is to be completed within which up to 5 hours may be instrument ground time. Flight time as pilot in other categories of aircraft may (with authority authorisation) be credited. The applicant is required to have completed not less than:

- 100 hours as PIC (70 in the case of approved course)
- 20 hours cross country flight time with at least one flight of not less than 540 km (300 nm) which must include full stop landing at two different aerodromes.
- 10 hours of instrument instruction time of which not more than 5 hours may be instrument ground time.
- If the privilege is to be exercised at night, 5 hours night flight time including 5 take-offs and landings as PIC.

5.50 Medical Fitness. A CPL(A) holder must hold a current class 1 medical assessment.

5.51 Privileges. The holder of a CPL(A) is permitted to exercise all the privileges of a PPL(A); to act as PIC of any aeroplane engaged in operations other than commercial air transport; to act as PIC in commercial air transport in aeroplanes certificated for single pilot operation; to act as co-pilot in commercial air transport in aeroplanes that require a co-pilot (JAR-FCL requires a CPL(A) holder to have passed the theoretical knowledge for ATPL(A) prior to starting type rating training for multi-pilot aeroplanes engaged in commercial air transportation). If the privilege is to be exercised at night, the holder is to have received dual instruction in aeroplanes flying at night, including take-offs, landings and navigation.

AIRLINE TRANSPORT PILOT LICENCE (AEROPLANE) – ATPL(A)

5.52 Age. An applicant for a ATPL(A) is to be not less than 21 years of age.

5.53 Theoretical Knowledge. An applicant for a ATPL(A) must have knowledge of the same subjects detailed in paragraph 5.6.2 but to a more demanding level determined by examination.

5.54 Experience. An applicant for a ATPL(A) is to complete not less than 1500 hours flight time and to demonstrate the ability to pilot multi-crew aeroplanes under IFR. Where synthetic trainer time is permitted, it is limited to a maximum of 100 hours as part of the required hours provided that not more than 25 hours have been acquired in a flight procedure trainer or a basic instrument trainer. Flight time as pilot in other categories of aircraft may (with authority authorisation) be credited. The applicant is required to have completed not less than:

- 250 hours as PIC which can be made up of not less than 100 hours PIC and the additional hours as co-pilot acting as PIC under supervision provided that the method is approved by the authority.
- 200 hours cross country flight time with not less than 100 hours PIC or co-pilot acting as PIC under supervision provided that the method is approved by the authority.
- 75 hours instrument time of which not more than 30 hours may be instrument ground time.
- 100 hours night flight time as PIC or co-pilot.
- JAR-FCL additionally requires 500 hours multi-pilot operations in transport, commuter category aeroplanes (or equivalent code).

5.55 Medical Fitness. A ATPL(A) holder must hold a current class 1 medical assessment.

5.56 Privileges. The holder of a ATPL(A) is permitted to exercise all the privileges granted to the holder of a PPL(A) and CPL(A) and of an IR(A); and to act as PIC and co-pilot of any aeroplane engaged in commercial air transport.

MULTI-CREW PILOT LICENCE (MPL)

5.57 Concept. ICAO PANS Training defines the MPL as a licence that permits the holder to exercise the privileges of a co-pilot in commercial air transport on multi-crew aeroplanes (aeroplanes which require a flight crew of at least two pilots). It permits pilots to be trained directly as co-pilots rather than under the CPL or ATPL system that trains PICs.

5.58 Limitations. As the licence is designed for co-pilots of multi-crew aeroplanes, the holder of an MPL will not be able to exercise the privilege of the licence on single pilot operation aeroplanes.

5.59 Licence Specification. It is expected that the specification for the MPL will broadly follow the example of the JAA 'frozen' ATPL(A)

INSTRUMENT RATING (AEROPLANE) (IR(A))

5.60 Requirements for Issue. The knowledge requirements for an IR(A) are related to the privilege of the rating, specifically, to operations under IFR. The skill requirement also specifically requires the applicant to demonstrate the ability to operate multi-engine aeroplanes solely with reference to instruments with one engine inoperative, if a pilot is to fly IFR in such aeroplanes. The regulations permit the use of synthetic trainers to demonstrate skills.

5.62 Experience. The applicant is to hold a PPL(A) with a night qualification, or a CPL(A), and have completed 50 hours of cross country flight time as PIC in aeroplanes or helicopters, of which not less than 10 hours shall be in aeroplanes.

5.63 Medical. Holders of PPL(A) are required to comply with the hearing requirements for class 1 certification and contracting states should consider requiring the PPL holder to pass the physical, mental and visual requirements of class 1.

5.64 Privileges of an IR(A). Providing the holder of an IR(A) is also the holder of the appropriate licence and is medically fit (certificated), the holder is permitted to fly aeroplanes under IFR. If a pilot holds both an aeroplane and a helicopter licence, the privilege to fly both types under IFR may be conferred by a single instrument rating.

5.65 Conditions. In states where flight in VMC at night is not permitted, holders of a PPL(A) or a CPL(A) without an IR(A) may (under national rules) be granted a night rating permitting flight at night in VMC under IFR. Additionally, states may (under national rules) grant an IMC rating permitting flight outside controlled airspace (which may include exemptions for flight in some CTRs) in meteorological conditions less than VMC during daytime, to pilots without an IR(A).

INSTRUCTOR AND EXAMINER RATING

5.66 Instructor Categories. There are six categories of aeroplane instructor ratings:

- Flight Instructor – Aeroplane (FI(A))
- Type Rating Instructor – Aeroplane (TRI(A))
- Class Rating Instructor – Aeroplane (CRI(A))
- Instrument Rating Instructor – Aeroplane (IRI(A))
- Synthetic Flight Instructor – Aeroplane (SFI(A))
- Multi-crew Co-operation Course Instructor - Aeroplane MCCI(A)

5.67 Prerequisites. All instructors are required to hold at least the licence, rating or qualification for which instruction is given and shall be entitled to act as PIC of the aeroplane during such instruction.

5.68 Period of Validity. Instructor ratings are valid for 3 years.

5.69 Flight Instructor Rating - Aeroplane (FI(A)). The following are the conditions which apply to the granting of an FI(A) rating:

- Minimum age 18
- Must be supervised until:
 - Completed 100 hours of instruction
 - Supervised 25 student solo flights

5.70 Pre-requisites. Before beginning the course of training for a FI(A) rating the applicant is to have:

- A CPL(A) or 200 hours flight time of which 150 as PIC if holding a PPL(A)
- The theoretical knowledge of a CPL(A) holder
- Completed 30 hours in single engine piston powered aeroplanes with at least 5 hours in the last six months
- Received at least 10 hours of instruction (of which not more than 5 is instrument ground time)
- Completed at least 20 hours of cross country as PIC (distance and landings as per CPL(A))
- Passed a pre-entry flight test

5.71 Unrestricted Privileges. The following are the unrestricted privileges of a FI(A) (with specific experience conditions as per JAR-FCL 1.330). To conduct flight instruction for:

- The issue of a PPL(A)
- The issue of class and type ratings for single engine aeroplanes
- The issue of a CPL(A) 500 hours flight time, 200 hours instructional
- Instruction at night providing a night qualification is held
- The issue of an IR(A) for single engine aeroplanes
- The issue of an IR(A) for multi-engine aeroplanes
- The issue of single-pilot multi-engine type or class ratings
- The issue of a FI(A) rating

5.72 Examiners. Five roles of an examiner are recognised:

- Flight examiner (FE(A)).
- Type rating examiner (TRE(A))/Synthetic flight examiner (SFE(A)).
- Class rating examiner (CRE(A)).
- Instrument rating examiner (IRE(A)).
- Flight instructor examiner (FIE(A)).

5.73 Requirement. Examiners shall hold a licence and rating at least equal to the licence or rating for which they are authorised to conduct skill tests or proficiency checks and, unless specified otherwise, the privilege to instruct for this licence or rating.

5.74 Period of Validity. An examiners authorisation is valid for not more than three years. Examiners are re-authorised at the discretion of the Authority.

JAR-FCL 3 MEDICAL REQUIREMENTS

5.75 Requirement. In order to apply for, or to exercise the privileges, of a licence, the applicant or the holder shall hold a medical certificate issued in accordance with the provisions of JAR-FCL 3 (Medical) and appropriate to the privileges of the licence. The holder of a medical certificate shall be mentally and physically fit to safely exercise the privileges of the applicable licence.

5.76 JAR-FCL Medical certificates. JAR-FCL defines two classes of medical assessment certificates for pilots:

- Class 1 for commercial pilots (CPL and ATPL)
- Class 2 for private pilots (PPL)

5.77 ICAO Medical Certificates. ICAO defines three medical assessment classes:

- Class 1 for commercial pilot licence and flight engineer and navigator licences
- Class 2 for private pilot licences (including glider and free balloon)
- Class 3 for Air Traffic Controllers

5.78 Aeromedical Disposition. After completion of the examination the applicant shall be advised whether fit, unfit or referred to the Authority. The authorised medical examiner (AME) shall inform the applicant of any condition(s) (medical, operational or otherwise) that may restrict flying training and/or the privileges of any licence issued. In the event that a restricted medical certificate is issued which limits the holder to exercise pilot-in-command privileges only when a safety pilot is carried, the authority will give advisory information for use by the safety pilot in determining the function and responsibilities.

5.79 Periodic Medical Examination. The annual medical examination is effectively a health check and takes into account the aging process since the issue of the original certificate. Providing the pilot has medical examinations at the required intervals, the aging process will be taken into account. Under the JAA regulations, extensions (deferment of medical examination) of medical certificate validity are not permitted. For further requirements see 5.23

5.80 Decrease in Medical Fitness. Licence holders are not to exercise the privileges of their licences if they are aware that they are unwell. In such circumstances they are to seek the advice of the Authority or AME. Such circumstances are:

- Hospital or clinic admission for more than 12 hours
- Surgical operation or invasive procedure
- The regular use of medication
- The need for regular use of correcting lenses

5.81 Operational Multi-crew Limitation (OML). In the circumstance where a commercial pilot does not fully meet the requirements for the issue of a class 1 certificate, the certificate may be annotated with the limitation 'valid only as or with qualified co-pilot'. In such a case, the other pilot must be qualified on type, not be over 60 and not be subject to an OML.

5.82 Medical Conditions. Every licence holder who is aware of:

- Any significant personal injury involving incapacity to function as flight crew
- Any illness involving incapacity to act as flight crew throughout a period of 21 days or more
- Being pregnant

Shall inform the authority in writing of such injury or pregnancy, and as soon as the period of 21 days has elapsed in the case of illness. The medical certificate shall be deemed to be suspended upon the occurrence of a - c above. In the case of injury or illness, the suspension shall be lifted on being pronounced fit after a medical examination. The authority may exempt the holder from such an examination. In the case of pregnancy, the suspension may be lifted for such period by the Authority and subject to such conditions as it thinks fit and shall cease upon the holder being medically examined after the pregnancy has ended and being pronounced fit. If this procedure is complied with, the medical certificate shall be suspended (cannot expire) during the period of illness or injury and will be reinstated once the crew member becomes fit.

5.83 Suspension of Medical Certificate. Provided the authority is notified immediately in the event of injury or when pregnancy is diagnosed, or on the 21st day of prolonged illness, the medical certificate of the holder will be suspended until the holder is passed as fit to resume aircrew duty. At this point the certificate will be reinstated with a remaining validity period equal to that extant at the time that it was suspended. After a female pilot has been diagnosed as pregnant, she may be permitted to continue flying duty until such a date as the medical authority deems that it is no longer prudent for the health of the embryonic baby or the mother to continue to be engaged in flying duty. After delivery and after a medical examination, she will then be declared fit to resume duty at which point the certificate will be reinstated.

5.84 Validity of Medical Certificates. A medical certificate is valid from the date of the initial general medical examination. It may be renewed during the period of validity or as below. If a licence holder allows the certificate to expire by more than 5 years renewal will require initial or extended aeromedical examination (at AMEs discretion). Such an examination shall be carried out at an AMC which has obtained the certificate holder's medical records. If the certificate has expired by more than 2 years but less than 5 years, a standard or extended examination will be required at an AMC or by an AME (if approved by the AMS) subject to the records of medical examinations being made available. If the certificate expires by more than 90 days but less than 2 years, a standard or extended examination performed at an AMC or by an AME (if approved by the AMS) will be required. If a certificate has expired by less than 90 days, renewal shall be possible by standard or extended examination as prescribed.

5.85 45-Day rule. If the medical revalidation is taken up to 45 days prior to the expiry date, the validity of the new certificate extends from the previous certificate expiry date. In other words, if your certificate expires on 31st December and you have your annual medical no earlier than 15th November, the new certificate will be valid from 1st January until the next 31st December. However, if you have a medical on 1 November, the certificate will be valid from 1st November until the following 31st October.

PILOT PROFICIENCY

5.86 Pilot Proficiency Checks. Pilots are required to demonstrate piloting technique and the ability to execute emergency procedures and that such skill is checked. Where flight under IFR is required, the checks required are to be carried out twice a year with any two similar checks not conducted within four months.

5.87 Base and Line Checks. According to both ICAO and JARs, operators are required to carry out checks of pilot proficiency at regular intervals. They are known as base or line checks and are usually coincident with other proficiency checks carried out for validation of type ratings and instrument ratings. These checks meet the requirements of paragraph 5.86 above.

JAA THEORETICAL KNOWLEDGE EXAMINATIONS

5.88 Requirement. Applicants for a JAA professional pilot licence or an instrument rating are required to demonstrate a level of knowledge appropriate to the privileges of the licence or rating by means of success in passing examinations. The examination is to be set in a language considered appropriate by the authority. The format of the examination is to be by multiple choice answer format set by computer from a central question bank (CQB).

5.89 Pass standards. The pass mark is 75%. All the examinations must be passed within a period of 18 months from the end of the calendar month in which the first examination was attempted. All previous examination passes will be rendered invalid if a candidate fails one particular subject at the fourth attempt. All previous examination passes will be rendered invalid if a candidate fails to record a pass in all subjects within either 6 sittings or the above mentioned 18 month period.

5.90 Acceptance period. A pass in the theoretical knowledge examinations will be accepted for the grant of a CPL(A) or IR(A) during the 36 months from the date of gaining a pass in all the required subjects. Providing that an IR(A) is obtained within the 36 months stated above, a pass in the ATPL(A) theoretical knowledge examinations will remain valid for a period of 7 years from the last validity date of the IR(A) entered in the CPL(A) for the issue of an ATPL(A).

QUESTIONS

1. According to JAR-FCL class ratings shall be established for single pilot aeroplanes not requiring a type rating including:
 - a. all touring motor gliders.
 - b. all types of single pilot, single engine aeroplanes fitted with a turbojet engine.
 - c. microlights having fixed wings and moveable aerodynamic control surfaces acting in all three dimensions.
 - d. any other type of aeroplane if considered necessary.
2. Which of the following is the privilege of the holder of a CPL (A)?
 - a. To act as PIC of any aeroplane engaged in operations other than commercial air transportation.
 - b. To act as PIC of any aeroplane engaged in commercial air transportation.
 - c. To act as PIC of any aircraft certificated for single pilot operation other than commercial air transportation.
 - d. To act as co-pilot of any aircraft engaged in commercial air transport operations.
3. What age do you need to be to exercise the privileges of a CPL licence?
 - a. 18
 - b. 21
 - c. 16
 - d. 23
4. When you are over 60 and the holder of an ATPL (A), how often are you required to have a medical examination?
 - a. The 12 month period reduces to 6 months.
 - b. The 24 month period reduces to 12 months.
 - c. The 6 month period reduces to 3 months.
 - d. The 9 month period reduces to 3 months.
5. You can use simulator hours towards the 1500 hours required for an ATPL. How are simulator hours limited?
 - a. Maximum of 100, not more than 15 in a procedural flight trainer.
 - b. Maximum of 100, not more than 30 in a procedural flight trainer.
 - c. Maximum of 100, not more than 25 in a procedural flight trainer.
 - d. Maximum of 100, not more than 50 in a procedural flight trainer.
6. What is the night flying hours requirement for an ATPL(A) licence?
 - a. 75 hours PIC.
 - b. 100 hours PIC or co-pilot.
 - c. 100 hours PIC.
 - d. 75 hours PIC or co-pilot.

7. One of the privileges of the holder of a CPL(A) is to:
- act as Co-pilot of aircraft in commercial air transport operations.
 - act as PIC of single engine aeroplanes in commercial air transport operations.
 - act as a flying instructor.
 - act as PIC of aeroplanes involved in operations other than commercial air transportation.
8. Included in the requirements for 1500 hours, an ATPL(A) holder must have:
- 500 hours multipilot operations in transport; commuter or equivalent category aircraft.
 - 500 hours multipilot operations and 250 hours as PIC.
 - 500 hours multipilot operations including up to 150 hours flight engineering time.
 - 500 hours multipilot operations including 200 hours night time.
9. When are you required to tell the authorities of an illness?
- After the period of 21 days of illness has elapsed.
 - On the 21st day of the illness.
 - After a month.
 - After medical has expired.
10. To obtain a CPL(A), how many hours of cross country flying are required?
- 15 hrs.
 - 20 hrs.
 - 25 hrs.
 - 35 hrs.
11. What medical is required for the issue of a CPL(A)?
- Class 2.
 - As required by particular state.
 - Class 1.
 - JAR Class A (as from 1 Jan 2001).
12. The holder of a pilot licence when acting as co-pilot under supervision of the PIC and performing the functions and duties of the PIC shall be entitled to be credited:
- with 50% of the flight time towards the total time required for a higher grade of licence.
 - in full, but not more than 300hrs towards the total time required for a higher grade of licence.
 - the flight time in full towards the total time required for a higher grade of licence.
 - the flight time in full towards the total time required for a higher grade of pilot licence according to the requirements of the licensing authority.
13. For an ATPL(A), how many night hours are required?
- 30
 - 75
 - 100
 - 150

14. For an ATPL, how many cross-country hours are required, and how many of these must be as pilot in command?
 - a. 200/100
 - b. 200/75
 - c. 150/75
 - d. 250/75

 15. How long would you have to spend in a clinic or hospital before you would have to inform the authorities?
 - a. 24 hrs or more.
 - b. Not less than 20 days.
 - c. More than 12 hours.
 - d. 12 days or more.

 16. When you are a newly qualified flying instructor you have to be supervised by a qualified flying instructor. When will the period of supervision cease?
 - a. Once you have passed a competency check.
 - b. When you have completed 100 hours instruction and sent 25 students solo.
 - c. When you have completed 25 hours instruction and sent 100 students solo.
 - d. When you have completed 100 hours solo.

 17. Between what ages can you exercise the privileges of an ATPL(A) on an unrestricted basis?
 - a. 21 - 60
 - b. 21 - 59
 - c. 18 - 59
 - d. 18 - 60

 18. How long would a non JAA licence be valid for if validated for use in a JAA state?
 - a. Not less than 6 months.
 - b. 12 months from the date of validation.
 - c. 12 months providing the licence is still valid in the State of Issue.
 - d. Not more than 3 months.

 19. Which of the following correctly identifies the cross country hours requirement for a CPL(A)?
 - a. 100 hours PIC or SPIC.
 - b. 20 hours cross country as PIC including a cross country flight not less than 540 km (300 nm) in the course of which full stop landings are made at two different aerodromes.
 - c. 25 hours including at least one flight of 2 hours duration covering at least 300 nm and to include 2 full stop landings.
 - d. 10 hours solo with at least one flight over 300 nm with at least two full stop landings.

 20. What is the minimum age for a holder of a PPL?
 - a. 16
 - b. 17
 - c. 18
 - d. 21
-

21. What is the period of validity of a JAR-FCL class 2 medical?
- 24 months until age 30, then 24 months until 50, then 12 months thereafter.
 - 24 months until age 30, then 12 months until 50, then 6 months thereafter.
 - 60 months until age 40, then 24 months until 50, then 12 months thereafter.
 - 60 months until age 30, then 24 months until 50, then 12 months thereafter.
22. A PPL(A) or Commercial licence holder, before taking his/her Instrument Rating, must have completed hours of cross country of whichhours must be in an aeroplane ?
- 50 15
 - 50 10
 - 40 15
 - 40 10
23. A PPL(A) holder shall demonstrate competence for an IR(A) in a..... aircraft type with ?
- Amphibian all engines running only
 - Seaplane one engine inoperative
 - Multi-engined one engine inoperative
 - Multi-engined all engines running
24. Of the 1500 hours required experience for an ATPL(A). hours may be in a simulator but not more than hours may be in a basic instrument trainer or basic procedure trainer.
- 100 15
 - 100 20
 - 100 25
 - 75 25
25. Which of the following types of aircraft requires a type rating?
- Each type of multi engine aircraft.
 - Each type of single pilot multi-engined turbine.
 - Each type of micro-light with fixed wings and able to move its surfaces in three dimensions.
 - Each type of touring motor glider.
26. To have an unrestricted FI(A) rating and to instruct for the issue of a CPL(A) or a PPL(A.), you must have a CPL(A) or:
- at least 250 hours as a pilot.
 - not less than 15 hours in the last 12 months on the relevant type.
 - at least 200 hours of flight instruction.
 - 200 hours flight time of which not less than 150 hours is PIC.
27. According to JAR-FCL, what classes of medical exist?
- Class 1 only.
 - Classes 1 and 2.
 - Classes 1, 2 and 3.
 - Classes 1, 2, 3 and 4.

28. According to JAR-FCL, a single engine class rating is valid for:
- 2 years.
 - 2 years up to the age of 40 then 1 year thereafter.
 - 5 years after licence issue.
 - 1 year.
29. The validity of a multi-engine class rating or a type rating shall be 1 year from:
- date of issue or the date of expiry if re-validated within the validity period.
 - date of application received by the authority.
 - date of skill test.
 - date of medical examination.
30. In order to carry out PPL(A) instruction you must:
- hold a PPL(A) with instrument rating.
 - have passed the CPL theoretical knowledge exams and hold a FI(A) rating.
 - hold a CPL(A)/IR(A).
 - hold an ATPL(A).
31. For a pilot to hold an ATPL(A), the hours required are:
- 500 PIC, or 300 PIC and 200 as co-pilot acting as PIC under supervision.
 - 200 PIC, or 100 PIC and 100 as co-pilot acting as PIC under supervision.
 - 250 PIC, or 150 PIC and 100 as co-pilot acting as PIC under supervision.
 - 250 PIC, or 100 PIC and the remainder of the hours as co-pilot acting as PIC under supervision.
32. A pilot holding a CPL(A) can act as:
- PIC of any aircraft in non-commercial aviation.
 - PIC in any single engine aeroplane engaged in commercial aviation.
 - PIC of any single pilot aeroplane engaged in commercial aviation.
 - PIC in any aircraft for which he/she is class/type rated engaged in non-commercial aviation.
33. From what date is a medical certificate valid from?
- The date of the initial general medical examination.
 - The date the certificate delivered to the pilot.
 - The date of licence issue.
 - The date of the revalidation of the licence.
34. Which of the following Annexes of the Chicago Convention contains the minimum specification for a crew member's licence to be recognised by Contracting States?
- Annex 2.
 - Annex 3.
 - Annex 1.
 - Annex 4.

35. For the holder of a commercial pilot's licence for single pilot fixed-wing and helicopters who has attained the age of 40, the period between medical reports decreases from:
- 12 months to 6 months.
 - 60 months to 24 months.
 - 24 months to 6 months.
 - 24 months to 12 months.
36. An applicant for an ATPL(A) for aircraft shall have at least:
- 100 hours night flying purely as PIC.
 - 75 hours night flying as PIC or as co pilot.
 - 100 hours night flying as PIC or as co pilot.
 - 75 hours night flying as PIC.
37. A CPL(A) applicant undergoing an integrated course of flight training shall have completed:
- 150 hours flight time of which 5 hours may be instrument ground time.
 - 150 hours flight time.
 - 200 hours flight time including 10 hours instrument ground time.
 - 200 hours flight time.
38. If an applicant for a CPL(A) wishes to exercise the privileges of the licence at night, flight experience will include:
- 5 hours of night flight including 3 take-offs and 5 landings as PIC.
 - 5 hours of night flight including 5 take-offs and 5 landings as PIC.
 - 5 hours of night flight including 5 take-offs and 5 landings as PIC or co-pilot.
 - 5 hours of night flight including 3 take-offs and 3 landings as PIC or co-pilot.
39. According to JAR-FCL, an instrument rating is valid for:
- one year.
 - two years.
 - the period of validity of the licence.
 - indefinitely.
40. When acting as co-pilot of an aeroplane that requires a co-pilot, the pilot shall be entitled to credit not more than:
- 40% of the co-pilot time towards the total flight time required for a higher grade of licence.
 - 60% of the co-pilot time towards the total flight time required for a higher grade of licence.
 - 100 hours of the co-pilot time towards the total flight time required for a higher grade of licence.
 - 100% of the co-pilot time towards the total flight time required for a higher grade of licence.

41. An applicant for a CPL(A) shall have completed in aeroplanes, not less than:
- 200 hours of flight time including 70 hours as PIC.
 - 150 hours of flight time including 100 hours as PIC.
 - 200 hours of flight time or 150 hours if completed during an integrated course of approved training as a pilot of aeroplanes.
 - 200 hours of flight time including 80 hours as PIC.
42. The holders of pilot licences are required to inform the authority if, through illness, they are unable to undertake those functions to which the licence relates throughout a certain number of days. The number of days is:
- 14
 - 21
 - 28
 - 30
43. The cross-country requirement for the issue of a CPL(A) is to include:
- 20 hours cross country with one flight including 2 full stop landings over a total distance of 270km(150nm).
 - 20 hours cross country with one flight including 2 full stop landings over a total distance of 540km(300nm).
 - 10 hours cross country with one flight including 2 full stop landings over a total distance of 270km(150nm).
 - 15 hours cross country with one flight including 2 full stop landings over a total distance of 540km(300nm).
44. An applicant for a CPL(A) shall hold:
- a current class 3 medical assessment.
 - a current class 2 medical assessment.
 - a current class 1 medical assessment.
 - a current medical assessment to a level prescribed by the authority of the state of licence issue.
45. How many synthetic flight trainer hours may be included by an applicant for an ATPL(A) as part of the 1 500 hours necessary experience?
- 100 hours of which not more than 15 hours have been completed in a flight procedures trainer or basic instrument trainer.
 - 75 hours of which not more than 20 hours have been completed in a flight procedures trainer or basic instrument trainer.
 - 100 hours of which not more than 25 hours have been completed in a flight procedures trainer or basic instrument trainer.
 - 100 hours of which not more than 20 hours have been completed in a flight procedures trainer or basic instrument trainer.

46. According to JAR-FCL, an applicant for an IR(A) shall hold a PPL(A) with a night qualification, or a CPL(A), and have completed at least 50 hours:
- instructional time as student PIC of aeroplanes or helicopters of which at least 10 hours is to be in aeroplanes.
 - cross country time as PIC of aeroplanes or helicopters of which at least 10 hours is to be in aeroplanes.
 - cross country time as a pilot of aeroplanes or helicopters of which at least 10 hours is to be in aeroplanes.
 - instructional time as student PIC of aeroplanes.
47. For which of the following are type ratings established?
- Each type of multi-pilot aeroplane.
 - Each type of single pilot multi-engine aeroplane fitted with turbine engines.
 - Any type of aircraft whenever considered necessary by the authority.
 - All the above answers are correct.
48. According to JAR-FCL, establishment of separate type rating for aeroplanes will be assessed on the basis of three criteria. One of these criteria is that the aeroplane has:
- handling characteristics that require the use of more than one crew member.
 - a certificate of airworthiness issued by a non-JAA state.
 - a certificate of airworthiness issued by the manufacturer.
 - handling characteristics that require additional flying or simulator training.
49. Which Annex to the Chicago Convention contains minimum specifications for a crew licence to have international validity?
- Annex 3.
 - Annex 4.
 - Annex 1.
 - Annex 2.
50. A type rating is applicable to:
- an aeroplane requiring a certificate of airworthiness.
 - an aeroplane with a certificate of airworthiness issued by the state of licence issue.
 - an aeroplane that requires multi-pilot operation.
 - an aeroplane that requires additional skills training.
51. According to JAR-FCL, recognised instructor categories are:
- FI(A); TRI(A); CRI(A); IRI(A) only.
 - FI(A); CRI(A) only.
 - FI(A); TRI(A) only.
 - FI(A); TRI(A); CRI(A); IRI(A); MCCI(A) and SFI(A) only.
52. When a state renders valid a licence issued by another Contracting State, as an alternative to issuance of its own licence, the period of validity shall:
- not extend beyond 15 days after the validity of the licence.
 - not extend beyond the period of validity of the licence.
 - shall be at the discretion of the validating state.
 - be at the discretion of ICAO.

53. An applicant for a JAR-FCL ATPL(A) has to demonstrate the ability to pilot:
- a. training aircraft.
 - b. multi-crew aircraft requiring a Flight Engineer.
 - c. multi-crew aeroplanes under IFR.
 - d. night flights with passengers on board.

ANSWERS

Question	Answer	Reference	Question	Answer	Reference
1.	A	5.30	29.	A	5.22
2.	A	5.51	30.	B	5.70
3.	A	5.47	31.	D	5.54
4.	A	5.23	32.	C	5.51
5.	C	5.54	33.	A	5.84
6.	B	5.54	34.	C	5.1
7.	D	5.51	35.	A	5.23
8.	A	5.54	36.	C	5.54
9.	A	5.82	37.	A	5.49
10.	B	5.49	38.	B	5.51
11.	C	5.50	39.	A	5.21
12.	C	5.40	40.	D	5.40
13.	C	5.54	41.	C	5.49
14.	A	5.54	42.	B	5.82
15.	C	5.80	43.	B	5.49
16.	B	5.69	44.	C	5.50
17.	B	5.52 / 5.25	45.	C	5.54
18.	C	5.15	46.	B	5.62
19.	B	5.49	47.	D	5.33
20.	B	5.42	48.	A	5.32 / 5.33
21.	C	5.23	49.	C	5.1
22.	B	5.62	50.	C	5.33
23.	C	5.60	51.	D	5.66
24.	C	5.54	52.	B	5.15
25.	B	5.33	53.	C	5.54
26.	D	5.70			
27.	B	5.76			
28.	A	5.22			

CHAPTER SIX
RULES OF THE AIR

Contents

HISTORY	87
APPLICABILITY OF THE RULES OF THE AIR	87
GENERAL RULES	89
VISUAL FLIGHT RULES	105
INSTRUMENT FLIGHT RULES	106
SEMI-CIRCULAR FLIGHT LEVEL RULES AND RVSM	108
SPECIAL VFR.	109
DISTRESS AND URGENCY SIGNALS	109
RESTRICTED, PROHIBITED OR DANGER AREAS.	111
SIGNALS FOR AERODROME TRAFFIC	112
QUESTIONS	122
ANSWERS	130

HISTORY

6.1 Education. The rules of the air, like the rules of the road, have evolved as aviation has advanced. Initially, aircraft flew without radios (radio hadn't been invented or when it had, there wasn't an aeroplane big enough to carry the equipment!). Simple rules evolved to attempt to reduce the risk of collisions. Remember, in 1920 an aeroplane flying at 80 or 90 kts was travelling at a previously unimagined speed. Visual signals were required at aerodromes to convey information to pilots and procedures evolved to allow orderly flight in the vicinity of aerodromes and to permit visual navigation en-route. Between the 1920's and WWII, individual states passed legislation to enforce the rules that had become established in those states. With the expansion of commercial aviation during and after the war, the need for standardisation in the rules was evident and this was one topic that was seriously addressed at Chicago in 1944.

APPLICABILITY OF THE RULES OF THE AIR

6.2 Annex 2. Annex 2 of the Chicago Convention details the ICAO Rules of the Air. As mentioned above, the rules were primarily written in the early days for non-radio traffic and some of the requirements may now seem out of date. However, there is still a considerable amount of non-radio traffic in general aviation and those airmen are equally entitled to the protection afforded to commercial air transport, and of course, there is always the possibility of communication failure. The ICAO Rules of the Air apply to aircraft bearing the nationality and registration marks of an ICAO Contracting State, wherever they may be, providing they do not conflict with the rules published by the State having jurisdiction of the territory overflown. The ICAO Council resolved in adopting Annex 2 in April 1948 and Amendment 1 in November 1951, that the ICAO Rules apply without exception over the high seas. (High Seas are defined as the areas of sea outside the territorial limits of any State.) When an aircraft is flying within the airspace of the state of registration, the rules of the air of that state (in the UK as published in CAP393 - The ANO) are applicable. Indeed, for a UK registered aeroplane, the UK rules apply wherever the aeroplane is flown providing there is no conflict with local rules. Where a UK registered aircraft is flying over a foreign state, the rules of the air of that state apply. Do not confuse Rules with Law! The application of the rules can be summarised thus:

- UK registered aircraft over the UK - UK rules apply
- UK registered aircraft over France - French and UK rules apply (French have priority)
- UK registered aircraft over the high seas - ICAO rules apply without exception

6.3 Applicable Rules. The operation of an aeroplane either in flight or on the movement area of an aerodrome is to be in accordance with the general rules and, when in flight, either:

- **The visual flight rules (VFR)**, if the aircraft is flown in visual meteorological conditions (VMC)
- or
- **The instrument flight rules (IFR)**

6.4 IFR or VFR? A pilot may elect to fly in accordance with the Instrument Flight Rules in VMC (he/she may be required to do so by the ATS Authority in certain circumstances). A pilot must fly in accordance with the IFR in IMC. If a pilot elects to fly VFR he/she must do so only where VMC exist.

6.5 Visual Meteorological Criteria. To fly under VFR, the visual meteorological criteria (VMC) must exist. This is defined by altitude (or Flight Level); flight visibility (the forward visibility from the flight deck of an aeroplane in flight), and distance (horizontally and vertically) from cloud, for the relevant classes of airspace. Classes of airspace are discussed fully in Chapter 14 - Airspace but basically, specify what rules are permitted and what type of control (if any) is applied by the Air Traffic Service. It is imperative that you know the VMC.

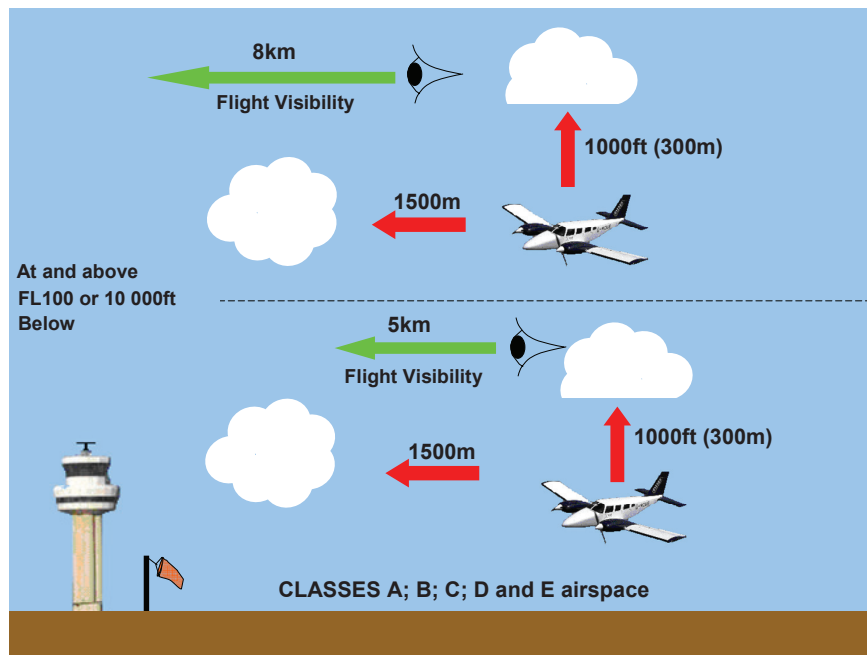

Figure 6.1:

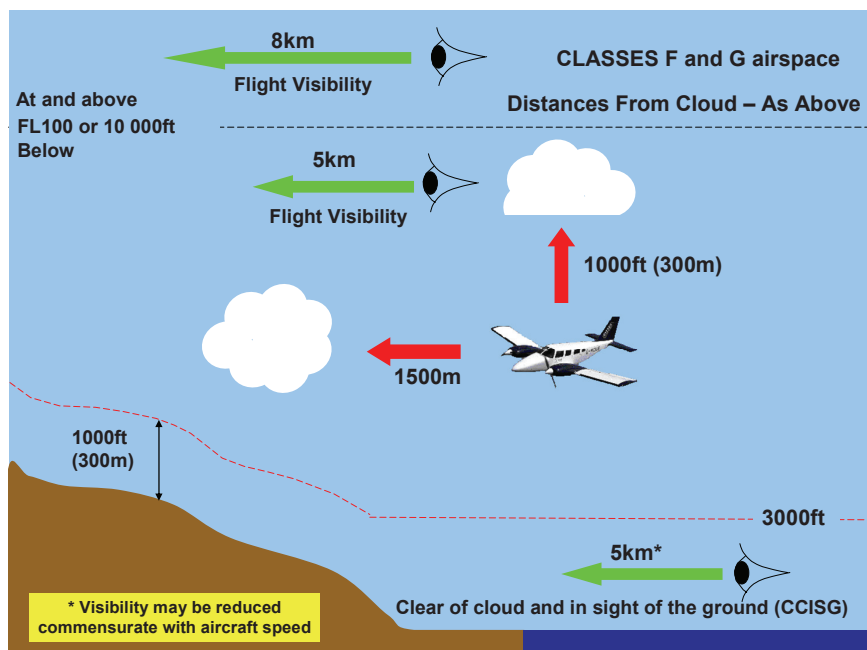

Figure 6.2:

6.6 VMC Criteria Classes A, B, C, D and E Airspace. At and above 10,000 ft (FL100) the flight visibility requirement is 8 km with 300m (1000 ft) vertically, and 1500m horizontally from cloud. Below 10,000 ft (FL100) the flight visibility requirement is reduced to 5km.

6.7 VMC Criteria Classes F and G Airspace. At and above 10,000 ft (FL100) the flight visibility requirement is 8 km with 300m (1000 ft) vertically, and 1500m horizontally from cloud. Below 10,000 ft (FL100) but above 3,000 ft, the flight visibility requirement is reduced to 5km. Below 3,000 ft AMSL and within 1,000 ft of the surface (where surface elevation is above 3,000 ft) the flight visibility remains 5km but VMC would exist if the aircraft was clear of cloud and within sight of the surface.

6.8 Pilot-In-Command Responsibilities. Definitions:

- **Commander:** A designated pilot amongst the flight crew who is qualified as Pilot-In-Command who may delegate the conduct of the flight to another qualified pilot.
- **Pilot-In-Command (PIC):** A pilot who is responsible for the operation and safety of the aeroplane during flight time.
- **Pilot Flying (PF):** The pilot, who for the time being, is in charge of the controls of the aeroplane.
- **Pilot not Flying (PNF):** The pilot who is assisting the pilot flying in accordance with the multi-crew co-operation concept, when the required flight crew is more than one.

6.9 Responsibilities. The commander is responsible for compliance with the Rules of the Air. This applies whether or not he/she is at the controls. The commander has, however, the overriding right to depart from the rules if it is absolutely necessary to do so in the interests of safety. The commander is responsible also for planning the flight. In doing so he/she will study all available weather reports and forecasts, and considering fuel available, will plan an alternative course of action. The commander of an aeroplane has the final authority as to the disposition of the aircraft whilst in command.

6.10 Intoxicating Liquor, Narcotics or Drugs. No person is to pilot an aircraft, or act as a flight crew member of an aircraft, whilst under the influence of intoxicating liquor, any narcotic or drug, by reason of which that person's capacity to act is impaired. ICAO does not lay down any restrictions or maximum blood/alcohol levels for aircrew. However, JAR OPS-1 does. Aircrew are not permitted to exercise the privileges of their licences with a blood/alcohol level exceeding 0.2 promille (20mg/100ml) about one quarter of the UK driving limit. ICAO clearly states that no person may act as aircrew if he/she is under the effect of any psychotropic substance. As professional pilots, you are expected to behave in an adult manner commensurate with the responsibility placed on your shoulders concerning the safety of the passengers in your care. This is an onerous duty which, if it is abused, will result in the full force of the law being applied if you are found negligent in that duty.

GENERAL RULES

6.11 Minimum Heights. Except when necessary for take off or landing, or except by permission of the appropriate authority, aircraft shall not be flown over the congested areas of cities, towns or settlements or over an open-air gathering of persons, unless at such a height as will permit, in the event of an emergency arising, a landing to be made without undue hazard to persons or property on the surface. No specific heights are mentioned and this rule should not be confused with the minimum height rules for IFR or VFR.

Note: The term "aircraft level" is used generally to mean flight level; altitude, or height.



Figure 6.3: An aircraft must be flown at a height from which, in the event of an emergency, a landing can be made without undue hazard to persons or property on the surface.

6.12 Cruising Levels. For flights at or above the lowest usable flight level or where applicable, above the transition altitude, flights shall be conducted in terms of **flight levels**. For flights below the lowest usable flight level or where applicable, at or below the transition altitude, flights shall be conducted in terms of **altitude**.

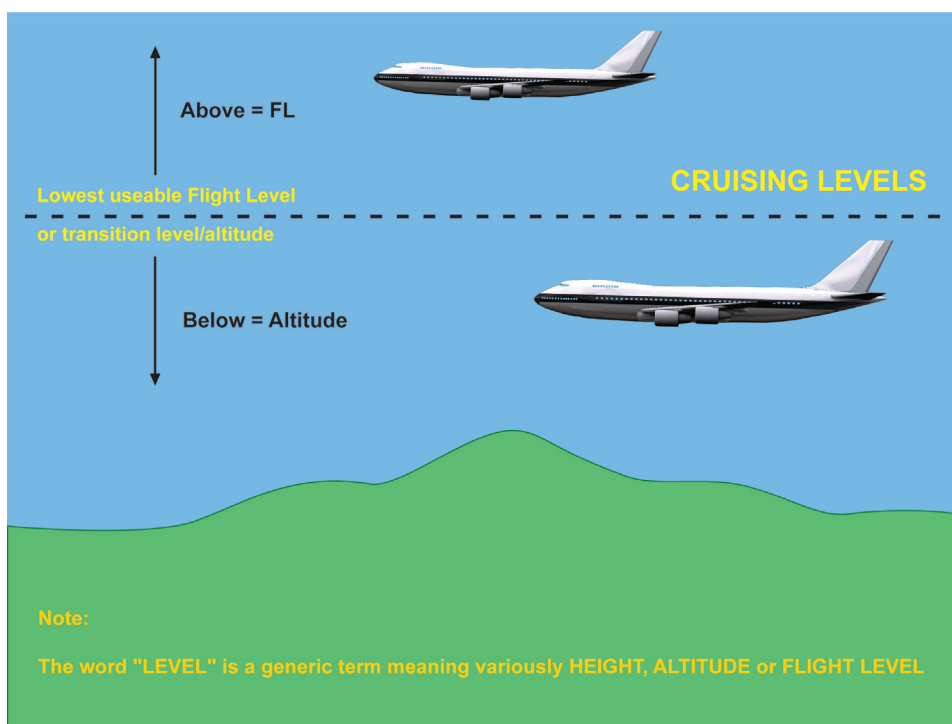

Figure 6.4:

6.13 Proximity and Right of Way. An aircraft shall not be operated in such proximity to

other aircraft as to create a collision hazard. The aircraft that has the right of way shall maintain its heading and speed, but the PIC is still responsible for avoiding collisions (including ACAS alerts). Aircraft which are obliged to give way are to do so and avoid passing over, under or in front of the other unless it is well clear, and to take into account the effect of wake turbulence.

6.14 Approaching Head On. When two aircraft are approaching head on, and there is a danger of collision, each shall alter course to the right. It is generally accepted that where another aircraft is within a sector 20° either side of dead ahead and approaching, that the aircraft are deemed to be approaching each other head on.

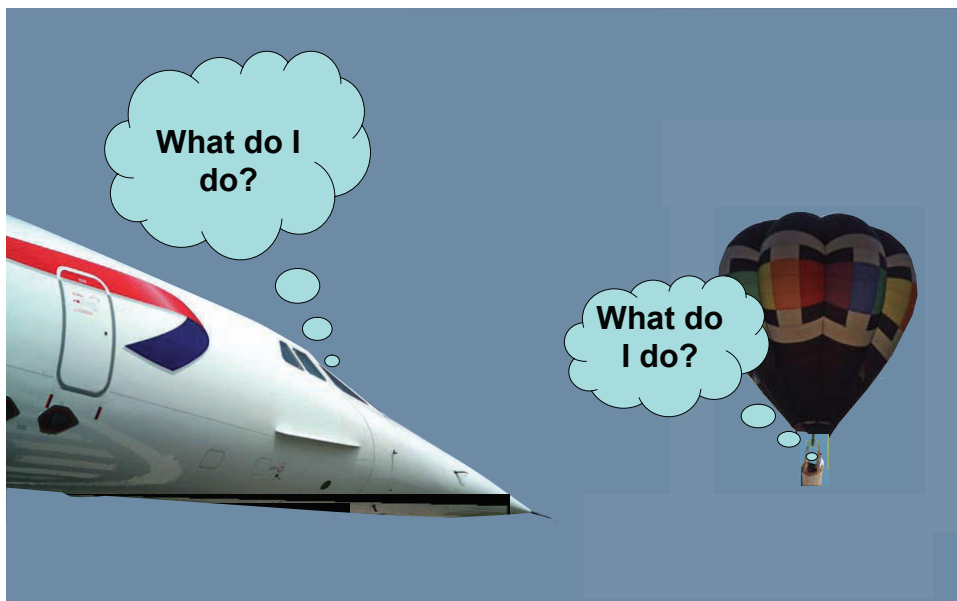

Figure 6.5:



Figure 6.6:

6.15 Converging. When two aircraft of the same type (see definition of aircraft) are converging at approximately the same level, the aircraft that has the other on its right shall give way. In order not to fly over, under or pass in front of the other aircraft, the aircraft that is obliged to give way should pass behind the other aircraft. In order to achieve this, the aircraft giving way should turn right. Where the two aircraft are not of the same type, the following order of priority will apply, and again, the method of giving way is to turn to the right:

- Power driven heavier than air aircraft (aeroplanes) shall give way to airships, gliders and balloons
- Power driven lighter than air aircraft (airships) shall give way to gliders and balloons
- Gliders shall give way to balloons
- Power-driven aircraft shall give way to aircraft which are seen to be towing other aircraft or objects.

(Note: A towing combination is considered to be a single flying machine (not ICAO definition) under the control of the pilot in command of the towing aircraft).



Figure 6.7:

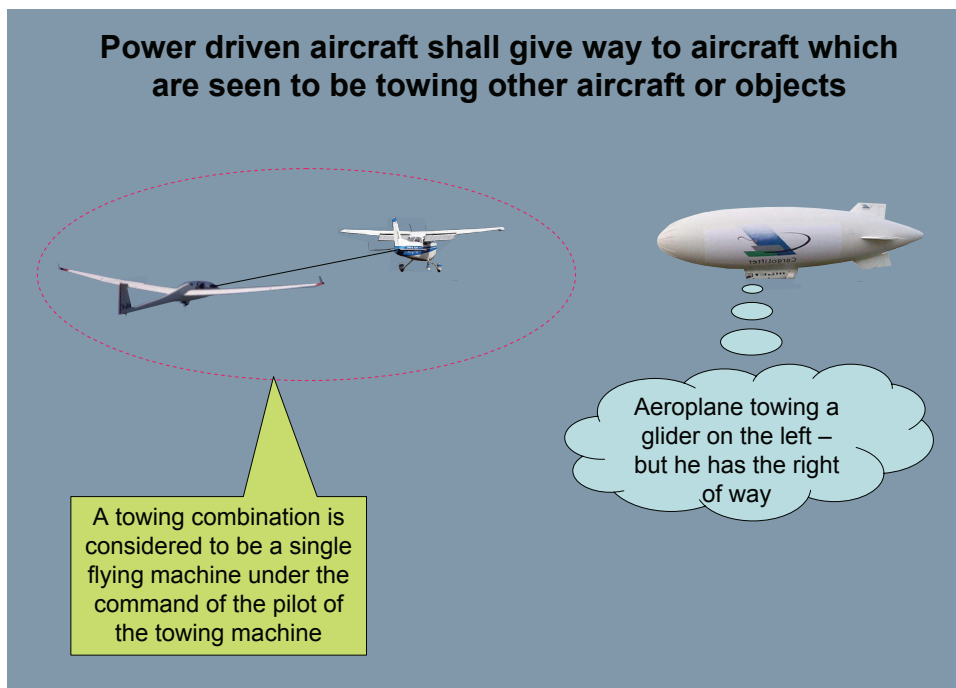

Figure 6.8:

6.16 Overtaking. An overtaking aircraft is an aircraft that approaches another from the rear on a line forming an angle of less than 70° with the plane of symmetry of the latter (at night, the approaching aircraft would see the white tail light of the aircraft in front). An aeroplane that is being overtaken has the right of way and the overtaking aircraft whether climbing or descending or in horizontal flight, shall keep out of the way of the other aircraft by altering its heading to the right and to maintain this position with regard to the other aircraft until well clear.

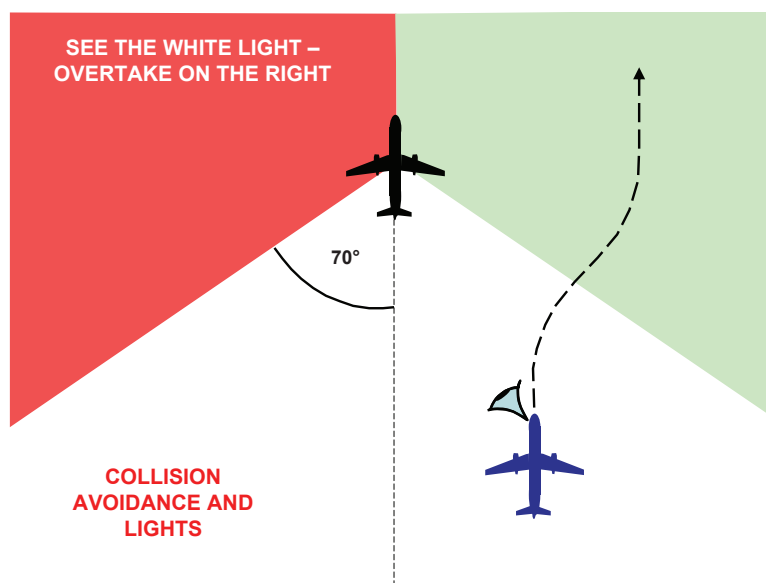

Figure 6.9:

6.17 Landing. An aircraft in flight, or operating on the ground (or water), shall give way to aircraft landing or in the final stages of an **approach to land** (see definition). When two or more heavier than air aircraft are approaching an aerodrome to land, the aircraft at the higher level shall give way to the aircraft at the lower level, but the lower aircraft mustn't take advantage of this rule to 'cut in' in front of another aircraft. In any event, power-driven heavier-than-air aircraft shall give way to gliders.

6.18 Emergency Landing. An aircraft that is aware that another aircraft is in an emergency and is compelled to land, shall give way to that aircraft.

6.19 Taking Off. An aircraft taxiing on the manoeuvring area shall give way to aircraft taking off or about to take off.

6.20 Stop Bars. An aircraft taxiing on the manoeuvring area shall stop and hold at all lighted stop bars (used in poor visibility) and may only proceed when the lights are switched off.

6.21 Surface Movement of Aircraft. In the case of danger of collision between two aircraft taxiing on the movement area (see definition) of an aerodrome, the following shall apply:

- **Approaching head on.** Both stop or where practicable alter course to the right to keep well clear.
- **Converging.** The one that has the other on its right shall give way. (Stop or turn to pass behind).
- **Overtaking.** The aircraft being overtaken has the right of way. The overtaking aircraft is to keep well clear of the other aircraft.

Note: ICAO (Annex 2) states that any vehicle operating regularly on the manoeuvring area of an aerodrome must be in two-way radio contact with ATC. The UK ANO (Rules of the Air - Rule 37) requires all vehicles and aircraft moving on the manoeuvring area to give way to vehicles towing aircraft.

6.22 Aircraft Lights. The systems of displaying navigation lights, anti collision lights and other lights designed to draw attention to the presence of an aircraft, are covered in Operational Procedures. However, you may be asked questions in the Air Law exam on this subject. The law in this matter is restricted to when you must have the lights fitted and when they must be on.



Figure 6.10:

6.23 Lights Displayed by Aircraft. The following lights, required to be shown by aircraft, are to be illuminated from sunset to sunrise (see definition) or during any other period specified by the appropriate authority:

- Anti-collision lights intended to attract attention to the aircraft
- Navigation lights intended to indicate the relative path of the aircraft to an observer. No other lights shall be displayed if they are likely to be mistaken for these lights.

6.24 Sunset to sunrise (or during any other period required by the appropriate authority):

- All aircraft moving on the movement area of an aerodrome shall display navigation lights intended to indicate the relative path of the aircraft to an observer. No other lights shall be displayed if they are likely to be mistaken for these lights.
- All aircraft on the movement area of an aerodrome are to display lights that indicate the extremities of their structure, unless stationary and otherwise adequately illuminated. (Aircraft parked on the Apron (see definition) will be adequately illuminated because an Apron is required to be lit if it is to be used at night. It is usual to use 'glim' lamps to mark the extremities of aeroplanes parked off the Apron).

6.25 Engines Running. All aircraft on the movement area of an aerodrome are to display lights intended to attract attention to the aircraft. Aeroplanes with engines running are to display lights to indicate that fact. Red anti collision lights will suffice for this purpose.

Note: It is usual to indicate that an aeroplane is manned by operating the anti collision light. This serves to warn all personnel that the engines may be started.

6.26 Anti Collision Lights. All aircraft in flight which are fitted with anti-collision lights shall display the lights by day as well as by night. (This is in addition to a. 1. above and is intended to ensure that **if** anti-collision lights are fitted **but are not specifically required** by law, then these lights are also to be illuminated by day as well as night.

6.27 Safety. A pilot is permitted to switch off or reduce the intensity of any flashing lights if they are likely to adversely affect the satisfactory performance of duties, or subject an outside observer to harmful dazzle.

6.28 Simulated IMC. (Definition: Reducing the forward visibility of the Pilot Flying (PF) so that he/she has to rely on instruments for attitude and other flight data). This can be achieved by the use of full or partial flight deck window screens to prevent forward visibility or the use of a visor to 'blinker' the pilot. The most important factor is that simulated IMC is only necessary in VMC. The requirements therefore represent the steps necessary to comply with VFR whilst the visibility of the PF is impaired and he cannot maintain the lookout required by the law.

- An aircraft shall not be flown under simulated IMC unless:
 - Fully functioning dual controls are fitted, and
 - A qualified pilot (need not be type rated) occupies a control seat to act as safety pilot (PNF).

- The safety pilot must have adequate forward vision and to each side of the aircraft. If not, a competent observer (**requirement:** must know what an aeroplane in flight looks like, be able to report any airborne contact clearly and concisely and be able to use the internal communications system of the aeroplane) in communication with the safety pilot, is to occupy a position in the aircraft from which he/she has a field of vision which adequately supplements that of the safety pilot.

6.29 Flight in the Vicinity of an Aerodrome. (*Note:* The pilot of an aeroplane is to plan the route to be flown. At all times he/she is to be aware when the aircraft is being flown in the vicinity of an aerodrome). An aeroplane operated on or in the vicinity of an aerodrome, whether or not within an Aerodrome Traffic Zone (see definition) shall:

- Observe other aerodrome traffic for the purpose of avoiding collisions;
- Conform with, or avoid, the pattern of traffic formed by other aircraft in operation;
- Make all turns to the left when approaching for landing and after taking off, unless otherwise instructed (a right hand circuit!);
- Land and take off into wind unless safety, the runway configuration, or air traffic considerations determine that a different direction is preferable.

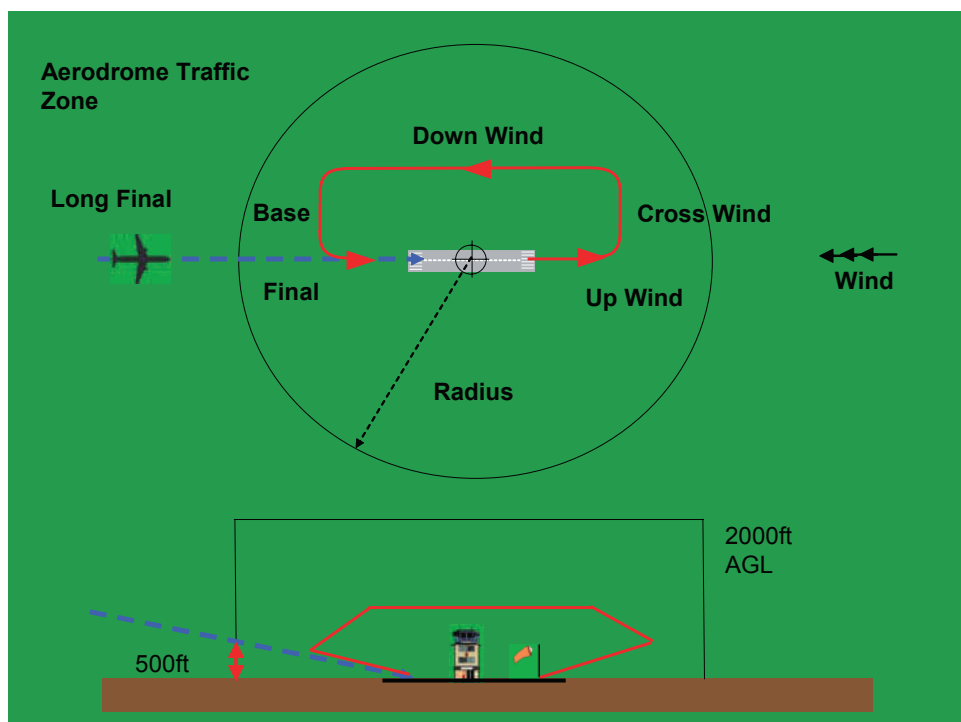

Figure 6.11:

6.30 Flight Plans. (*Note: Do not confuse a flight plan with the form CA48 or equivalent. A flight plan is the means by which ATC is notified of your intention to fly and where necessary, to request a clearance to fly as a controlled flight. The UK CAA form CA48 is a convenient (and approved) method of communicating the necessary information in an orderly form.*)

- A flight plan is to be submitted prior to operating:
 - Any flight or portion thereof to be provided with an air traffic service (a controlled flight - see definition)
 - or
 - Any IFR flight within advisory airspace
 - or
 - Any flight within or into designated areas, or along designated routes, when so required by the appropriate ATS authority to facilitate the provision of flight information, the alerting and search and rescue services
 - or
 - Any flight within or into designated areas, or along designated routes, when so required by the appropriate ATS authority to facilitate co-ordination with appropriate military units (ADIZ) or with air traffic service units in adjacent states in order to avoid the possible need for interception for the purpose of identification
 - or
 - Any flight across international borders (not just FIR boundaries).
- A flight plan shall be submitted before departure to an ATS reporting office (flight planning section, ops room, ATC or FIS office) or, during flight, transmitted to the appropriate ATS unit or air-ground control radio station, unless arrangements have been made for the submission of repetitive flight plans.
- Unless otherwise required by the ATS authority, a flight plan for a controlled flight is to be submitted at least 60 minutes before departure (additional rules apply to flights entering an Oceanic Control Area - OCA), or if submitted in flight, at a time that will ensure its receipt by the appropriate ATSU at least 10 minutes before the aircraft is estimated to reach:
 - The intended point of entry into a control area or advisory area;
 - or
 - The point of crossing an airway or advisory route.
- A flight plan is to contain such of the following as are considered relevant by the appropriate ATS (**note:** the following are not FP field numbers):
 - Aircraft identification;
 - Flight rules and type of flight;
 - Number and type of aircraft and wake category;
 - Equipment;
 - Departure aerodrome;
 - Estimated off blocks time (EOBT);
 - Cruising speed(s) (TAS or Mach No);
 - Cruising level(s);
 - Route to be followed;
 - Destination aerodrome and estimated elapsed time (EET);
 - Alternate aerodrome;
 - Fuel endurance;
 - Total number of persons on board (POB) including dead bodies;

- Emergency and survival equipment;
 - Other information;
- With the exception of inadvertent deviation, all changes to a flight plan submitted for IFR flight or a VFR flight operated as a controlled flight, are to be reported as soon as practicable to the appropriate air traffic services unit. For other VFR flights, significant changes to a flight plan shall be reported as soon as practicable to the appropriate ATSU.

Note: Information regarding fuel endurance or total number of people on board, if incorrect at time of departure constitutes a significant change and must be reported.

6.31 Closing a flight plan/Arrival Report. Unless operator or local procedures apply, a report of arrival is to be made in person, by radio or via data link, as soon as possible after landing to the appropriate ATSU at the arrival aerodrome for any flight, or portion of flight, for which a flight plan has been submitted. On receipt of the arrival report at the ATSU, the flight plan shall be closed. When communications facilities are known to be inadequate and alternative message handling facilities do not exist, a message comparable to an arrival report is to be transmitted by the aircraft. Whenever an arrival report is required, failure to comply with these provisions may cause serious disruption in the air traffic services and incur great expense in carrying out unnecessary SAR operations. An arrival report made by an aircraft is to contain the following:

- Aircraft identification;
- Departure aerodrome;
- Destination aerodrome;
- Arrival aerodrome;
- Time of arrival.

6.32 Time. Co-ordinated Universal Time (UTC) is to be used and is to be expressed in hours and minutes of the 24 hour day beginning at midnight. It is used throughout the world in aviation but you may still find references to either Zulu time or GMT. Where a time check is passed by ATC it is to be to the nearest minute (i.e. 0941 and 20 secs would be 0941; 0941 and 40 secs would be 0942).

6.33 ATC Clearance. An ATC clearance is to be obtained before operating a controlled flight, or a portion of a flight as a controlled flight. The clearance should be requested by the submission of a flight plan to an ATCU. The PIC may request an amended clearance if the issued clearance is unsatisfactory in which case, an amended clearance will be issued if practicable. It is normal practice for an ATC clearance to be passed to the aircraft prior to departure. At busy aerodromes a discrete clearance delivery frequency (RT call sign 'DELIVERY') is usually established leaving the other tower frequencies free for the purpose intended,. The person reading the clearance to the pilot will, in all probability, not be the ATCO issuing the clearance. Before commencing the reading of the clearance you will be asked if you are "Ready to copy?" Your response **when ready**, should be "Go ahead". The clearance will be read to you slowly so that you have the opportunity to write it down, and will be terminated with "read back". You are required to read back the clearance **exactly** as you received it. If your read back is incorrect, the ATCO will read the entire clearance to you again. This will continue until you get it right. There is nothing unprofessional in asking for a repeat or asking for a place name to be spelled. If you don't read it back correctly, at the subsequent board of enquiry into an accident, it will be stated that you didn't understand the clearance as read to you, and you will be held responsible. Don't assume that the air traffic controllers are infallible. If you think something is wrong - query it!

6.34 Adherence to Flight Plan. Flight plans are to be adhered to unless an emergency situation arises which necessitates immediate action by the aircraft. In such a case the ATCU is to be informed as soon as possible. If the average TAS at cruising level between reporting points varies or is expected to vary by +/- 5% of the TAS given in field 7 of the flight plan, the ATCU is to be informed. If an estimate for the next applicable reporting point, FIR boundary or destination aerodrome changes by **more than** 3 minutes from that already notified, the revised time is to be communicated to the appropriate ATCU.

Note: In Operational Procedures for operations in the MNPSA, the requirement is 3 minutes or more.

6.35 Inadvertent Changes. Controlled flights are required to operate along the centre line of an airway or route directly between beacons if that is how the route is delineated. If specified, changeover from one VOR beacon to another is to be at the specified changeover point unless otherwise directed. Any deviation from these requirements is to be reported to ATC. If a controlled flight inadvertently deviates from its current flight plan, action is to be taken immediately to regain the track as soon as practicable.

6.36 Weather Deterioration below VMC. If a VFR flight is unable to maintain VMC in accordance with the current flight plan clearance:

- An amended clearance may be requested enabling the aircraft to continue in VMC (on another route) to destination or to an alternate aerodrome, or to leave the airspace in which ATC clearance is required. If such an amended clearance cannot be obtained to continue to operate in VMC, the pilot must notify the ATCU of the action being taken to either leave the airspace concerned, or to land at the nearest suitable aerodrome.
- If the flight is being operated in a control zone, request special VFR clearance.
- If the above measures are inappropriate, request an IFR clearance to continue.

6.37 Position Reports. Unless advised to cease position reporting (this usually happens when under radar control), a controlled flight is to make reports at specified positions as soon as possible after reaching the position. The report is to contain:

- The aircraft RTF identification call sign
- The position for the report
- The time the aircraft was over the position (usually the minutes will suffice unless there is a possibility of confusion)
- The level of the aircraft when passing the point
- The next en route reporting position
- ETA for the next specified point
- (According to ICAO) the name of the next ensuing point.

Note: If SSR mode "C" has been verified as accurate, altitude/FL may be omitted from the position report. If a speed has been assigned by ATC, this is to be included in the position report.

This is an example of a full ICAO position report:

"London Airways this is GABCD, Pole Hill at 35, FL 170, Dean Cross at 46, Glasgow next"

6.38 Termination of Control. A controlled flight is to advise the appropriate ATCU as soon as it ceases to be subject to air traffic control services. This will be done automatically if the aircraft lands at a controlled aerodrome (one with a control tower). A pilot may be requested to advise ATC when the aircraft leaves controlled airspace.

6.39 Communications Failure. Aircraft operating in accordance with an ATC clearance, where two way radio communications are required, are to comply with the requirements of ICAO Annex 10 (Telecommunications) Volume 2. This specifies the requirement for air-to-ground communications equipment and the radio frequencies allocated to the aeronautical mobile telecommunications network (SELCAL satisfies the requirement to maintain air-ground voice communications). Where Controller-Pilot Data Link Communications (CPDLC) exists, the requirement for voice communications is required to be maintained.

6.40 At a Controlled Aerodrome. If the communications system of the aeroplane (receiver or transmitter) fails when the aeroplane is flying in the traffic pattern at a controlled aerodrome, a watch shall be kept for instructions issued by visual (light and ground) signals from the control tower, and such signals complied with. These signals are specified at 6.9.2

6.41 In VMC. If a failure occurs whilst the aircraft is flying in VMC (regardless of flight rules - VFR or IFR), the aircraft is to continue to be flown in VMC, landed at the nearest suitable aerodrome and arrival reported by the most expeditious means to the appropriate ATCU.

6.42 In IMC. If a failure occurs in IMC:

- If the aircraft is in receipt of a radar vectoring service, the pilot is to squawk A7600 and regain the flight planned track (or SID /STAR route) at the next significant point.
- If the aircraft is en-route and in an area where radar control is provided, the pilot is to squawk A7600 and maintain the current flight plan for a period of 7 minutes and then regain the route and level in accordance with the filed FP, by the most expeditious route.
- If the aircraft is en-route outside of an area where radar control is provided the pilot is to maintain the current flight plan for a period of 20 minutes following the aircraft's failure to report over a compulsory reporting point (at that point the ATCO will know that there is a communication problem), and thereafter adjust level and speed in accordance with the filed flight plan. The 20 minutes is to allow the ATCO time to resolve any potential conflicts that may arise during the transition to the filed flight plan profile.

6.43 Subsequent Actions. After compliance with the above the pilot is to proceed as follows:

- Continue according to the filed flight plan route to the appropriate designated navigation aid serving the destination aerodrome and, when required to ensure compliance with procedure below, hold over this aid until commencement of descent. Then:
- Commence descent from the radio navigation aid in a. above at, or as close as possible to, the expected approach time (EAT) last received and acknowledged. If no EAT has been received and acknowledged, descend at, or as close as possible to, the ETA resulting from the current flight plan.
- Complete a normal instrument approach procedure as specified for the designated aid; and land, if possible, within 30 minutes after the ETA in b. above or the last acknowledged EAT, whichever is the later.

6.44 Unlawful Interference. Where an aircraft is the subject of unlawful interference (hijacking etc.), communication with the appropriate ATC authority is to be attempted to notify the authority of this fact together with any significant circumstances and of any intended deviation from the current flight plan, to enable the ATSU to give priority to the aircraft and to minimise conflict with other aircraft. Attachment B to Annex 2 contains guidance notes for use in this situation. Specifically:

- Unless conditions on the aircraft dictate otherwise, the PIC is to attempt to continue flying on the assigned track and at the assigned level at least until able to notify an ATCU or until within coverage of a radar unit.
- If forced to depart from assigned track/level, without being able to notify ATC, the PIC should, if possible:
 - Attempt to broadcast warnings on the VHF emergency frequency (121.500MHz), and use other on-board systems (i.e. SSR - squawk A/7500, data links etc...) if circumstances permit, and then:
 - Proceed in accordance with applicable special procedures for in flight contingencies established and published in Doc 7030 - Regional SUPPS;
 - If no regional procedures have been established, proceed at a level different from IFR levels by 1 000ft above FL 290, or 500ft below FL290.

6.45 Interception of Civil Aircraft. Each Contracting State has the right to establish procedures for the interception and identification of aircraft flying in the territorial airspace of that State. In formulating the policy for interception, recognising that it is essential for the safety of flight, any visual signals employed during interception by aircraft of a Contracting State, are to be in accordance with Appendix 1 to Annex 2 of the Chicago Convention. The Council has also formulated special recommendations to ensure that the procedures for interception are applied in a uniform manner. The PIC of a civil aircraft, when intercepted is to comply with the standards set out in appendix 2 (sections 2 and 3) to Annex 2, interpreting and responding to visual signals and procedures.

6.46 Carriage of Interception Tables. It is a requirement of national law (UK - ANO; JAA - JAR OPS-1) that aircraft engaged on international flights must carry the interception tables. Clearly, the intent is that in the event of an interception you refer to the tables. You are not expected to learn the content of the tables but you should know what the tables contain. It is suggested that you read the tables to familiarise yourself. These are reproduced at 6.51 / 6.52 below.

6.47 Procedure. An aircraft which is intercepted by another aircraft shall immediately:

- Follow the instructions given by the intercepting aircraft, interpreting and responding to visual signals in accordance with the tables 6.51 and 6.52.
- Notify, if possible, the appropriate Air Traffic Services Unit.
- Attempt to establish radio communication with the intercepting aircraft or with the appropriate intercept control unit, by making a general call on the emergency frequency 121.500 MHz, giving the identity of the intercepted aircraft and the nature of the flight; and if no contact has been established and if practicable, repeating this call on the emergency frequency 243.000 MHz.
- If equipped with SSR transponder, select Mode A, Code 7700 and Mode C, unless otherwise instructed by the appropriate Air Traffic Services Unit.

6.48 Contact with Interceptor. If radio contact with the intercepting aircraft is established but communication in a common language is not possible, attempts shall be made to convey essential information and acknowledgement of instructions by using the phrases and pronunciations as described in table 6.50. If any instructions received from any sources conflict with those given by the intercepting aircraft, the intercepted aircraft shall request immediate clarification while continuing to comply with the instructions given by the intercepting aircraft.

6.49 Interception Phraseology

Phrases used by Intercepting Aircraft			Phrases used by Intercepted Aircraft		
Phrase		Meaning	Phrase		Meaning
Call sign	<u>KOL</u> SA-IN	What is your call sign?	Call sign ²	KOL SA-IN	My call sign is (call sign ²)
Follow	<u>FOL</u> -LO	Follow me	Wilco	<u>VILL</u> -KO	Understood will comply
Descend	DEE- <u>SEND</u>	Descend for landing	Can not	<u>KANN</u> NOTT	Unable to comply
You land	<u>YOU</u> -LAAND	Landing at this aerodrome	Repeat	REE- <u>PEET</u>	Repeat your instruction
Proceed	PRO- <u>SEED</u>	You may proceed	Am lost	<u>AM</u> LOSST	Position unknown
			Mayday	<u>MAYDAY</u>	I am in distress
			Hijack ³	<u>HI</u> -JACK	I have been hijacked
			Land	<u>LAAND</u>	I request to land at (place name)
			Descend	DEE- <u>SEND</u>	I require descent

Table 6.49 - Interception Phraseology

- Notes:**
1. In the second column, the syllables to be emphasised are underlined.
 2. The call sign to be given is that use in the RT communications with ATC corresponding to the aircraft identification on the flight plan
 3. Circumstances may not always permit, or make it desirable, to use 'HIJACK'

6.50 Signals by Intercepting Aircraft and Responses by Intercepted Aircraft

INTERCEPTING Aircraft Signals	Meaning	INTERCEPTED Aircraft Responds	Meaning
<p>DAY-Rocking wings from a position slightly above and ahead of, and normally to the left of the intercepted aircraft and, after acknowledgement, a slow level turn, normally to the left, on the desired heading. NIGHT - Same and, in addition, flashing navigational lights at irregular intervals.</p> <p>Note 1: Meteorological conditions or terrain may require the intercepting aircraft to take up a position slightly above and ahead of, and to the right of the intercepted aircraft and to make the subsequent turn to the right.</p> <p>Note 2: If the intercepted aircraft is not able to keep pace with the intercepting aircraft, the latter is expected to fly a series of racetrack patterns and to rock its wings each time it passes the intercepted aircraft</p>	<p>You have been intercepted follow me</p>	<p>AEROPLANES: DAY-Rocking wings and following.</p> <p>NIGHT-Same and, in addition, flashing navigational lights at irregular intervals.</p> <p>HELICOPTERS: DAY or NIGHT-Rocking aircraft, flashing navigational lights at irregular intervals and following.</p> <p>Note: Additional action required to be taken by intercepted aircraft is prescribed in RAC section.</p>	<p>Understood will comply</p>
<p>DAY or NIGHT-An abrupt breakaway manoeuvre from the intercepted aircraft consisting of a climbing turn of 90 degrees or more without crossing the line of flight of the intercepted aircraft.</p>	<p>You may proceed</p>	<p>AEROPLANES: DAY or NIGHT-Rocking wings.</p> <p>HELICOPTERS DAY or NIGHT- Rocking aircraft</p>	<p>Understood will comply</p>
<p>DAY- Circling aerodrome, lowering landing gear and over flying runway in the direction of landing or, if the intercepted aircraft is a helicopter, over flying the helicopter landing area.</p> <p>NIGHT-Same and, in addition, showing steady landing lights.</p>	<p>Land at this aerodrome</p>	<p>AEROPLANES: DAY-Lowering landing gear, following the intercepting aircraft and, if after over-flying the runway landing is considered safe, proceeding to land.</p> <p>NIGHT-Same and, in addition, showing steady landing lights (if carried).</p> <p>HELICOPTERS: DAY or NIGHT-Following the intercepting aircraft and proceeding to land, showing a steady landing light (if carried)</p>	<p>Understood will comply</p>

6.51 Signals Initiated by Intercepted Aircraft and Responses by Intercepting Aircraft

INTERCEPTED Aircraft Signals	Meaning	INTERCEPTING Aircraft Responds	Meaning
<p>AEROPLANES: DAY-Raising landing gear while have designated passing over landing runway at a height is inadequate exceeding 300 m (1000 ft) but not exceeding 600m (2000 ft) above the aerodrome level, and continuing to circle the aerodrome.</p> <p>NIGHT-Flashing landing lights while passing over landing runway at a height exceeding 300 m (1000 ft) but not exceeding 600 m (2000 ft) above the aerodrome level, and continuing to circle the aerodrome. If unable to flash landing lights, flash any other lights available.</p>	Aerodrome you have designated is inadequate	<p>DAY or NIGHT-if it is desired that the Understood intercepted aircraft follow the intercepting follow me aircraft to an alternate aerodrome, the intercepting aircraft raises its landing gear and uses the Series 1 signals prescribed for intercepting aircraft.</p>	Understood will comply
		<p>If it is decided to release the intercepted aircraft, the intercepting aircraft uses the Series 2 signals prescribed for intercepting aircraft.</p>	Understood you may proceed
<p>AEROPLANES: DAY or NIGHT-Regular switching on and off all available lights but in such a manner as to be distinct from flashing lights.</p>	Cannot comply	DAY or NIGHT - Use Series 2 signals prescribed for	Understood
<p>AEROPLANES: DAY or NIGHT-Irregular flashing of all available lights</p> <p>HELICOPTERS: DAY or NIGHT - Irregular flashing of all available lights.</p>	In distress	DAY or NIGHT - Use Series 2 signals prescribed for	Understood

VISUAL FLIGHT RULES

6.52 Visual Meteorological Conditions (VMC). With the exception of special VFR (SVFR - see paragraph 6.7), VFR is only permitted in VMC (see 6.5). If a flight is operated under VFR and the meteorological condition deteriorate such that it becomes impossible to continue in VMC the pilot must either:

- Land whilst able to maintain flight in VMC; or
- Change the route of the flight to maintain flight in VMC; or
- File an IFR flight plan and continue under IFR; or
- If within a CTR, request a SVFR clearance.

6.53 Take off Conditions. Unless authorised by ATC, VFR flights are not to take-off or land at an aerodrome in a CTR, or enter the ATZ or traffic pattern:

- When the cloud ceiling (see definition) is less than 450m (1500ft) or
- When ground visibility (see definition) is less than 5km

6.54 Prohibition of VFR flight. Between sunset and sunrise, or during any other period as may be specified by the ATS authority, VFR flights are to be operated in accordance with the conditions required by such authority.

- VFR flights require an ATC clearance to operate:
 - Above FL200.
 - At transonic or supersonic speeds.
- VFR flight is not permitted above FL285 where RVSM is applied.
- Except when taking off and landing (or when specially approved by the authority i.e. air displays etc...), VFR flight is not allowed:
 - Over the congested areas of cities, towns or settlements, or over an open air assembly of persons, at a height less than 300m (1000ft) above the highest obstacle within a radius of 600m from the aircraft.
 - At a height not less than 150m (500ft) above the surface (ground or water).

6.55 VFR Flight Levels. In level cruising flight above the transition altitude (normally 3000ft AGL), VFR flight is to be conducted at a VFR flight level appropriate to the magnetic track of the aircraft in accordance with the semi-circular rule defined in paragraph 6.68. When operating as a controlled VFR flight within controlled airspace (CAS), the FL or altitude, will be specified by ATC in the ATC clearance for that flight. VFR flights are to comply with ATC instructions:

- When operating in class B, C or D airspace (in class A, VFR flight is not permitted)
- When forming part of aerodrome traffic at controlled aerodromes, or
- When operating as special VFR flights

6.56 VFR Flight Plan. A VFR flight plan is to be filed before operating a VFR flight as a controlled flight. To indicate that the flight will be operated under VFR, the letter “V” is placed in item 8 of the flight plan form. If a flight is to commence under VFR and at some point en-route change to IFR, the letter “Z” is placed in field 8 (V → I = Z). Where the PIC of a VFR flight wishes to change to IFR:

- If a VFR flight plan was submitted, the PIC is to communicate the necessary changes to be effected to the current flight plan, or
- He/she is to submit an IFR flight plan and obtain a clearance prior to proceeding under IFR when in controlled airspace.

6.57 EET. The time put in field 16 of a VFR flight plan is the time from take off until overhead the destination aerodrome.

6.58 Communications. Controlled VFR flights and VFR flights into airspace where the ATS authority considers it advisable are to maintain 2-way RTF communication with a controlling or monitoring ATSU and make position reports as necessary. In airspace classified as class E or G, VFR traffic may operate without two-way communications (non-radio).

INSTRUMENT FLIGHT RULES

6.60 IFR. For aircraft to be operated in IFR, i.e. rules not met conditions, (IMC exists when VMC does not!), the following rules are applicable. The rules are collectively known as the Instrument Flight rules (IFR). Annex 1 (Personnel Licensing - 2.1.7) states that where a licence is issued by a contracting state, it shall not permit the holder to act as PIC or co-pilot of an aeroplane under IFR unless the holder also holds a valid instrument rating (IR) appropriate to the aircraft category.

6.61 Aircraft Equipment. Aircraft are to be equipped with suitable instruments and with navigation equipment appropriate to the route to be flown. The necessary equipment is detailed in JAR OPS-1 and is covered in Operational Procedures lectures.

6.62 Minimum Levels. Except when necessary for take-off and landing, or where specially authorised by the appropriate ATS authority, an IFR flight shall be flown at a level which is not below the minimum flight altitude established by the state whose territory is being overflown, or where no such minimum altitude is specified:

- Over high terrain or mountainous areas (not defined further), the minimum level must be at least 600m (2000 ft) above the highest obstacle located within 8 km (5 nm) of the estimated position of the aircraft
- In areas other than in a. above, minimum level is to be 300 m (1000 ft) above the highest obstacle within 8 km (5 nm) of the estimated position of the aircraft.

6.63 IFR Flight Plans. An IFR flight plan is to include the letter I in item 8 of the flight plan form. If the intention is to change from IFR to VFR at some point during the flight the letter Y is to be inserted in item 8 (I → V = Y).

6.64 Changing from IFR to VFR. Where a pilot elects to change from IFR to VFR and the flight plan was **not** annotated Y in filed 8, the pilot is to notify the ATS authority that flight under IFR is cancelled using the phrase “cancelling my IFR flight” and then communicate the necessary changes to the current flight plan are to be passed. ATC will respond, “IFR cancelled at (time)”. When an IFR flight encounters VMC it shall not cancel IFR unless it is anticipated and intended that the flight will be continued for ‘a reasonable period’ of time in uninterrupted

VMC. In any event, a change of flight rules must only be at the request of the pilot.

6.65 EET. The time put in field 16 of an IFR flight plan is the time from take off until over the initial approach fix (IAF) for the instrument procedure at the destination aerodrome.

6.66 IFR within Controlled Airspace (CAS). IFR flights within CAS are to comply with instructions issued by the appropriate ATC unit. IFR flights in cruising flight shall be flown at a cruising level, or when authorised to employ cruise climb techniques, between two levels or above a level, selected from:

- The table of cruising levels (see 6.68 below)
- A modified table of cruising levels, if applicable, for flight above FL410 (see 6.68 below).

6.67 IFR outside Controlled Airspace (CAS). The following rules apply to IFR flights outside CAS:

- **Cruising Levels.** IFR flights outside CAS are to be flown at cruising level appropriate to the magnetic track of the aircraft (see 6.68 below).
- **Communications.** IFR flights operating outside CAS but within or into areas or along routes designated by the authority as those where the filing of a flight plan is required, are to establish communication and maintain a continuous listening watch with the ATS unit providing a flight information service (FIS).
- **Position Reports.** An IFR flight outside CAS and required to either submit a flight plan or maintain a listening watch with the unit providing FIS, is to make position reports. For flights operating off ATS routes (airways) or in a defined operating area, position reports are to be made at intervals of 1 hour after an initial report has been made 30 minutes after leaving CAS or after commencing the controlled flight. Where a position report is meaningless (prolonged controlled flight operations in a confined area) an 'operations normal' call is to be made at hourly intervals to prevent unnecessary activation of the alerting service. An example of an 'operations normal' call is:

"London Control this is GADRF operations normal at 1020, 2000ft and below. Will call again at 1120"

SEMI-CIRCULAR FLIGHT LEVEL RULES AND RVSM

6.68 Introduction. In order to apply vertical separation inside CAS, ATC will allocate specific FLs to individual aircraft which may, or may not, comply with the semi-circular rule. However, for planning purposes and outside of CAS, pilots should select the required cruising level (IFR or VFR) from the ICAO table of FLs. From the tables, the Semi-circular rules can be derived, which permit the selection of FLs in accordance with aircraft magnetic track. Tracks are specified as being either 'eastbound' or 'westbound'. Eastbound tracks are 000°M - 179°M inclusive, and westbound, 180°M - 359°M inclusive. Specific FLs are allocated to VFR and IFR traffic. IFR FLs are whole thousands of feet whereas VFR levels are whole thousands plus 500ft up to FL285. Eastbound levels are defined as 'odd' and westbound as 'even' from the first two digits of the FL number. Above 30 000ft, generally, the vertical separation is doubled and IFR levels are all odd, and VFR levels are even. A special system of FL allocation is applied where reduced vertical separation (RVSM) is applied

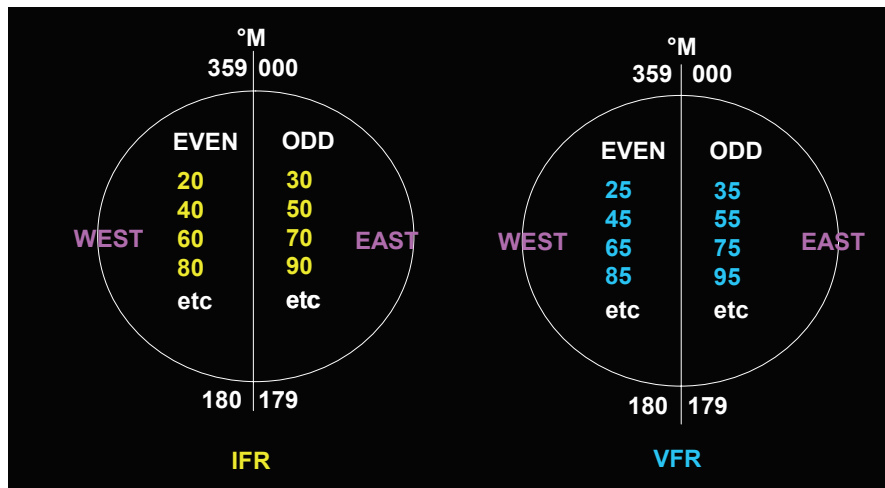

Figure 6.12: IFR and VFR flight levels up to and including FL290.

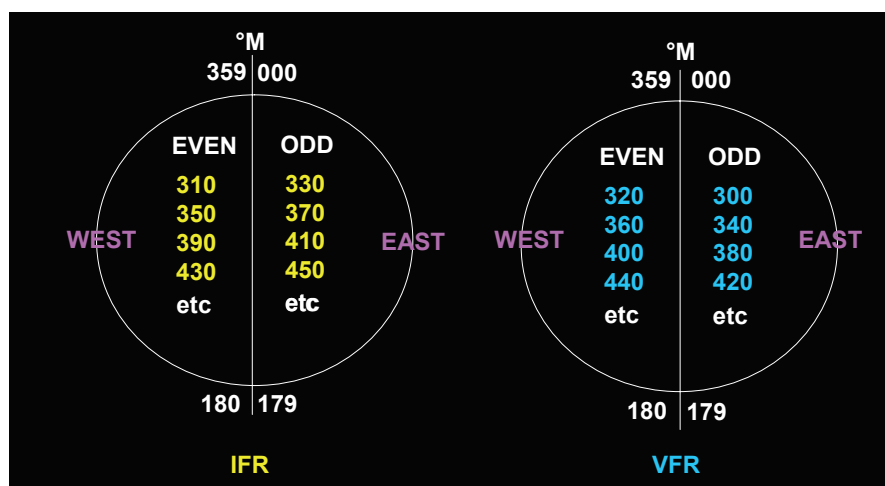

Figure 6.13: IFR and VFR flight levels above FL290.

6.69 RVSM. In order to make more FLs available to turbojet traffic in the cruise, a system has been adopted which prohibits VFR flight (thus making VFR levels available to IFR traffic). In order to achieve this, the separation between IFR levels between FL290 and FL410 inclusive is reduced from 2000ft to 1000ft. It is a requirement of aircraft using the RVSM system that they be fitted with A/TCAS and be approved by the airspace authority. Above FL410 the altimeter errors are considered too great to continue the 1000ft separation; however, the traffic density above FL410 is light enough for this not to be a problem.

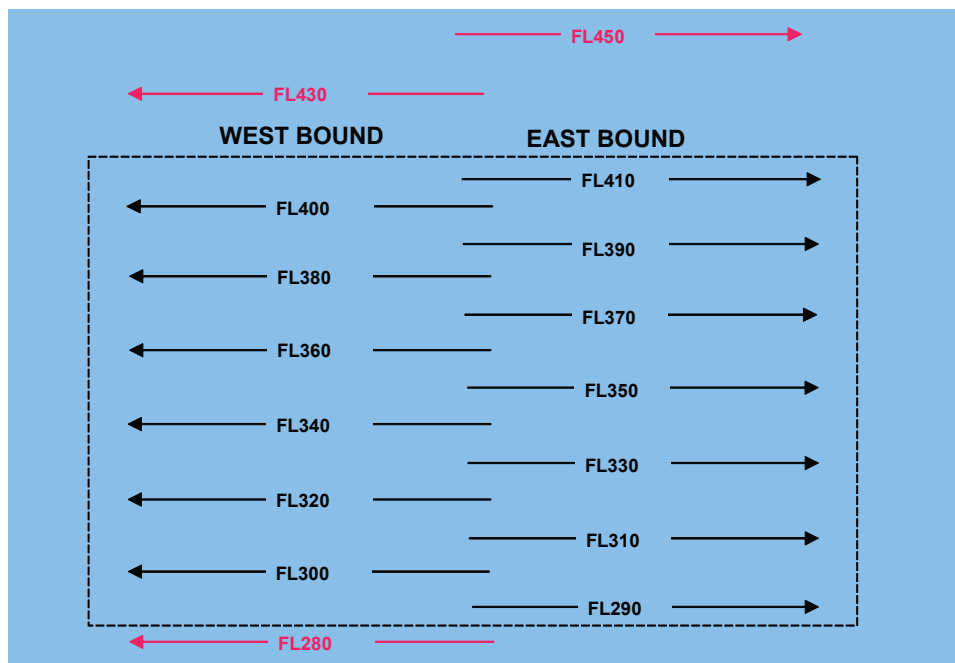

Figure 6.14: Reduced vertical separation minima.

SPECIAL VFR

6.70 History. With the introduction of airspace restrictions in the late 1960s, military aerodromes close to large international aerodromes, specifically Northolt in proximity to the rapidly expanding Heathrow, found that IFR procedures were mandatory in the new control zones when previously VFR procedures were generally accepted. In order to allow aeroplanes to fly into and out of Northolt (in the then Heathrow Special Rules Zone) a procedure based on a corridor in which visual navigation was required was set up. Providing the pilot could see the ground, he could navigate and provided he remained clear of cloud he could avoid collisions. A system of 'not quite' IMC or special VFR was invented. Until the late 1970s this was applied in what was known as the Northolt special VFR corridor. It was expanded to include the general aviation aerodrome at Denham and its obvious advantages for aeroplanes and pilots unable to comply with IFR were obvious. When the classes of airspace (A - G) were introduced, ICAO also adopted the special VFR as a procedure with appropriate international amendments.

6.71 SVFR. SVFR is defined by ICAO as a VFR flight cleared by ATC to operate within a CTR in meteorological conditions below VMC. It is only applicable to flights into, out of, or within a CTR. ICAO requires that the ground visibility within the CTR is not less than 1500m before a SVFR flight is permitted to enter the CTR to land, take off and depart, cross or operate locally within the CTR. More restrictively, JAR OPS-1 requires 3 000m visibility for a SVFR flight to be commenced.

DISTRESS AND URGENCY SIGNALS

6.72 Distress: Definition - An aircraft (or vessel) is in grave and imminent danger and requests immediate assistance.

- A distress message is preceded by the word MAYDAY repeated 3 times.
- Visual signals from an aircraft in distress may include
 - A succession of RED pyrotechnics
 - A RED parachute flare

6.73 Urgency. Definition - An aircraft has an urgent message to transmit concerning the safety of a ship, aircraft, vehicle or other property of a person on board or within sight. An Urgency message is preceded by the words PAN PAN repeated 3 times.

6.74 Non emergency situation. If an aircraft has a communications failure or a malfunction that makes it imperative that the aircraft is landed but the pilot doesn't require any other assistance, the pilot shall indicate the fact by repeatedly switching the landing lights (or any other light) on and off.

6.75 Emergency Frequencies. The following are dedicated radio frequencies used to communicate Distress, Urgency and Safety messages. You are required to know these.

- VHF 121.500Mhz (Aeronautical mobile emergency VHF)
- UHF 243.000Mhz (Aeronautical mobile emergency UHF)
- HF 2182kHz (International maritime distress and calling HF)
- SARTSAT 406 MHz (SAR beacon frequency (also radiates on 121.5))

6.76 Search and Rescue. SAR procedures and the requirements of the SAR service are covered in chapter 18 of the notes. There are discrete frequencies allocated to SAR operations (VHF, UHF and HF). You are not required to remember these, but if called on to assist in SAR operations you will be required to use the frequencies under direction.

6.77 SSR. Secondary Surveillance Radar is covered in chapter 13 of this book and in depth in Radio Navigation. There are however, certain reserved codes (squawks) that have specific meaning, which you are required to know. At all times you should transmit the altimeter function (mode charley) in addition to the reserved codes. The reserved transponder codes are:

- **Mode A code 7700.** This is the civil emergency code and is used unless a specific identification code has been allocated by a radar controller and the aircraft has been identified.
- **Mode A code 7600.** This is the squawk to indicate radio failure and should be used at all times when a failure occurs regardless of the ATC service being provided.
- **Mode A code 7500.** This code indicates unlawful interference. Its use does not imply that the fact is being generally advertised. Discretion and confidentiality will be preserved by the ATC authority until the pilot mentions the fact by RTF. A pilot may prefer to use the 7700 squawk to indicate the severity of the situation.
- **Mode A code 7000.** This code indicates that the aircraft is operating in an area where a radar service is available from an ATCU but the aircraft is not in receipt of the service. It implies that the aircraft is operating under VFR.

- **Mode A code 2000.** This code is used to indicate that an aircraft is entering an area where a radar service is available and will be requesting that service. Usually used by aircraft entering a domestic FIR from an Oceanic control area.
- **Mode A code 0000.** This code is reserved to indicate that the aircraft transponder is in some manner unserviceable or inaccurate.

RESTRICTED, PROHIBITED OR DANGER AREAS

6.78 Specification. Each state has the right to restrict or prohibit flight in territorial airspace for reasons of security or safety. Such areas are known as danger areas (indicated by the letter **D**), restricted areas (indicated by the letter **R**) or prohibited areas (indicated by the letter **P**) and are detailed in the AIP. These are designated by a code identifying the area and showing the altitude (usually in 1000s of ft) to which the area extends. Areas may be either permanently active (PERM) or activated by NOTAM. The area designator (for instance - **D001**) cannot be re-used for a period of not less than 12 months after the closure of the previously designated area. This allows for a full reprint of the 1/2 million topographical charts so that no confusion can exist.

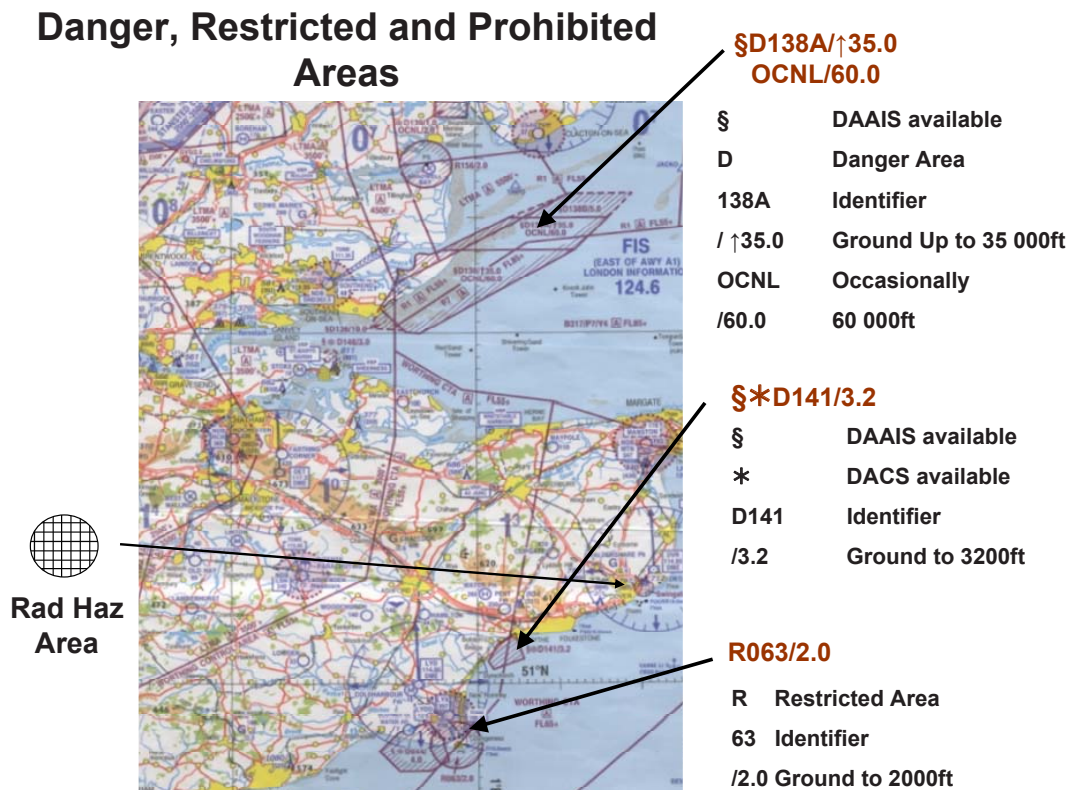

Figure 6.15:

6.79 Visual Warning of Incursion. By day and night; a series of projectiles discharged from the ground at intervals of 10 secs, each showing on bursting red and green lights or stars, are used to warn aircraft that they are flying in or about to enter restricted, prohibited or danger areas.

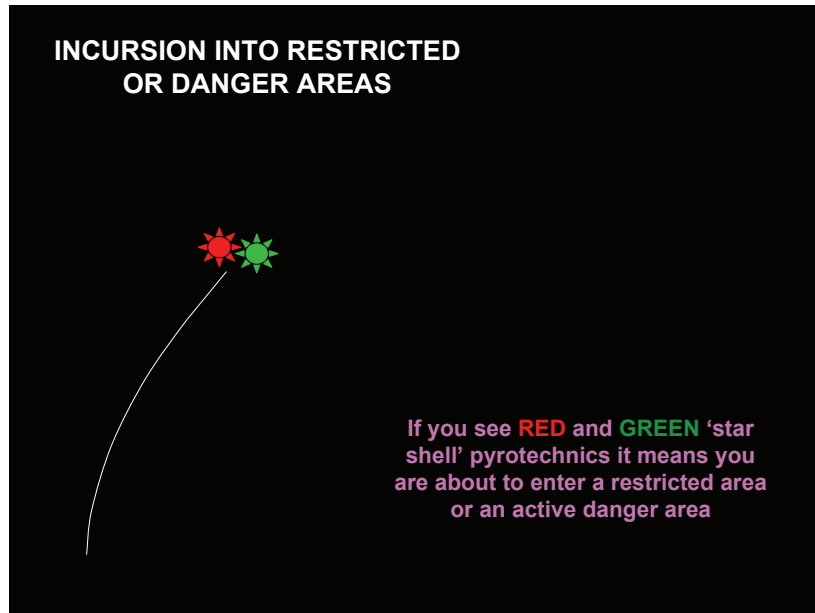

Figure 6.16:

SIGNALS FOR AERODROME TRAFFIC

6.80 Non-Radio Traffic. Non radio traffic on or in the vicinity of an aerodrome is to keep a good look out for visual signals from ATC. Aeroplanes with radios are also to comply with instructions given visually. The lamp used by ATC to communicate (Aldis lamp) is directional with a narrow beam. If you see a signal light from the tower, you must assume that it is meant for you.

6.81 Visual Signals. The following table gives the light and pyrotechnic signals used from ground to air:

Light	From Aerodrome Control to:	
	Aircraft in Flight	Aircraft on the Ground
Steady Green	Clear to land	Cleared for take-off
Steady Red	Give way to other aircraft and continue circling	Stop
Green flashes	Return for landing and await landing clearance	Cleared to taxi
Red flashes	Aerodrome unsafe, do not land	Taxi clear of the landing area
White flashes	Land at this aerodrome after receiving clearance to land and then proceed to the apron	Return to the starting point on the aerodrome
Red pyrotechnic (flare)	Notwithstanding any previous instructions, do not land for the time being	

Figure 6.17:

6.82 Acknowledgement by Aircraft. To acknowledge receipt of a signal as per table 6.81, an aircraft may make the following:

- When in flight:
 - During the hours of daylight, by rocking the aircraft’s wings
 - During the hours of darkness, by flashing on and off twice the aircraft’s landing lights or, if not so equipped, by switching on and off the navigation lights twice.
- When on the ground:
 - During the hours of daylight by moving the aircraft’s rudder or ailerons;
 - During the hours of darkness by flashing on and off twice the aircraft’s landing lights or, if not so equipped, by switching on and off the navigation lights twice.

6.83 Visual Ground Signals. The following signals may be shown on an aerodrome, either in the signals square or at other locations on the apron or movement area. A signal square is usually located in front (aerodrome side) of a control tower (visual control room) and is to be visible from the air anywhere in the vicinity of the aerodrome. The purpose is to convey essential information to pilots unable to communicate by radio. Other signals, applicable to non-radio traffic on the ground are displayed from a signals mast (also in front of the control tower) or by means of indicator boards (information signs) located on or adjacent to the control tower. The absence of a signal square indicates that the aerodrome is not to be used by non-radio traffic. This is the case at Oxford, where due high traffic density and trainee pilots in the circuit, non-radio traffic is considered hazardous.

Note: The use of any signal by any person shall only have the meaning assigned to it under the rule.

6.84 Signals in the Signals Area. The following signals are displayed on aerodromes to pass information to non radio aircraft. In the examination, you will be expected to interpret the meaning of a signal from a written description of the sign:

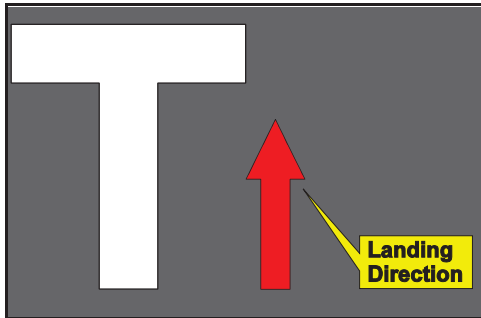

A white "T" signifies that takeoffs and landings shall be in the direction of the shaft of the "T" (as indicated by the arrow).

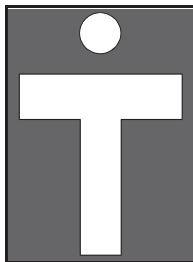

A white disc added to the "T", means that take-off and landing direction do not necessarily coincide.



A white dumb-bell indicates that aircraft movement on the ground is confined to paved, metalled or similar hardened surfaces.



A white dumb-bell with black stripes signifies that take offs and landings are to be on a runway, but movement on the ground is not confined to pavements.

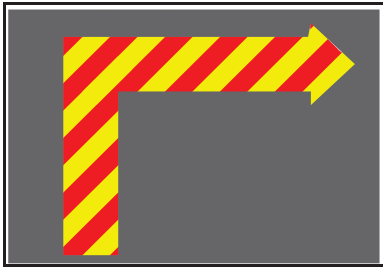

A red and yellow striped arrow signifies that a right hand circuit is in force.



A red panel with a yellow diagonal stripe signifies that the manoeuvring area is poor and pilots must exercise special care.



A red panel with a yellow cross signifies that the aerodrome is unfit for aircraft movements, and landings are prohibited.

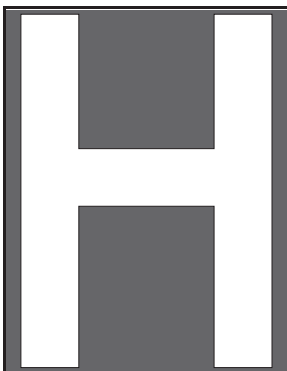

A white "H" signifies that helicopters shall take-off and land only within the area designated by the marking.



A red 'L' over a dumb-bell means that light aircraft are permitted to take off and land either on a runway or on the area designated.

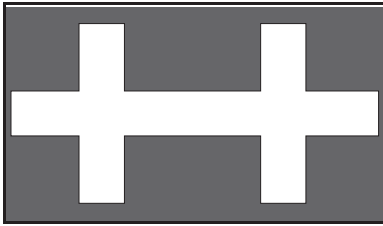

A white double cross means that glider flying is in progress.



Two or more white crosses indicate that the section of the runway or taxiway (yellow) is unfit for aircraft movement. Orange and white boundary markers will delineate the limit of the unusable ground or runway

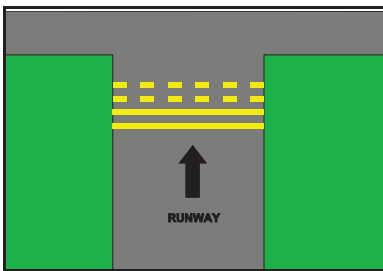

Two yellow broken lines and two continuous lines signify the holding point closest to the runway. Outside of the notified hours for ATC, this is the closet point an aircraft or vehicle can approach to the runway for the purpose of giving way to aircraft landing or taking off. This is a 'pattern A' marking

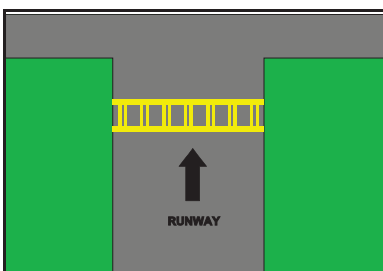

A yellow 'ladder' marking across the taxiway indicates a holding point other than the closest to the runway. Outside ATC hours it can be ignored. This is a 'pattern B' marking



A black letter "C" on a yellow background indicates where a visiting pilot should report on arrival.

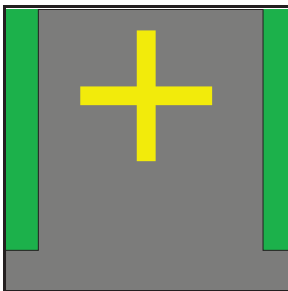

A yellow St George's cross indicates the position on the manoeuvring area where tow ropes and banner can be dropped.

6.85 **Signals Mast.** The following signals are flown from the signals mast:

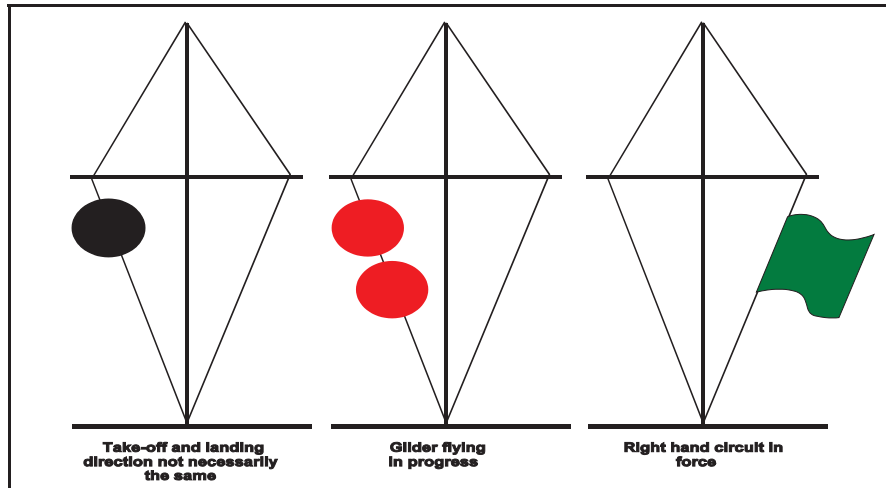

6.86 **QDM Boards.** A yellow board with two black numbers on, is situated on the tower, and indicates the runway direction in use (QDM).

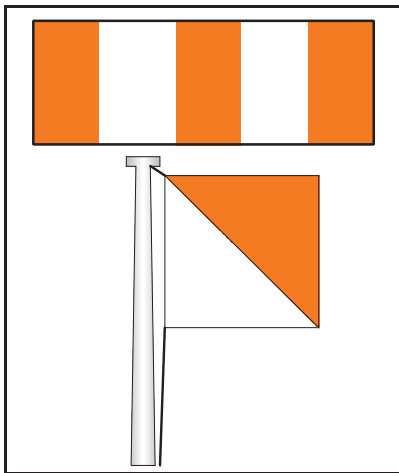

6.87 **Boundary markers.** Orange and white striped markers indicate the boundary of the manoeuvring area where it is not clearly defined.

6.88 **Wind Sleeve.** A wind sleeve (windsock) indicates the wind direction and speed.
 (Large = 40kt; medium = 30kt; small = 20kt) Max wind speed (i.e. 40kt) Half wind speed (i.e. 20kt) Calm

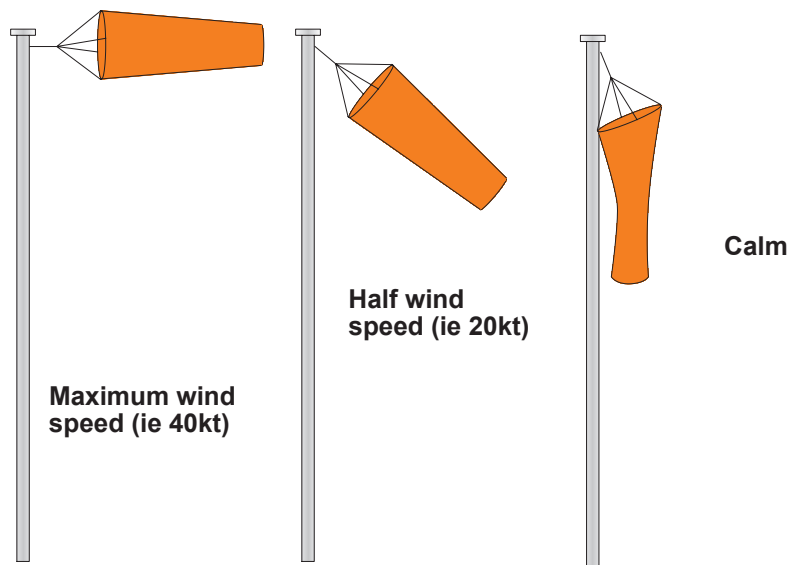

6.89 Marshalling Signals. The student should be familiar with the following marshalling signals:

Intention	Signal
Proceed Under further guidance	R or L arm down, other arm moved across the body and extended to indicate position of other marshaller
This bay	Arms placed above the head in a vertical position
Move ahead	Arms repeated moved upward and backward, beckoning onward
Turn LEFT	R arm down, L arm repeatedly moved upward and backward. The speed of the arm movement indicates the rate of turn.
Turn RIGHT	L arm down, R arm repeatedly moved upward and backward. The speed of the arm movement indicates the rate of turn.
Stop	Arms repeatedly crossed above the head. The speed of the movement indicates the urgency to stop.
Engage brakes	Raise arm and hand with fingers extended, horizontally in front of body, then clench fist. (Not used at night)
Release brakes	Raise arm and hand with fist clenched, horizontally in front of body, then extend fingers. (Not used at night)
Chocks Inserted	Arms extended, palms inwards, then swung from the extended position inwards
Chocks removed	Arms down, palms outwards, then swung outwards
Start Engine(s)	A circular motion of the R hand at head level, with L arm pointing to the appropriate engine
Cut Engine(s)	Either arm and hand placed level with the chest, then moved laterally with the palm downwards
Slow down	Arms placed down with palms towards the ground, then moved up and down several times
Slow down engine on indicated side	Arms placed down, with palms towards the ground, then either arm moved up and down several times
Move back	Arms placed down, palms facing forwards, then repeatedly swept up and down to shoulder level
Intention	Signal
Turn tail to right when backing	Point L arm down, move R arm down from overhead vertical position to horizontal forward position, repeating R arm movement
Turn tail to left when backing	Point R arm down, move L arm down from overhead vertical position to horizontal forward position, repeating L arm movement
All clear	R arm raised at the elbow, with the palm facing forward
Brakes engaged	Raise R arm and hand with fingers extended horizontally in front of face, then clench fist
Brakes released	Raise arm with fist clenched horizontally in front of face, then extend fingers

Insert chocks	Arms extended palm facing outwards, move hands inwards to cross in front of face
Remove chocks	hands crossed in front of face, palms outwards, move arms outwards
Ready to start engines	Raise the number of fingers on one hand to indicate engine number of engine to be started.*

6.90 Flight Deck Signals. The signals made, by a pilot, from the flight deck have the following meaning:

Intention	Signal	CAP 673 Ref:
Brakes engaged	Raise R arm and hand with fingers extended horizontally in front of the face then clench fist	Sect 6 Table F (a)
Brakes released	Raise R arm and hand with fist clenched horizontally in front of the face then extend fingers	Sect 6 Table F (b)
Insert chocks	Arms extended palm facing outwards, move hands inwards to cross in front of the face	Sect 6 Table F (c)
Remove chocks	Hands crossed in front of the face, palms outwards, move arms outwards	Sect 6 Table F (d)
Ready to start engines	Raise the number of fingers of one hand to indicate engine number of the engine to be started *	Sect 6 Table F (e)

*Note ** Engines are numbered:

1	Port (left) outer
2	Port (left) inner
3	Starboard (right) inner
4	Starboard (right) outer

QUESTIONS

1. When, in airspace where VFR is permitted, the PIC of an IFR flight wishes to continue the flight in accordance with VFR until destination:
 1. the pilot must inform the control unit of his intention using the expression "cancelling my IFR flight".
 2. the pilot must request and obtain clearance to continue under VFR.
 3. the pilot must communicate the necessary changes to the current flight plan.
 4. the flight plan automatically becomes a VFR flight.

Which of the following combinations is correct?

- a. 2 and 3.
 - b. 2 and 4.
 - c. 1 and 3.
 - d. 1 and 4.
2. An aircraft flying in the visual circuit at an aerodrome sees a series of red flashes from the control tower. What does this mean?
 - a. Do not land.
 - b. Do not land because the aerodrome is unusable.
 - c. Give way to other aircraft.
 - d. Return for landing and await clearance to land.
 3. An aircraft has flight visibility of 3km, and is heading 355° T in an area where the variation is 6° west. There is no appreciable wind. Which of the following is the appropriate flight level?
 - a. FL60.
 - b. FL65.
 - c. FL70.
 - d. FL75.
 4. An aircraft is converging from the left. Which light will you see first?
 - a. Red.
 - b. Green.
 - c. Blue.
 - d. White.
 5. What letter goes in item 8 of a flight plan for a flight starting under IFR then changing to VFR?
 - a. Z
 - b. Y
 - c. I
 - d. V
 6. What are the VMC limits for class B airspace?
 - a. 8 km flight visibility, clear of cloud and in sight of the surface.
 - b. 8km flight visibility, 1,000 ft vertically and 1500m horizontally from cloud.
 - c. 5km flight visibility, 1,000 ft vertically and 1500 m horizontally from cloud.
 - d. The same as class D.

7. When is a flight plan required?
 - a. For IFR flight in advisory airspace.
 - b. For all IFR flights.
 - c. For all flights in controlled airspace.
 - d. For all VFR and SVFR flights in controlled airspace.

 8. Whilst airborne in the vicinity of the aerodrome, you see a flashing green light from the Tower. What does this mean?
 - a. Cleared to land.
 - b. Return for landing and await clearance to land.
 - c. Give way to other landing aircraft.
 - d. Land at this aerodrome after receiving clearance to land and proceed to the apron.

 9. You see a double white cross in a signal square, what does this mean?
 - a. Glider flying in progress.
 - b. Tow ropes and banners may be dropped.
 - c. Runway unfit for aircraft movement.
 - d. Aerodrome unfit for aircraft movement.

 10. You are taxiing on the manoeuvring area of an aerodrome and see a flashing green light from the tower. What does it mean?
 - a. Return to start point.
 - b. Clear to taxi.
 - c. Clear to take off.
 - d. Stop.

 11. You have been intercepted in the airspace of a foreign contracting state. What is the signal for 'clear to proceed' from the intercepting aircraft?
 - a. Rocking wings.
 - b. Flashing lights.
 - c. Cut across track.
 - d. Breaking turn up and left.

 12. Which has priority to land?
 - a. A hospital flight.
 - b. An emergency.
 - c. A military flight.
 - d. A VIP flight.

 13. What does a double horizontal white cross on an aerodrome indicate?
 - a. Glider flying in progress.
 - b. Runway unfit for use.
 - c. Light aircraft may taxi on the grass.
 - d. Runway to be used for take off but aircraft may taxi on the grass.
-

14. Which of these is not a distress frequency?
1. 121.5 MHz
 2. 2182 KHz
 3. 243.0 KHz
 4. 2430 KHz
- a. 4 only.
 - b. 2 only.
 - c. 2, 3 and 4.
 - d. 3 and 4.
15. If you are intercepted by another aircraft, what do you set on the SSR transponder?
- a. A/2000 + C.
 - b. A/7500 + C.
 - c. A/7600 + C.
 - d. A/7700 + C.
16. You are taxiing an aircraft on the ground at an aerodrome and you see a flashing red light from the tower. What does it mean?
- a. Stop.
 - b. Taxi clear of the landing area.
 - c. Give way to approaching aircraft.
 - d. You are not clear to take off.
17. Aircraft A is a VFR flight operating in a CTR under an ATC clearance. Aircraft B is entering the CTR without clearance. As they converge, which one has the right of way?
- a. B has right of way regardless of aircraft type and position.
 - b. A has right of way regardless of aircraft type and position.
 - c. A has right of way if B is on the right.
 - d. B has right of way if A is on the left.
18. What minimum ground visibility is required to enable a SVFR flight to take off from an aerodrome in a CTR?
- a. 1000m
 - b. 1500m
 - c. 2000m
 - d. 3000m
19. If a pilot wishes to cancel an IFR flight plan and proceed under VFR in VMC, he/she must inform ATC and include the phrase:
- a. "cancelling my flight plan".
 - b. "cancelling my flight".
 - c. "cancelling my IFR flight".
 - d. "cancelling my IMC flight plan".

20. What signal from a marshaller to a pilot indicates “apply brakes”?
- Waving the arms across the face.
 - Drawing the palm across the throat.
 - Clenching a raised fist.
 - Holding both arms up with palms facing forward.
21. ATC has given you the transponder code of A/5320. In case of a radio failure in flight you must squawk:
- A/7600 + Mode C.
 - A/0020 + Mode C.
 - A/5300 + Mode C.
 - A/7620 + Mode C.
22. For a controlled flight, a flight plan must be filed before departure at least:
- 60 minutes before off-block time.
 - 60 minutes before departure.
 - 30 minutes before departure.
 - 30 minutes before off-block time.
23. Which Mode A code must be used to make sure that your aircraft is recognised as an aircraft in distress?
- Code 7500
 - Code 7700
 - Code 7000
 - Code 7600
24. An aircraft which is intercepted by another aircraft must immediately try to contact the intercepting aircraft on the following frequencies:
- 121.5 MHz and/or 243.0 MHz.
 - 121.5 MHz and/or 282.8 MHz.
 - 121.5 MHz and/or 125.5 MHz.
 - 243.0 MHz and/or 125.5 MHz.
25. Your aircraft is intercepted by a military aircraft. Instructions given by this aircraft do not comply with ATC instructions. You should:
- select code 7500 A on your transponder.
 - ask ATC for different instructions.
 - comply with instructions given by the intercepting aircraft.
 - comply with ATC instructions.
26. A pilot crosses his/her hands in front of the face, palms outwards and then moves the arms outwards. What does this signal indicate?
- Clear to move forward.
 - Brakes off.
 - Remove chocks.
 - Clear to close all engines.

27. A red flare fired at a flying aircraft means:
- do not land, the aerodrome is unfit.
 - notwithstanding any previous instructions, do not land for the time being.
 - return to the aerodrome for landing.
 - give way to another aircraft and continue to circle.
28. In order to avoid confusion, the identification numbers given to each prohibited, restricted and danger area shall not be re-used for a period of:
- at least 12 months after the cancellation of the area referred to.
 - at least 6 months after the cancellation of the area referred to.
 - at least 3 months after the cancellation of the area referred to.
 - at least 2 months after the cancellation of the area referred to.
29. When an aircraft has been subjected to unlawful interference, the pilot may wish to indicate the fact by squawking which SSR code:
- 7500
 - 7700
 - 7600
 - 7000
30. Which of the following procedures would a pilot follow in the event of communications failure whilst under IFR in VMC?
- Return to the aerodrome of departure.
 - Continue the flight whilst maintaining VMC and land as soon as possible.
 - Continue the flight at the assigned level and route and start the approach at the stated ETA.
 - Maintain the assigned level and route and land at the nearest aerodrome that is reporting VMC.
31. If so equipped, when should an aircraft display the anti collision light?
- Only at night in flight, but not on the ground if being towed.
 - Whilst taxiing but not whilst being towed.
 - Only at night with engines running.
 - At all times on the ground when the engines are running.
32. The 'estimated elapsed time' in field 16 of a flight plan for a VFR flight is the estimated time:
- From which the aircraft first moves under its own power until it finally comes to rest after landing.
 - From brakes release at take-off until landing.
 - At cruising level taking into account temperature and pressure for that day.
 - From take-off until overhead the destination aerodrome.
33. What is the minimum vertical separation between IFR flights flying in the same direction below FL 290?
- 500 ft
 - 1,000 ft
 - 2,000 ft
 - 4,000 ft

34. The cruising speed entered in item 15 of a flight plan is:
- TAS.
 - TAS or Mach No.
 - IAS or TAS.
 - TAS at 65% engine power.
35. What action is required by the pilot of an aircraft flying in the vicinity of an aerodrome to indicate that the aircraft is experiencing radio failure or another difficulty that requires immediate landing but no other assistance?
- The repeated switching on and off of the landing lights.
 - Switching the landing lights on and off three times.
 - Switching the landing lights on and off four times.
 - Switching the navigation lights on and off three times.
36. A position report shall contain the following information in the order listed?
- Aircraft identification, position, time, true airspeed, flight level or altitude, next position and time over.
 - Aircraft identification, position, time, flight level or altitude, next position and time over.
 - Aircraft identification, position, time, flight level or altitude, next position and time over, ensuing position.
 - Aircraft identification, position, flight level or altitude, next position and time over, ensuing position and time over.
37. For an IFR flight, the EET stated is the estimated time at which the aircraft:
- will arrive overhead the initial approach fix.
 - will land.
 - will be overhead the destination aerodrome.
 - will leave the initial approach fix to commence the instrument procedure.
38. A DISTRESS message differs from an URGENCY message because:
- there is grave and imminent danger which requires immediate assistance.
 - the aeroplane has suffered damage that endangers the ability to fly.
 - the aeroplane will not be able to reach a suitable aerodrome.
 - the situation concerns the safety of passengers on board or within sight.
39. If radio contact with an intercepting aircraft is established but not in a common language, what would the pilot of an intercepted aircraft say, if he/she is unable to comply with the instruction from the interceptor?
- "KAN NOTT KOMPLY"
 - "UNN-ABOL TOO KOMPLY"
 - "NOTT POSS ABOL"
 - "KANN NOTT"

40. Which of the following flight has the highest priority to land?
- VIP flight.
 - Hospital flight.
 - Emergency aircraft.
 - Military aircraft.
41. What letter is put in item 8 of a flight plan to indicate that a flight is to begin under IFR and finish under VFR?
- Y
 - I
 - V
 - Z
42. A white dumb-bell with black perpendicular bars indicates that:
- glider flying is being conducted outside the landing area.
 - landing and take-off is restricted to the runways but taxiing is not confined to the pavement areas.
 - this aerodrome is using parallel runways.
 - taxiing is confined to the taxiways.
43. If an ATC clearance is not suitable, the PIC may:
- offer ATC an acceptable alternative.
 - request and if practicable accept an amended clearance.
 - demand an alternative clearance and ATC must comply.
 - decline the clearance on the grounds that it is not in accordance with the filed flight plan.
44. What letter is put in item 8 of a flight plan to indicate that a flight is to begin under VFR and finish under IFR?
- Y
 - I
 - V
 - Z
45. Who has final authority as to the disposition of an aircraft during flight time?
- The owner.
 - The Operator.
 - The Commander.
 - The ATC controller.
46. The vertical separation minima for IFR flights in CAS applied by ATC above FL290 is:
- 500 ft.
 - 1,000 ft.
 - 2,000 ft.
 - 1,000 ft if RVSM is applied otherwise 2,000 ft.

47. Unless authorised by ATC, a VFR flight is not permitted to take-off from an aerodrome within a CTR when:
- cloud ceiling is less than 1,000 ft and ground visibility is less than 5km.
 - cloud ceiling is less than 1,500 ft and ground visibility is less than 5km.
 - cloud ceiling is less than 1,000 ft and ground visibility is less than 8km.
 - cloud ceiling is less than 1,500 ft and ground visibility is less than 8km.
48. An aircraft is flying over the sea between 4500ft and 9000ft AMSL and outside CAS. To continue under VFR the meteorological conditions must remain:
- 2,000 ft horizontally and 1,000 ft vertically from cloud with visibility of 8km.
 - 1500m horizontally and 1,000 ft vertically from cloud with visibility of 5km.
 - 1500m horizontally and 1000m vertically from cloud with visibility of 5km.
 - clear of cloud and in sight of the surface, with visibility of 5km.
49. A change in flight rules from IFR to VFR will only take place:
- when initiated by the PIC.
 - when ordered by ATC.
 - at a point specified by the operator.
 - when the aircraft leaves CAS in VMC.
50. An aircraft is overtaking another aircraft if it is closing to the other aircraft from behind in a sector:
- 50° either side of the longitudinal axis.
 - 60° either side of the longitudinal axis.
 - 70° either side of the longitudinal axis.
 - 80° either side of the longitudinal axis.

ANSWERS

Question	Answer	Reference	Question	Answer	Reference
1.	C	6.64	26.	C	6.9
2.	B	6.81	27.	B	6.81
3.	C	6.68	28.	A	6.78
4.	B	6.22	29.	A	6.77
5.	B	6.63	30.	B	6.41
6.	D	6.5	31.	D	6.26
7.	A	6.30	32.	D	6.58
8.	B	6.81	33.	C	6.68
9.	A	6.84	34.	B	6.3
10.	B	6.81	35.	A	6.74
11.	D	6.51	36.	C	6.37
12.	B	6.18	37.	A	6.65
13.	A	6.84	38.	A	6.72
14.	D	6.75	39.	D	6.50
15.	D	6.48	40.	C	6.18
16.	B	6.81	41.	A	6.64
17.	D	6.15	42.	B	6.84
18.	B	6.71	43.	B	6.33
19.	C	6.64	44.	D	6.57
20.	C	6.89	45.	C	6.9
21.	A	6.42 / 6.17	46.	D	6.68
22.	B	6.3	47.	B	6.54
23.	B	6.77	48.	B	6.5
24.	A	6.48	49.	A	6.64
25.	C	6.49	50.	C	6.16

CHAPTER SEVEN

INSTRUMENT PROCEDURES - DEPARTURES

Contents

INSTRUMENT PROCEDURES133
PANS OPS.135
INSTRUMENT DEPARTURE PROCEDURES135
QUESTIONS142
ANSWERS144

INSTRUMENT PROCEDURES

7.1 General Introduction. In order to permit all weather operation (low visibility take-off and landing) procedures must be established to provide track guidance and terrain avoidance for aircraft departing, and track guidance, terrain clearance and where special equipment is used, vertical displacement guidance for aircraft arriving at aerodromes. Low visibility operations (ICAO) are defined as take-off and landing operations with RVR less than 800m. Remember, the minima for take off from an aerodrome in a CTR is ground visibility not less than 5 km and cloud ceiling not less than 1500ft. The criteria for the type of procedure to be employed are defined in terms of RVR and the limit to which a pilot is permitted to descend (DA/H or MDA/H). Clearly, obstacle avoidance during the procedure is of paramount importance. The fundamental assumption is that an instrument procedure (departure or arrival) will only be flown in conditions less than VMC. In this case, arrivals and departures from controlled aerodromes will be flown under IFR and hence subject to ATC. Therefore, prior to commencing any instrument procedure, an ATC clearance must be obtained. Procedures for departure and arrival are published and you are required to have the necessary plates (printed representations of the procedures) available on the flight deck. If you are required by ATC to divert to an aerodrome with which you are not familiar and do not have the plates, ATC will read the procedure, including the loss of communications and missed approach procedures, to you. Initially we will look at instrument departure procedures. The following abbreviations are required knowledge:

7.2 Abbreviations

C/L	Centre line	MSA	Minimum Sector Altitude
DA/H	Decision altitude/height	NOZ	Normal operating zone
DER	Departure end of runway	NTZ	No transgression zone
DME	Distance measuring equipment	OIS	Obstacle identification surface
DR	Dead reckoning	PDG	Procedure design gradient
FAF	Final Approach Fix	SID	Standard Instrument Departure
FAP	Final Approach Point	STAR	Standard Arrival Route
IAF	Initial Approach Fix	TAA	Terminal Approach Altitude
IF	Intermediate Fix	TP	Turning point
MAPt	Missed Approach Point	VM(C)	Visual Manoeuvring Circling
MDA/H	Minimum descent altitude/	VM(C)A	Visual Manoeuvring Circling Area

7.3 Obstacle Clearance. It is implied that any procedure developed will not require the aeroplane to fly dangerously close to obstacles at any point during the procedure. Clearance from obstacles can be obtained by lateral clearance and vertical clearance. By requiring a pilot to fly the track accurately (within tolerances accepted) the aircraft can be guided over a surveyed flight path within the bounds of which, all obstacles can be determined and assessed. Obviously, the area surveyed must have finite limits. It is, however, not acceptable for, say, an area 5 nm wide to be surveyed and then permit aircraft to fly within guidance tolerance, 2.5 nm either side of the desired track. The extremities of the surveyed area must gradually permit higher obstacles until at the limit of reasonable expectations of accuracy (guidance tolerance - both equipment and flight technical), the guaranteed clearance is reduced to zero. This assessment is known as creation of MOC (minimum obstacle clearance areas). MOC is discussed later in this chapter. Obstacle clearance could be provided by assessing the highest obstacle to be flown over and by applying a safety margin to the obstacle height. An obstacle clearance height or altitude (OCA/H) can thus be obtained. This is the method of obtaining MSA and with refinements, minimum descent height/altitude (MDA/H) for non precision procedures. As precision procedures provide height guidance, an obstacle 1000 ft high at 10 nm from the threshold is not as significant as an obstacle 150 ft high 1 nm from the threshold (assuming a 300 ft per mile glide slope). For precision systems, OCA/H is 'range from threshold' dependant. It should therefore be obvious that OCA/H for precision procedures are less than OCH/A for non precision. It must be stressed that, from an operational point of view, the obstacle clearance applied in the development of each instrument approach procedure is considered to be the minimum required for an acceptable level of safety in operations. If you have your own aeroplane and it is not used for commercial air transport, you may operate to the published OCA/H limits. Operators apply higher criteria resulting in aerodrome operating minima for commercial air transport.

Obstacle Clearance

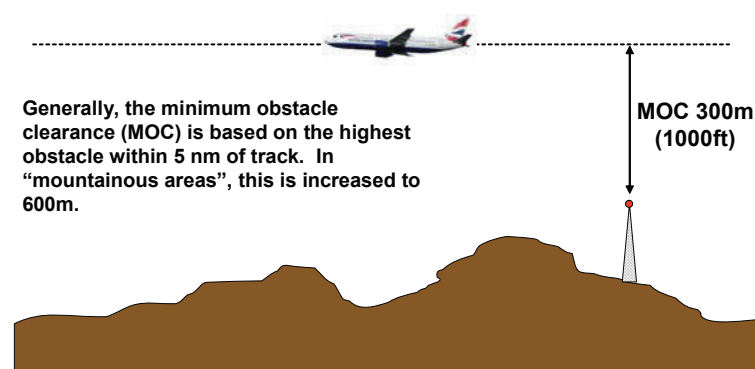

Figure 7.1:

Obstacle Clearance

For an instrument procedure, the procedure must keep the aeroplane clear of all obstacles by a minimum vertical interval.

The pilot must fly the aeroplane within the height tolerance specified by the instrument procedure designer

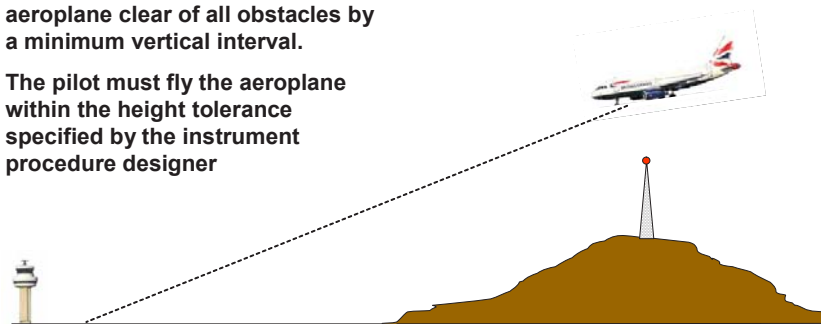

Figure 7.2:

PANS OPS

7.4 Document 8168. The ICAO document that specifies the recommendations for instrument procedures is PANS OPS. The term 'PANS-OPS' is commonly used to refer to the content of ICAO Doc 8168. The correct title of the document is "Procedures for Air Navigation Services - Aircraft Operations". The document is printed in two volumes; Vol 1 - Flight Procedures; Vol 2 - Construction of Visual and Instrument Flight Procedures. Volume 1 describes operational procedures recommended for the guidance of flight operations personnel and we shall limit our considerations of instrument procedures to the content of Vol 1. Vol 1 outlines the various parameters on which the criteria of Vol 2 are based. Volume 2 is intended for the guidance of procedures specialists and describes the essential areas and obstacle clearance requirements for the achievement of safe, regular instrument flight operations. Both volumes present coverage of operational practices that are beyond the scope of Standards and Recommended Practices (SARPS) but with respect to which, a measure of international uniformity is desirable. PANS OPS, in expanding the SARPS of Annex 6, considers both departure and arrival procedures and to a lesser extent, en-route procedures where obstacle clearance criteria should be taken into consideration.

INSTRUMENT DEPARTURE PROCEDURES

7.5 General Criteria. These procedures assume that all engines are operating. The design of an instrument departure procedure is, in general, dictated by the terrain surrounding the aerodrome, but may also be required to cater for ATC requirements (adjacent ATS routes, restricted, prohibited or danger areas and the proximity of other aerodromes). These factors in turn influence the type and position of navigation aids required to provide track guidance for the departure route. Airspace restrictions may also affect the position of navigation aids. From the pilot and operator point of view, the use of automatic take-off thrust control systems (ATTCS) and noise abatement procedures will need to be taken into account as well. Where no suitable navigation aid is available to provide specific track guidance, the criteria for omnidirectional (any direction) departures is applied. Wherever possible a straight departure will be specified, which is aligned with the runway. Where a departure route requires a turn of more than 15° to avoid an obstacle, a turning departure is constructed.

7.6 Requirements. Where instrument departures are required, a departure procedure will be established for each runway to be used, and will define the procedure for the various categories of aircraft based on an all engines running PDG of 3.3%, or an increased PDG if required to achieve minimum obstacle clearance. The procedures assume that pilots will compensate for wind effects (known or estimated) when flying departure routes which are expressed as tracks to be made good. If radar vectoring is applied, pilots are required to fly the vector headings and not make allowance for the wind.

7.7 Obstacle Clearance. As already stated, obstacle clearance is a primary safety consideration in instrument departure procedures. Unless otherwise stated a PDG of 3.3% is assumed. The PDG is made up of 2.5% gradient of obstacle identification surfaces or the gradient based on the most critical obstacle penetrating these surfaces (whichever is higher), and 0.8% increasing obstacle clearance. Gradients published will be specified to an altitude/height after which the minimum gradient of 3.3% is considered to exist. The final PDG continues until obstacle clearance is ensured for the next phase of flight (en-route; holding or approach). At this point the departure procedure ends and is marked by a significant point. The minimum obstacle clearance equals zero at the departure end of the runway (DER) and thereafter increases by 0.8% of the horizontal distance in the direction of flight, assuming maximum divergence of 15°. In the turn initiation area for a turning departure a minimum obstacle clearance of 90m (295 ft) is provided. Increased obstacle clearance will be provided in mountainous terrain. If DME is available, additional height/distance information is made available.

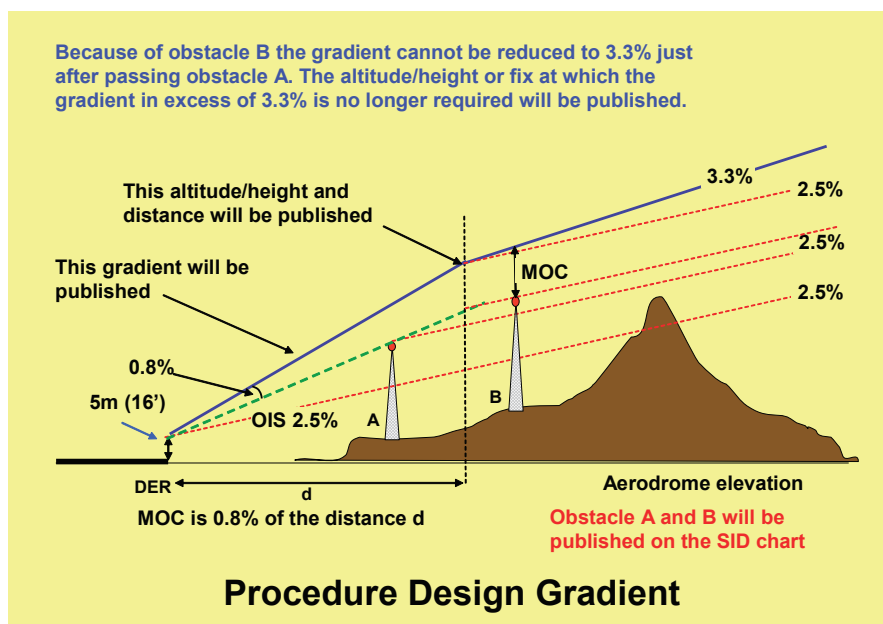

Figure 7.3:

7.8 Mountainous Terrain. What defines mountainous terrain is not specified. In deciding if the criteria for mountainous terrain are applicable, the designer takes notice of the prevailing wind conditions. If the average wind speed of 37 kph or more produces significant down draughts, increased obstacle clearance is applied.

7.9 Aircraft category. It has already been mentioned that the major consideration in planning a departure route is to ensure adequate obstacle clearance. In determining the track over which the aircraft will fly speed is the determining factor. Aircraft are categorized by the maximum speed that the departure procedure can be flown. Speeds for such departure procedures are defined in the table below. Wherever limiting speeds other than those specified in the table are published, they must be complied with to remain within the appropriate areas. If an aeroplane operation requires a higher speed, then an alternative departure procedure must be requested.

Aeroplane Categories for Departure Procedures

Aeroplane Category	Max Speed km/h (kt)
A	225 (120)
B	305 (165)
C	490 (265)
D	540 (290)
E	560 (300)

Maximum speed for turning departures

Figure 7.4:

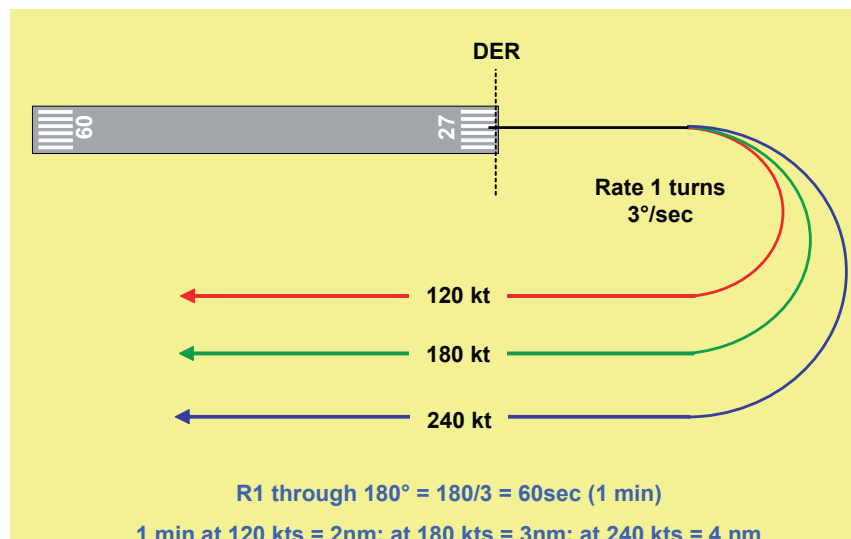

Figure 7.5:

7.10 Standard Instrument Departures. There are two basic types of departure route, straight, or turning. Departure routes are based on track guidance acquired within 20km (10.8nm) from the end of the runway (DER) for straight departures, and within 10km (5.4nm) after completion of turns for turning departures. When flying the route, the pilot is expected to correct for known wind and to remain within the protected airspace.

7.11 Straight Departure. A straight departure is one in which the initial departure track is within 15° of the alignment of the runway. Track guidance may be provided by VOR, NDB or RNAV.

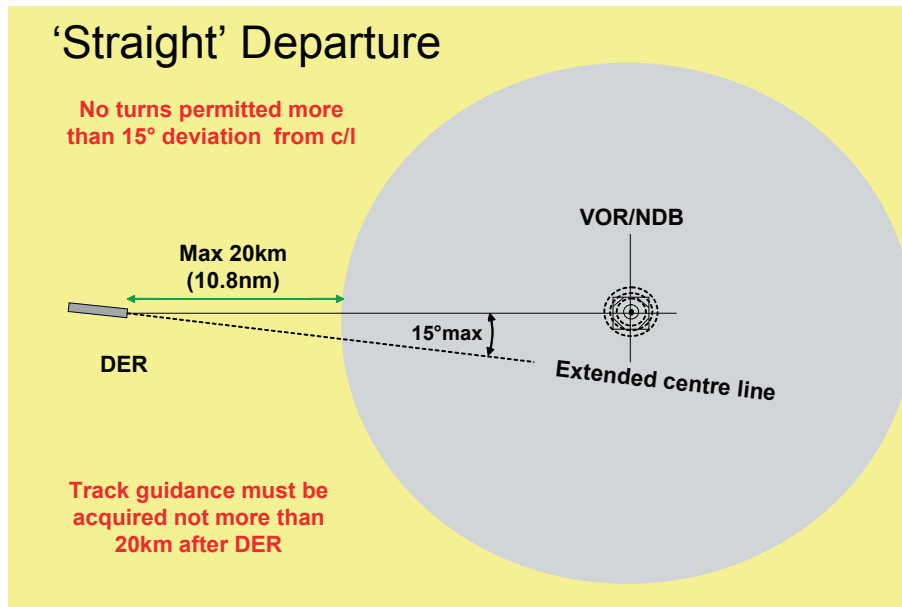

Figure 7.6:

7.12 Turning Departure. If the departure track requires a turn of more than 15° , a turning area is constructed and the turn required is commenced upon reaching a specified altitude/height, or at a fix or at a facility (VOR, NDB etc...). Straight flight is assumed until reaching an altitude not less than 120m (394 ft) above the elevation of the DER.

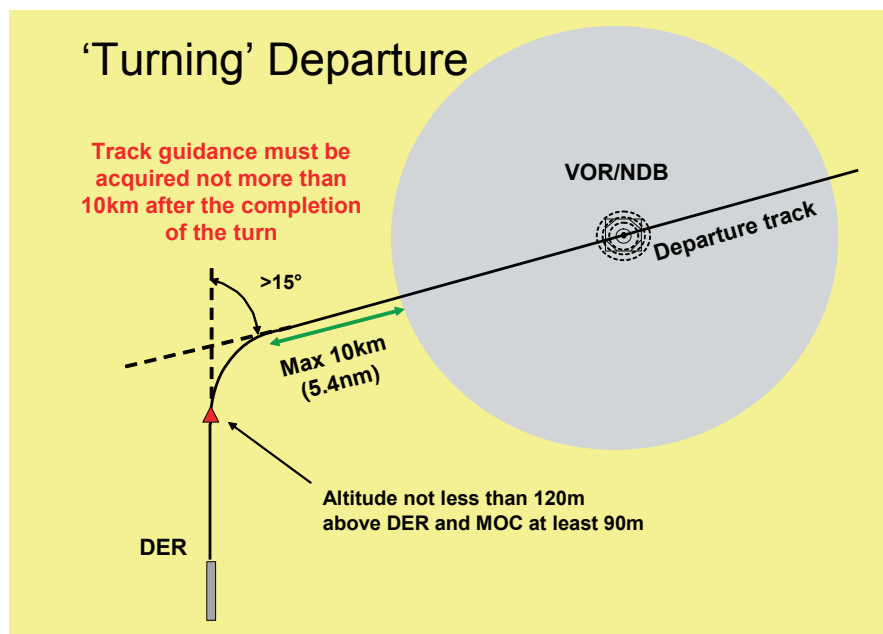

Figure 7.7:

7.13 Emergencies. It is the responsibility of the operator to establish procedures to cover the case of engine failure or an emergency in flight which occurs after V1.

7.14 Omni-directional Departures. Where no track guidance is provided in the design of a departure procedure, the omni-directional method is used which basically provides for initial departure tracks to be undefined. In other words, once off the end of the runway and at a safe height, the aircraft can be navigated in any direction required to achieve the initial en-route point. It may be that some sectors of the departure area may contain obstacles which preclude departures in that direction, in which case the published procedures will be annotated to show the restricted sectors. The basic procedure is that the aircraft will climb on the extended runway centre line to 120 m (394 ft) above aerodrome elevation before turns can be specified, and at least 90 m (295 ft) of obstacle clearance will be provided before turns greater than 15° can be specified. Turns will not commence within 600m of the beginning of the runway. Where obstacles do not permit the development of omni-directional procedures, it is necessary to fly a departure route (straight or turning), or ensure that ceiling and visibility will permit obstacles to be avoided by visual means.

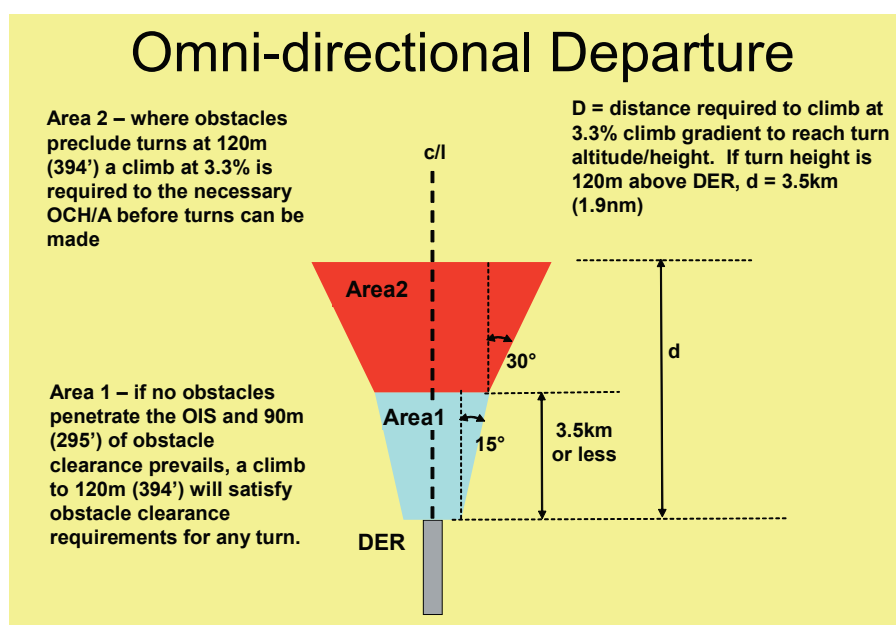

Figure 7.8:

7.15 Published Information. Departure routes and SID charts are published in accordance with standards contained in Annex 11 and Annex 4 to the Chicago Convention. Departure routes are labelled as RNAV (area navigation based on VOR/DME or GPS) only when that is the primary means of navigation utilised. For omni-directional departures, the restrictions will be expressed as sectors to be avoided or sectors in which minimum gradients and/or minimum altitudes are specified to enable an aeroplane to safely over fly obstacles. Minimum Sector Altitude (MSA) is also depicted on the plate and gives the lowest safe altitude for a defined sector (based on a navigational facility) to a range of 25nm from the aerodrome (or facility). The diagram on page 150 shows a typical SID plate. This plate details the departures from the runways at Heathrow and specifies that the point of joining the ATS route structure is the Compton VOR (CPT). All SIDs start at DER and end at the point of joining the ATS en-route system. Note that each route has a specific designator i.e. CPT3G. In the ATC clearance for IFR flights, departure instructions will include a SID to the first airways point. The ATCO will refer to the SID by its designator. Note the means by which track guidance is applied. In a normal aeroplane fully 'airways fitted' for IFR, the SID can always be complied with as there will be a minimum of two VOR/NAV boxes and one ADF. The Compton SIDs requires radio navigation using the LON and CPT VORs and the WOD NDB. DME is also specified.

The SID specifies DME distances to or from the facility with radials from VORs or QDMs for NDBs. The SID will also specify altitude restrictions in the form of “Above”, or “At”, as well as a diagram of the procedure. A narrative is always given in English. At the end of the SID the aircraft should be well placed to continue en-route climbing in the airway or under radar control. At any time during the procedure, the pilot may be ordered to comply with radar vectoring requiring abandonment of the SID or abbreviation of the procedure. In such cases the pilot will be told that the aircraft is under radar control.

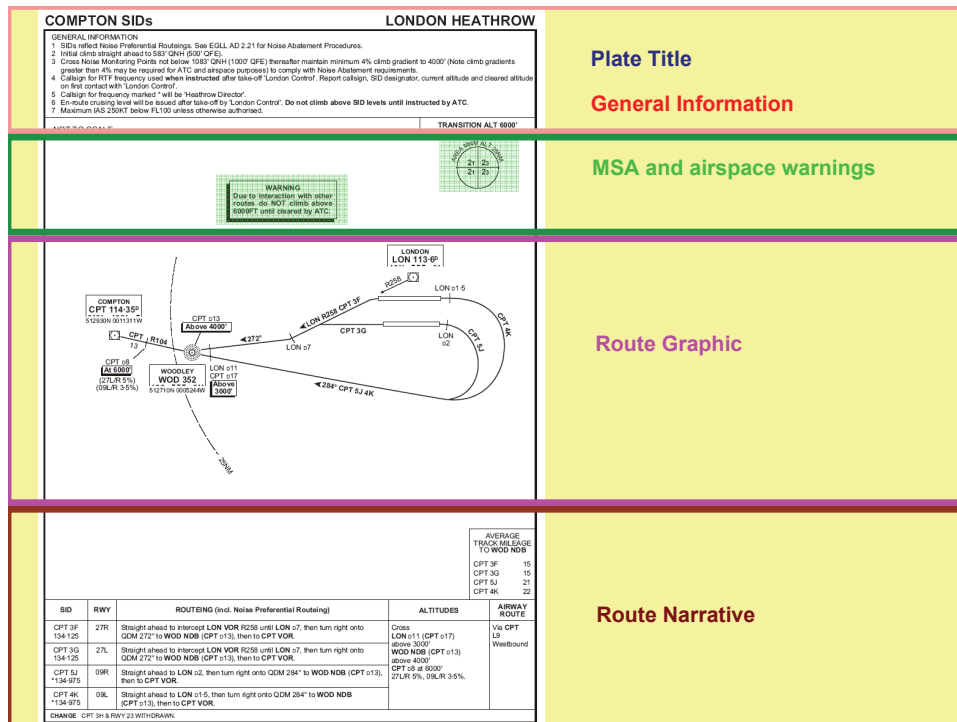

Figure 7.9:

7.16 Area Navigation (RNAV) and RNP Based Departure Procedures. The general principles relating to RNAV approach procedures also apply to RNAV departures based on a VOR/DME, DME/DME, basic GNSS and RNP criteria. Most FMS equipped aircraft are capable of following RNAV procedures but procedures may contain constraints to the on the system used. To use an RNP based procedure, the aircraft RNAV system must be approved for the published RNP and it must be confirmed before flight that the related VOR/DME stations are in fact working! Before flight, the pilot must also verify that the aircraft will be able to meet the RNP requirements for the segments to be flown as well as continue to monitor the system accuracy.

7.17 Turns. There are four kinds of turns that may be specified for an RNAV procedure:

- Turn at a fly-by waypoint;
- Turn at a fly-over waypoint
- Turn at an altitude/height; and
- Fixed radius turn (generally for RNP based procedures)

7.18 Use of FMS to Follow Conventional Departure Procedures. Where FMS is available, it may be used when flying the conventional departure procedures defined, provided the procedure is monitored using the basic display normally associated with that procedure, and the tolerances for flight using raw data on the basic display are complied with.

7.19 The Future. With the increasing utilisation and reliance on GPS as the primary means of navigation, procedures have been 'trialed' using pre-programmed FMS procedures based on GPS generated way points to define highly accurate instrument departures. Figure 7.19 below depicts the trial Precision RNAV departure procedure from Luton via Compton. The current 'reluctance' to commit totally to GPS will be resolved eventually and the full potential of the system will undoubtedly lead to greater flexibility in the design of departure procedures and enhanced use of limited airspace. Until then, the requirement will remain for a method to be used to 'cross check' the raw GPS data used as part of an instrument procedure.

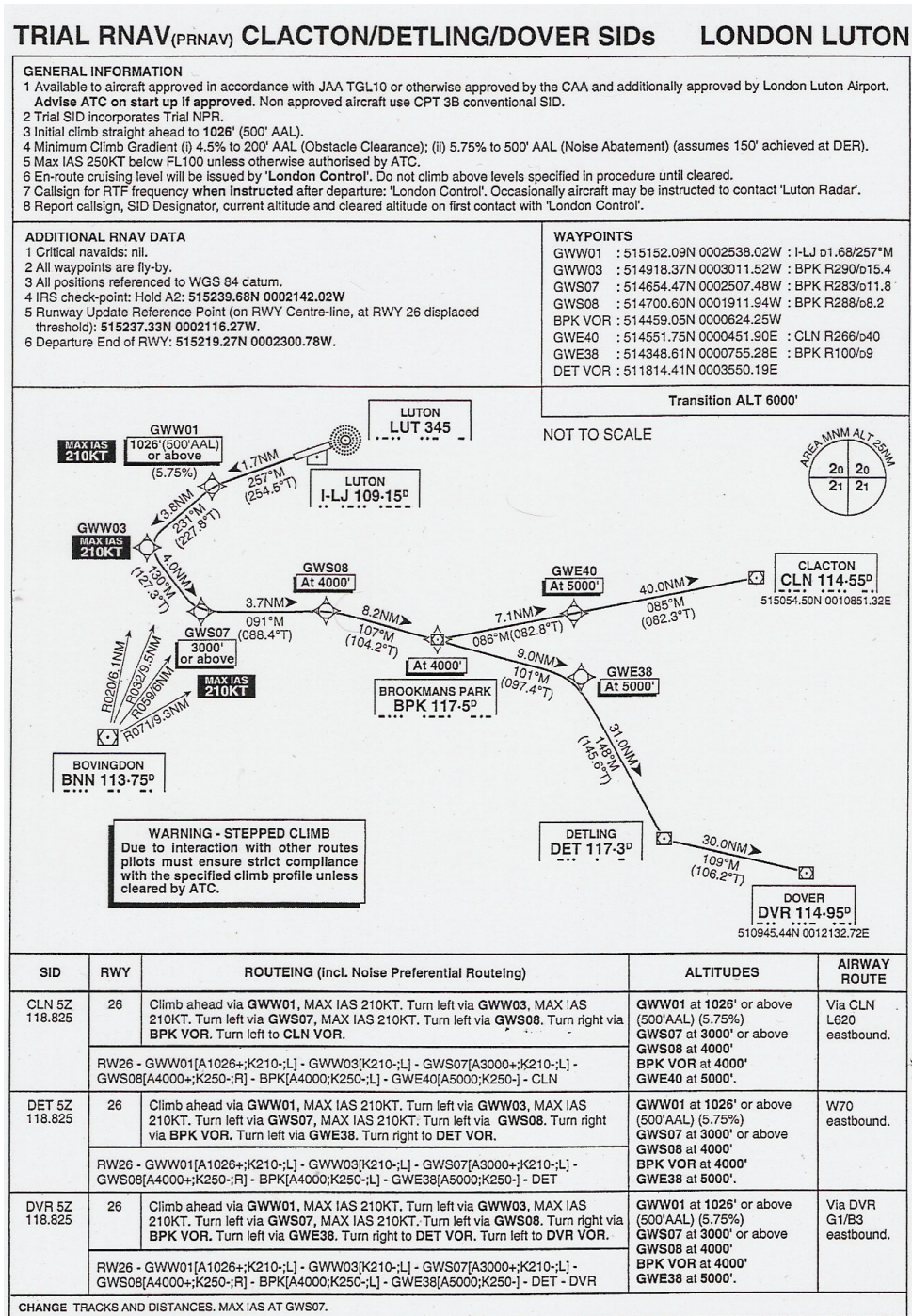

Figure 7.10:

QUESTIONS

1. During a straight departure, the initial track is to be:
 - a. within 5° of runway centre-line.
 - b. within 10° of runway centre-line.
 - c. within 15° of runway centre-line.
 - d. within 25° of runway centre-line.
2. In an instrument departure procedure the minimum obstacle clearance at DER is:
 - a. 0 ft.
 - b. 3.3% gradient.
 - c. 35 ft.
 - d. 0.8% gradient.
3. Turning departures provide track guidance within what distance of the completion of turns?
 - a. 15km.
 - b. 20km.
 - c. 10km.
 - d. 5km.
4. The MSA provides 300m obstacle clearance within how many miles radius of the navigation facility at the aerodrome?
 - a. 20nm.
 - b. 30nm.
 - c. 25nm.
 - d. 15nm.
5. What does the abbreviation DER stand for?
 - a. Distance to end of route.
 - b. Departure end of route.
 - c. Distance to end of runway.
 - d. Departure end of runway.
6. What does the abbreviation OIS stand for?
 - a. Obstacle identification surface.
 - b. Obstacles in surface.
 - c. Obstacle identification slope.
 - d. Obstruction identification surface.
7. The MSA which must be established around a navigation facility used in instrument procedures is in general valid within a sector of:
 - a. 15nm.
 - b. 30nm.
 - c. 25nm.
 - d. 10nm.

8. In a straight departure, what is the alignment of the initial track referenced to the runway centre line?
 - a. Within 45°.
 - b. Within 12.5°.
 - c. Within 15°.
 - d. Within 30°.

9. In general, what is the main factor that dictates the design of an instrument procedure?
 - a. The availability of navigation aids.
 - b. Airspace restrictions.
 - c. The terrain surrounding the aerodrome.
 - d. ATC requirements.

10. When following a SID, the pilot must:
 - a. calculate the track required and request ATC clearance to follow it.
 - b. fly the heading without wind correction.
 - c. adjust the track specified to allow for the wind.
 - d. fly the heading to make good the required track allowing for the wind.

11. For an Omni directional departure, the procedure dictates that the aircraft climbs on the extended centreline to a specified height before turning. What is this height?
 - a. 300m.
 - b. 120m.
 - c. 150m.
 - d. 250m.

12. If the track on an instrument departure is published the pilot is expected to:
 - a. correct for the known wind so as to stay within controlled airspace.
 - b. ask ATC for another heading to steer correcting for wind.
 - c. ignore the wind and proceed with a heading equal to the track.
 - d. ask ATC for permission to correct heading for wind.

ANSWERS

Question	Answer	Reference
1.	C	7.11
2.	A	7.7
3.	C	7.12
4.	C	7.15
5.	D	7.2
6.	A	7.2
7.	C	7.15
8.	C	7.11
9.	C	7.5
10.	D	7.6
11.	B	7.14
12.	A	7.6

CHAPTER EIGHT
APPROACH PROCEDURES

Contents

PROCEDURE BASICS	147
APPROACH PROCEDURE DESIGN	149
OBSTACLE CLEARANCE HEIGHT/ALTITUDE.	155
OPERATING MINIMA	155
DESCENT GRADIENTS.	158
TRACK REVERSAL AND RACETRACKS	159
PUBLISHED INFORMATION	164
RNAV APPROACH PROCEDURES BASED ON VOR/DME	167
QUESTIONS	169
ANSWERS	176

PROCEDURE BASICS

8.1 Introduction. Whilst in many ways the problems associated with arrivals are similar to those associated with departures, the primary concern of the procedure designer will inevitably be terrain clearance until the pilot is in a position to land the aircraft once in visual contact with the underlying ground. The initial design of an instrument approach procedure is, in general, dictated by the terrain surrounding the aerodrome. It is also affected by the type of operations and the types of aeroplane flying the procedures. These factors in turn, influence the types and positioning of navigation aids in relation to the runway or aerodrome. As we have already seen for departure procedures, airspace restriction may also affect the design of the procedure.

8.2 Speed/Categories of Aircraft. As with departure procedures, aircraft speed is an important consideration. Whilst the critical speed is the speed at which the aircraft crosses the threshold of the landing runway (V_{at}) as this will affect the spacing of aircraft on the approach, approach speeds will determine the dimensions of the areas within which manoeuvring may be carried out and hence the OCH calculations. The table below relates speed to the category of the aircraft (A-E).

Aircraft Category	V_{at}	Initial Approach speed range	Final Approach speed range	Max Speed for Visual Circling
A	<91	90/150 (110*)	70/100	100
B	91/120	120/180 (140*)	85/130	135
C	121/140	160/240	115/160	180
D	141/165	185/250	130/185	205
E	166/210	185/250	155/230	240

V_{at} = Speed at threshold based on $1.3 \times V_{so}$ or $1.23 \times$ stall speed (V_{s1g}) in landing configuration at max certificated landing mass
 * Maximum speed for track reversal or racetrack procedures

Figure 8.1: Aircraft categories for approach procedures.

8.3 Minimum Sector Altitudes (MSA)/Terminal Arrival Altitudes (TAA). For each aerodrome, MSA/TAA are established to provide at least 300m (984ft) obstacle clearance within 25nm of the navigation aid, IAF or IF associated with the approach procedures for that aerodrome. MSA/TAA is shown on all instrument plates and will be the lowest altitude permitted at the appropriate fix (normally the altitude at which the procedure begins). An arriving aircraft is permitted to descend below MSA only when: the aerodrome and underlying terrain are visible and will remain so; the aircraft is under radar control being radar vectored, or the aircraft is flying a published approach procedure.

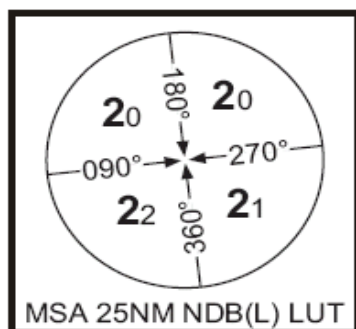

MSA as shown on the ILS/DME plate for London/Luton
 The altitude is shown in thousands and hundreds of feet i.e 22 is 2200ft
 The segments shown relate to the aircraft track i.e. the NW segment will include all arrival route tracks between 090 and 180 mag terminating at the LUT NDB

Figure 8.2:

8.4 Types of Procedure. Broadly, instrument procedures are defined in terms what guidance is provided. ICAO defines these as:

- Precision Procedures (runway approach) Categories I/II/III
- Non-precision Procedures (aerodrome approach)

8.5 Precision. A precision approach procedure gives accurate track guidance (azimuth) during the final approach segment and information concerning height above the threshold of the runway (elevation). In all cases external equipment is required to provide the necessary data. By flying the required track and glide path within the required accuracy of half scale deflection of the course deviation indicator (CDI), the aircraft is kept within a protected area which ensures terrain clearance (above OCA/H) throughout the procedure. ILS, MLS and Precision Approach Radar (PAR) are examples of equipment that can be used as part of a precision approach system. In the USA GLS (GPS landing systems) are now in use and first indications are that accuracy in the order of +/- 30cm to the centreline are achievable. In the design of the procedure (azimuth and elevation requirements), obstacle clearance is implicit if the descent path (glide path) is adhered to. Because a precision approach terminates at the touchdown point (or at the commencement of a missed approach) it is often referred to as a runway approach. For a precision approach the pilot is required to calculate the height on the final approach at which he/she must make a decision either to land or go around (fly the missed approach procedure). This is called Decision Altitude (Height) (DA(H)) and reflects the Operators declared aerodrome operating minima (covered in Operational Procedures). Guidance on the calculation of DA/H is contained in the Operations Manual. DA/H is defined as the specific altitude (or height) in a precision approach at which a missed approach must be initiated if the required visual reference to continue the approach has not been established. The Operator is also required to specify the required visual criteria in the Operations Manual.

8.6 Precision Categories. It must be emphasised that at DA/H, if the approach has been flown correctly, the aircraft will be at the place it should be and must therefore be safe, and further descent along track must also be safe (if the visibility was perfect, the aeroplane would be at the same place and height, and the approach would be continued anyway!). Except where the 'system' (ground equipment and aeroplane equipment) permits 'blind' landing, the latter stage of the final approach will be flown visually (the pilot will need visual reference to complete the landing). In order to accomplish this, a minimum RVR is required and also a visual means of maintaining the centreline of the runway once on the ground. As technology has advanced, systems, specifically ILS, have become more accurate in track and height guidance. The use of 'on board' computer systems (FMS) to interpret received data and to control the aeroplane means that the visual element can be reduced to the minimum. ILS systems are categorised by accuracy of operation. The categories are as follows, but beware; there are anomalies between ICAO and JAR OPS requirements. System Minima is discussed in section 8.31 below. For Air

Law, only the ICAO requirements are examinable. The ICAO categories are:

- **Cat I** System Minima 60m (200ft); DH \Rightarrow 60m (than 200ft), and RVR not less than 550m or ground visibility not less than 800m
- **Cat II** System Minima 30m (100ft); DH < 60m (200ft) but \Rightarrow 30m (100ft), and RVR not less than 350m
- **Cat IIIA** No system minima; DH < 30m (100ft) or no DH, and RVR not less than 200m
- **Cat IIIB** No system minima; DH < 15m (50ft) or no DH, and RVR less than 200m but more than 50m
- **Cat IIIC** No system minima; no DH and no RVR requirements

8.7 Non Precision. Where there is no ground equipment that can provide height (elevation) data to the aircraft, the procedure is defined as non-precision although the track guidance accuracy may be as good as that required for precision. Non precision procedures can be established where track guidance is provided by VOR or NDB, or by track guidance elements of precision systems i.e. ILS localiser only or PAR in azimuth only. Another type of non precision system is surveillance radar on a reduced range scale (SRA). Because there is no reference to touchdown for non precision procedures and the procedures always terminate above touchdown, the procedures are sometimes referred to as aerodrome approach procedures. Indeed, some procedures are specified for approach to the aerodrome, followed by a circling manoeuvre complying with defined visual criteria to land in a direction other than that of the straight in approach. This is known as Visual Manoeuvring (Circling) and is discussed in detail in chapter 9.

8.8 Visual Approach. In all cases, once established on final approach, the pilot has the option to continue the approach visually providing, of course, that he/she has the necessary visual criteria specified by the operator. This is not VFR! It is completing the IFR procedure visually. Unless Cat IIIC applies, the pilot will need some form of visual criteria anyway, so if the criterion is obtained at 7 miles from touchdown, what is the difference!

8.9 Completing the Procedure. Once an instrument procedure has been commenced the pilot must complete the procedure as published unless given contrary instructions by ATC. Even if the final approach is flown visually, the requirements of the procedure must be complied with. An instrument approach ends with either a successful landing or completion of the missed approach procedure. In any event, if the procedure is abandoned after passing the IAF, the missed approach procedure must be flown, starting from the MAPt, with the aircraft climbing to the altitude specified for the missed approach as soon as possible (this will usually be the highest MSA or the lowest altitude specified for commencing the procedure at the IAF).

8.10 Limitations. An instrument approach shall not be continued beyond the outer marker fix, or if no OM is provided the equivalent position, in case of precision approach, or below 300 m (1000ft) above the aerodrome in case of non-precision approach, unless the reported visibility or controlling RVR is above the specified minimum. If, after passing the outer marker fix, or equivalent position, in case of precision approach, or after descending below 300 m (1000ft) above the aerodrome in case of non-precision approach, the reported visibility or controlling RVR falls below the specified minimum, the approach may be continued to DA/H or MDA/H. If the required visual criteria are then obtained at DH the aircraft may be landed.

APPROACH PROCEDURE DESIGN

8.11 Procedure Requirements. An instrument approach procedure requires the aeroplane to be flown in safe airspace. In order to remain in safe airspace the required track of the aeroplane must be achievable and the altitude limitations which need to be applied must be commensurate with what is trying to be achieved. As the procedure takes the aeroplane closer to the runway/aerodrome and closer to the ground, the safety limitations must be increased not relaxed. Until 3-D satellite navigation technology is widely available and proved reliable, the system of guidance in azimuth and elevation will rely on ground based equipment which has inherent errors. Providing the error tolerances are known and the design of the procedure detailing the flight path to be flown takes the error tolerances into account, the procedure will be useable. It does of course require the pilot (or the auto-pilot) to be able to fly the aeroplane to the required basic accuracy to keep the aeroplane in the airspace specified. The procedure will define tracks to be made good, therefore the pilot must make allowance for the wind. An instrument approach procedure has five separate segments, each of which has a specific purpose. Each of the five segments begins and ends at a designated fix. It is, however, possible for segments to begin at specified points if no fix is available. For instance, the final approach segment of a precision approach may begin at the point of intersection of the intermediate flight altitude and the glide path.

8.12 Procedure Segments. An approach procedure consists of five parts or segments. These are:

- The Arrival Segments or Route (see 8.17 below)
- The Initial Segment (see 8.18 below)
- The Intermediate Segment (see 8.19 below)
- The Final Segment (see 8.20 below)
- The Missed Approach Procedure (see 8.44 below)

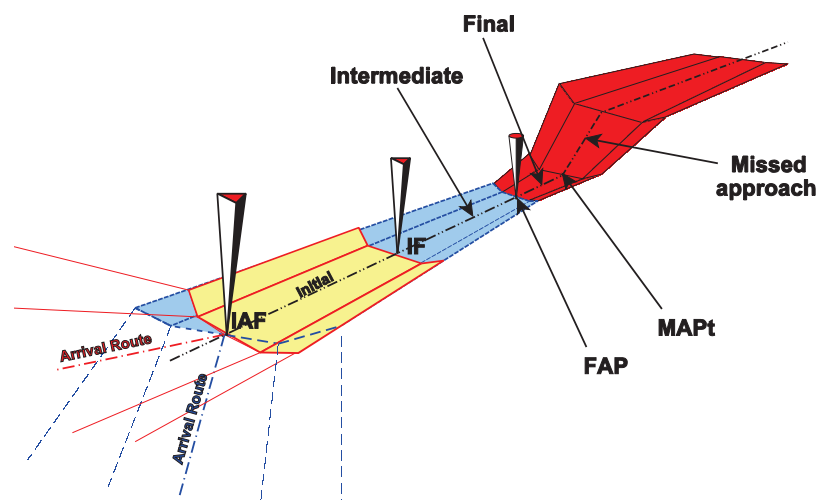

Figure 8.3: Procedure segments.

8.13 Straight-in Approach. Wherever possible a straight-in approach will be specified in which each segment is aligned with the extended runway centreline. However, a non-precision approach may specify the final approach track converging to the runway heading at an angle of 30° or less. In all cases, the procedures depict still air tracks and pilots are required to make allowance for the wind to make good the specified track. If terrain or other restrictions preclude a straight in approach, a circling approach will be specified.

8.14 Physical Characteristics of Segments. The vertical cross section of each segment is divided into primary and secondary MOC areas. Full obstacle clearance is applied over the primary area, reducing to zero at the outer edges of the secondary areas.

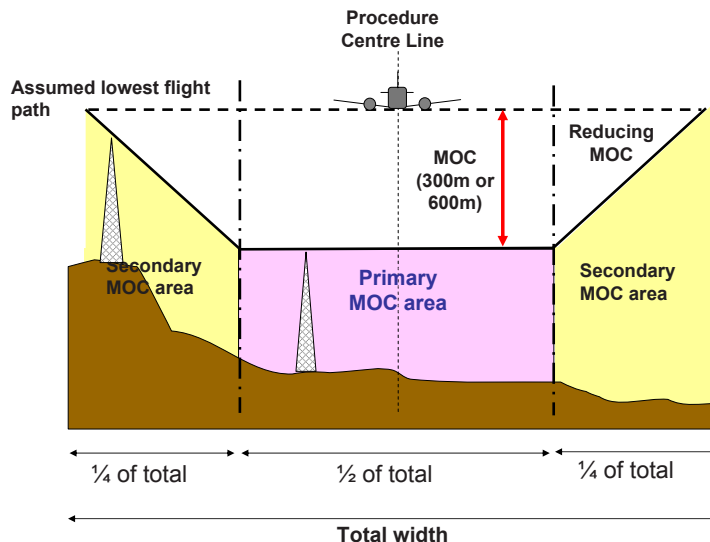

Figure 8.4: Characteristics of segments.

8.15 Fixes and Fix Accuracy. The fixes used in instrument procedures are generally based on data from radio navigation aids i.e. VOR. The fix may be an ‘on top’ to a beacon or a point defined by a DME range on a specified radial (way point). In any event, the accuracy of the fix is of paramount importance because the width of the MOC area will be based upon this. For ‘on top’ fixes the type of aid is a limiting factor. For instance, a VOR is designed to give accurate track guidance but is quite poor in giving an ‘on top’ indication due to the size of the ‘cone of confusion’ over the beacon. An NDB on the other hand, gives a better ‘on top’ but the track guidance is worse! Where an accurate ‘on top’ is required, i.e. the outer marker of a CAT 1 ILS, a 75 MHz (or ‘Z’ or ‘fan’ marker) is used which is designed specifically for that purpose. Where a fix is specified using information from two separate systems i.e. VOR radial and DME range, the inaccuracies of each system must be aggregated to define a fix tolerance area. In determining the accuracy of fixes the following bearing error is assumed:

- VOR $\pm 4.5^\circ$
- ILS Localiser $\pm 1.4^\circ$
- NDB $\pm 10.3^\circ$

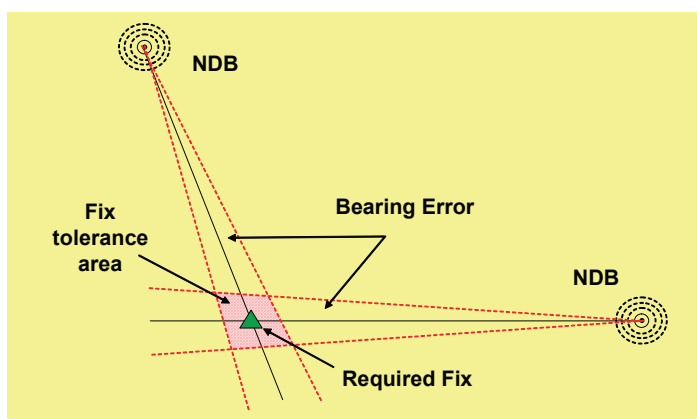

Figure 8.5:

8.16 Track Guidance Accuracy. The width of the MOC area is also dependant upon the accuracy of the track guidance provided by the navigation aids used. The track accuracy for the various aids is defined as follows:

- VOR ± 5.2°
- ILS Localiser ± 2.4°
- NDB ± 6.9°

8.17 Arrival Route/Segment. The arrival segment begins at the point the aircraft departs from the en-route airways system to begin the instrument arrival. This will normally be a radio navigation facility. If this is 25nm or more from the aerodrome, a standard arrival route (STAR) will be specified. The STAR plate below shows the arrival routes for London Heathrow from the northwest (via the Ockham (OCK) VOR). If the distance is less than 25 nm then the aircraft will route directly from the point of leaving the airway to the facility serving as the IAF for the procedure. In either case, the en-route MOC is applied and the altitude specified for the aircraft to be over the IAF is not below the highest MSA for the aerodrome. It is usual for aircraft to be radar vectored from a convenient point, to the final approach track.

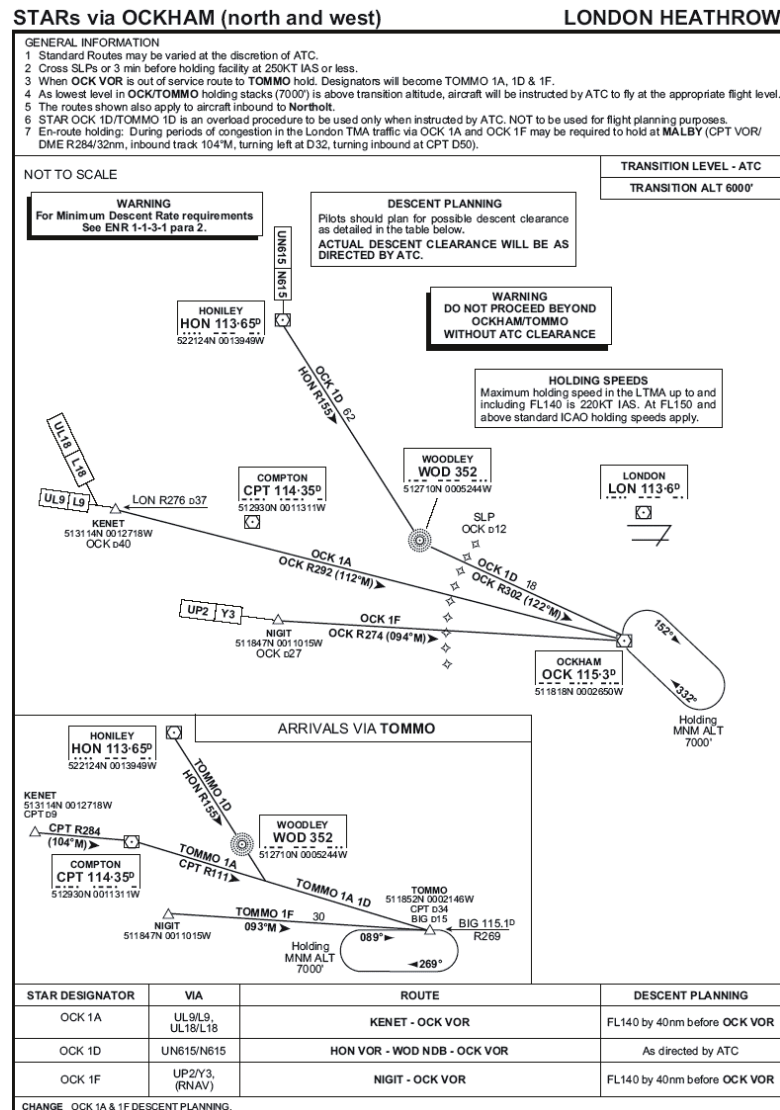

Figure 8.6:

8.18 Initial Segment. In the initial segment, the aircraft is directed to a point at which the intermediate segment can be intercepted. It starts at the IAF and ends at the IF. Aircraft speed and configuration will depend upon distance from the aerodrome and any need for descent. MOC in the initial segment is 300m (984ft). Track guidance is normally provided with a maximum intercept angle to the IF of 90° for a precision approach and 120° for a non-precision approach. If track guidance to the IF is not available, a DR segment may be specified. For the DR segment, the interception angle to the intermediate segment track must be no greater than 45°, and the length of the DR track, no more than 10nm. Where a straight-in approach is not feasible or there is no suitable remote IAF or IF, a track reversal, racetrack or holding pattern is required.

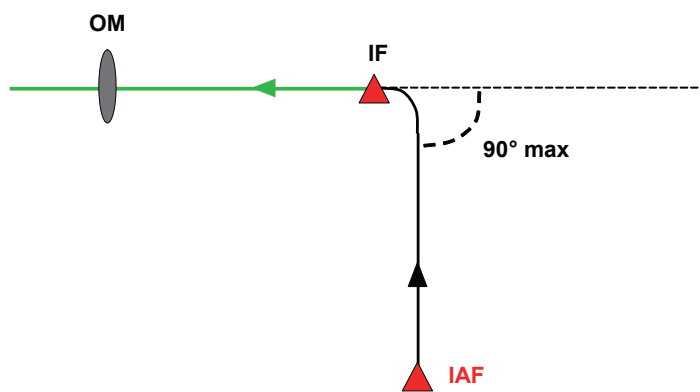

Figure 8.7: IAF to IF (precision approach).

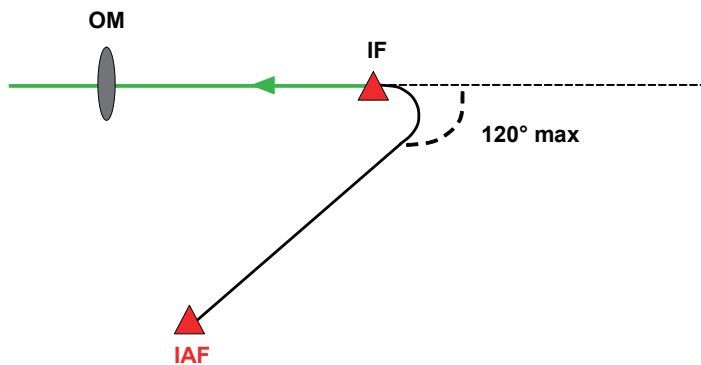

Figure 8.8: IAF to IF (non precision approach).

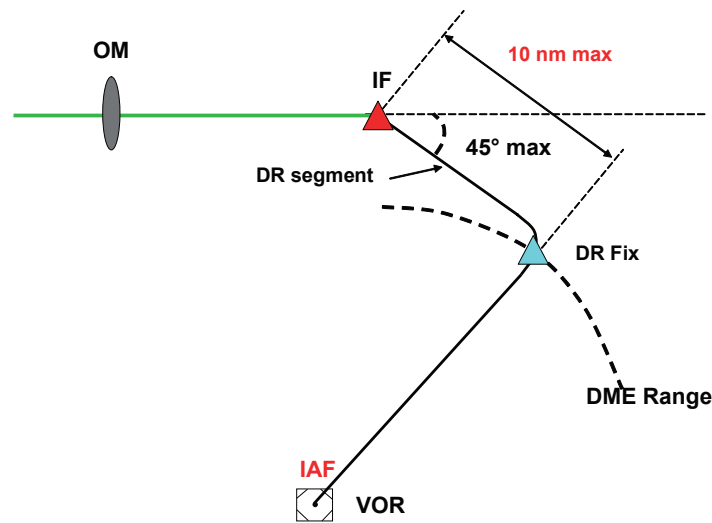

Figure 8.9: IAF to IF (DR segment).

8.19 Intermediate Segment. This is the segment in which the aircraft speed and configuration is adjusted to prepare for the final approach. Descent in this segment is kept to a minimum. It starts at the IF and ends at the FAF. If no FAF exists, it ends when the aircraft is established on the final inbound track. The MOC in the intermediate segment reduces from 300m at the IF to 150m at the end of the segment.

8.20 Final Segment. The beginning of the final segment depends upon the type of approach and the availability of a suitable FAF. In this segment, the aircraft is finally configured, alignment with the runway takes place and descent for landing is commenced.

8.21 Non Precision with FAF. For a non-precision procedure with a FAF, the final segment starts at the FAF and ends at the MAPt. The FAF will be positioned on the final approach track at a distance from the threshold of the landing runway that permits aircraft configuration for final approach/landing and descent from the intermediate altitude to the MDA/H. MOC is incorporated in the calculation of MDA/H. The optimum distance of the FAF from the threshold is 5nm and the maximum is 10nm. The required descent gradient should be 300ft/nm (approx 3°). A step-down fix may be incorporated for obstacle clearance purposes in which case, two OCA/H values will be published.

8.22 Non Precision without FAF. This situation will normally occur at an aerodrome where there is only one facility on or near the aerodrome that is used as both the IAF and the MAPt. In this case it is unlikely that the final approach track will be aligned with the runway centreline and therefore descent to MDA/H will be made when the aircraft is established inbound on the final approach track.

8.23 Precision Approach. For ILS/MLS the final segment begins at the Final Approach Point (FAP). This is defined as the point in space on localiser centreline (or the specified MLS azimuth) where the intermediate approach altitude intercepts the nominal glide path. This can occur at heights between 300m (1000ft) and 900m (3000ft) which in the case of a 3° (300ft/nm) glide path, will be between 3nm and 10nm from touchdown. MOC is included in the calculation for DA/H but requires the pilot to fly the aircraft with no more than half scale deflection of the CDI. At some point during the final segment, a fix will be specified where glide path information can be verified.

8.24 Constant Approach Slope (Stabilised Approach). Primarily for the avoidance of wake turbulence separation but also for economy and noise abatement, a procedure known as stabilised approach has been developed. The procedure requires the aircraft to depart from the IAF and descend at a constant rate (300ft/min) throughout the procedure. Wake turbulence separation (see chapter 16) is only applicable between approaching aircraft where the second aircraft is at the altitude as, or within 1000ft below, the preceding aircraft. So, by ensuring that the subsequent aircraft is always above the preceding aircraft there is no requirement for wake turbulence separation. Control of the rate of descent is achieved by aircraft attitude negating the need for power changes thus reducing noise. Also, by setting a constant power, minor economy in fuel usage is achieved which, when multiplied by the total of the operation, may well represent a considerable economic and environmental saving.

8.25 Missed Approach. In the event that the necessary visual criteria is not obtained at DA/H or MDA/H the final part of an instrument procedure permits a return to the IAF for another attempt or to establish the aircraft on a departure profile to go to another (alternate) aerodrome. Missed approach is covered in detail at section 8.44.

OBSTACLE CLEARANCE HEIGHT/ALTITUDE

8.26 Obstacle Clearance Altitude/Height (OCA/H). During the development stage of the design of a procedure, the OCA/H is determined by the authority of the state through survey. This will be the height/altitude at or above which an aircraft must be flown to avoid the dominant obstacle. It will consist of the height of the obstacle plus the minimum obstacle clearance (MOC) allowance. This information will be published on the instrument procedure plate and is aircraft category dependant. OCA/H is the lowest that MDA/H can be.

8.27 DA/H for Precision Approach Procedure. This is defined as the lowest altitude or height at which a missed approach must be initiated to ensure compliance with the appropriate obstacle clearance criteria. The reference datum for a precision approach is always the threshold of the landing runway.

8.28 OCA/H for Non-precision Approach. This is defined as the lowest altitude or height below which the aircraft cannot descend without infringing the appropriate obstacle clearance criteria. For non precision procedures the reference datum is the aerodrome elevation or the elevation of the relevant runway threshold (if the threshold is more than 2 m (7 ft) below the aerodrome elevation).

8.29 OCA/H for Visual Manoeuvre (Circling) (VM(C)). This is defined as the lowest altitude or height above the aerodrome elevation, below which the aircraft cannot descend without infringing the appropriate obstacle clearance criteria. It is based on the highest obstacle in the VM(C) area with respect to the aerodrome elevation.

OPERATING MINIMA

8.30 Operating Minima. In accordance with Annex 6 and JAR-OPS 1, the operator is required to ensure that the aerodrome minima are specified for all aerodromes used in the operation. Part of this ensures that in all cases, DA/H or MDA/H is calculated taking into account the OCA/H published and the upper margin. The upper margin is specified by the operator and may be zero in which case DA/H or MDA/H would be the same as OCA/H. It takes into account data that is variable in nature i.e. the crew qualification; the OAT; anomalies in the configuration of the instrument system etc....

8.31 System Minima. To ensure that the minima are realistic and give sufficient 'buffer' to allow for anomalies, for each method of conducting an instrument approach, a minimum height above the datum is specified below which an approach is not permitted to continue without the necessary visual reference. This height is known as system minima and overrides a lower DH or MDH. For instance, the system minimum for a CAT 1 ILS is 200 ft. If OCH plus the upper margin for a CAT 1 ILS approach is calculated at 170ft, then system minimum would prevail and DH would be 200ft. If on the other hand, DH is calculated at 230ft then, as this is higher than system minimum, DH remains 230ft. For Air Law, the student is only required to know the system minima for ILS CATs I/II/III. Note that for CAT III, DH can be zero; therefore system minimum for CAT III must also be zero.

Category	System minimum
CAT I	60m (200ft)
CAT II	30m (100ft)
CAT III	Not applicable

Figure 8.10: ICAO system minima for ILS.

8.32 Calculation of DA/H. The diagrammatic representation of the method of calculation of DA/H is shown below.

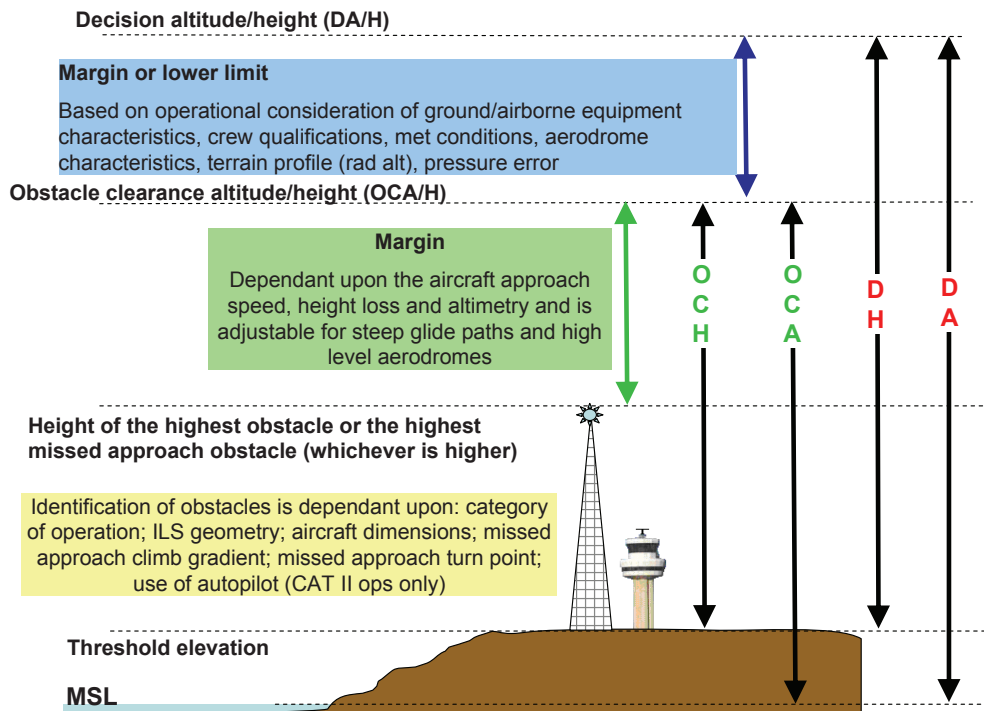

Figure 8.11: Method of determining DA/H for precision approaches.

8.33 **Specific Data for ILS/MLS.** In determining the criteria for DA/H for ILS/MLS other data needs to be taken into account and requirements specified. Wing span and the vertical distance between the wheels and the GP aerial limitations are specified as follows:

Aircraft category	Wing Span (m)	Vertical distance between the wheels and the GP aerial
H	30	3
A, B	60	6
C, D	65	7
D _L	80	8

Figure 8.12: Limitations for ILS.

Note: Category D_L has been included to cater or the A380. Category H refers to Helicopters.

Other criteria for ILS include:

- CAT I is flown with pressure altimeter
- CAT II is flown with radio altimeter and flight director
- Missed approach climb gradient is 2.5%
- Glide path angle is 2.5° minimum and 3.5° maximum. CAT II/III requires 3°

8.34 **Calculation of MDA/H.** The diagrammatic representation of the method of calculation of MDA/H is shown below.

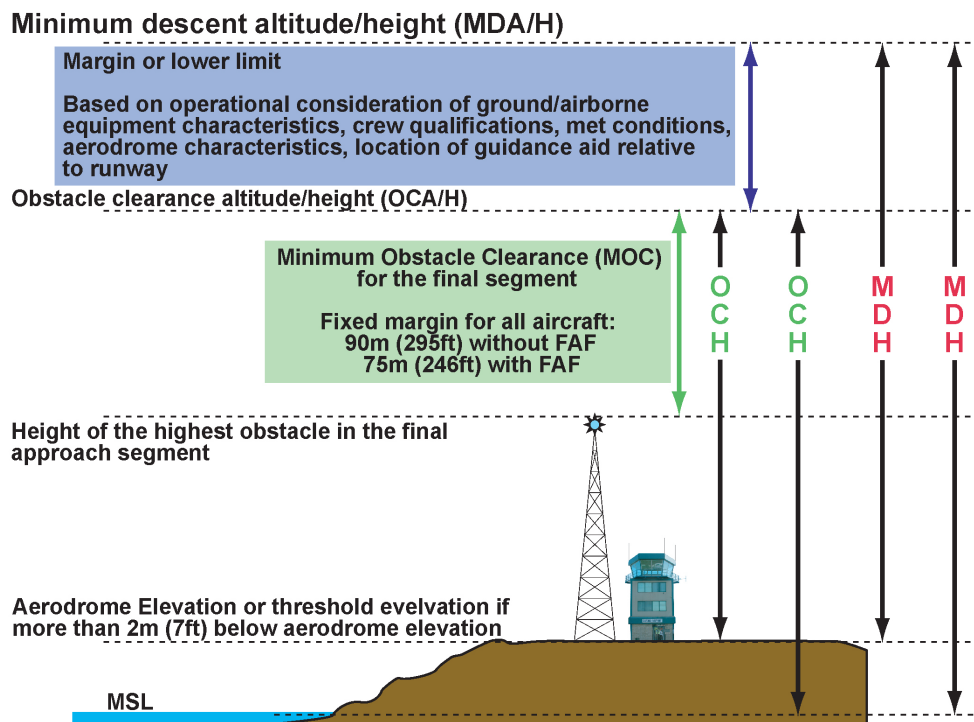

Figure 8.13: Method of determining DA/H for non precision approaches.

8.35 **Calculation of MDA/H for VM(C).** The diagrammatic representation of the method of calculation of DA/H is shown below

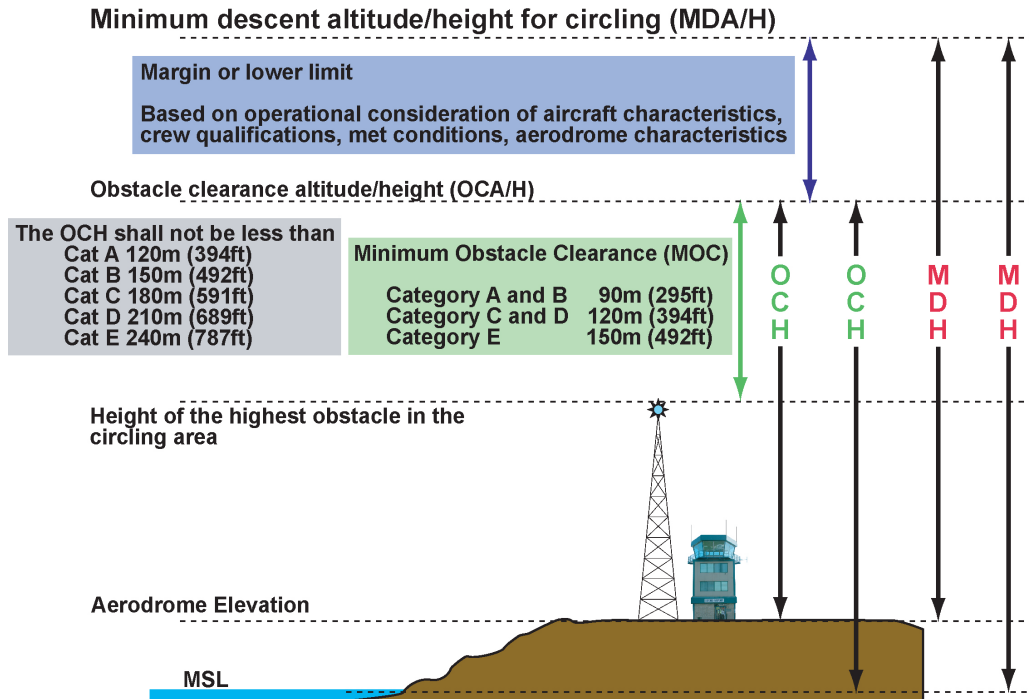

Figure 8.14: Method of determining DA/H for circling approaches.

DESCENT GRADIENTS

8.36 **Descent Gradient.** The design of procedures must allow adequate space for descent from the published height crossing the facility, to the runway threshold. This is achieved by establishing a maximum allowable descent gradient for each segment of the procedure with the most critical being the final segment where threshold speed (or the ability to decelerate to it) will be a function of gradient. The optimum descent gradient in the final approach should not exceed 5% (50 m/km; approx 300 ft/nm) which is equivalent to a 3° glide path. Where a steeper gradient is necessary the maximum permissible is 6.5% (65 m/km (400 ft/nm) which is equivalent to a 3.8° glide path). In the case of a precision approach the operationally preferred glide path angle is 3° and this is mandatory for CAT II/III. An ILS GP in excess of 3° is used only where an alternative means of satisfying obstacle clearance requirements is impractical.

8.37 **High Rate Descents.** Gradients over 6.5% may result in descent rates exceeding the recommended maximum rate of descent for some aircraft. Pilots flying such approaches should be aware of this before starting the approach. High rate descents are not permitted as a means of avoiding noise abatement procedures. Where GPs greater than 6.5% are established (i.e. 9.5% /5.5° at London City), the authority of the state in which the aerodrome is situated must give specific approval; the operator must be approved to carry out high rate descents; specially approved aircraft must be used and pilots specially trained.

TRACK REVERSAL AND RACETRACKS

8.38 Requirement. If a straight in approach is not possible (or feasible), a procedure may be established using a facility on the aerodrome that serves both as the IAF and the MAPt. In this case, some form of track reversal procedure will be required in which the aircraft is flown outbound from the facility on a defined procedure, and then turned to fly inbound back towards the facility. This may be a procedure turn or a base turn.

8.39 Procedure Turn. A procedure turn is defined as a turn from outbound to inbound in which the tracks flown are reciprocal. There are two types:

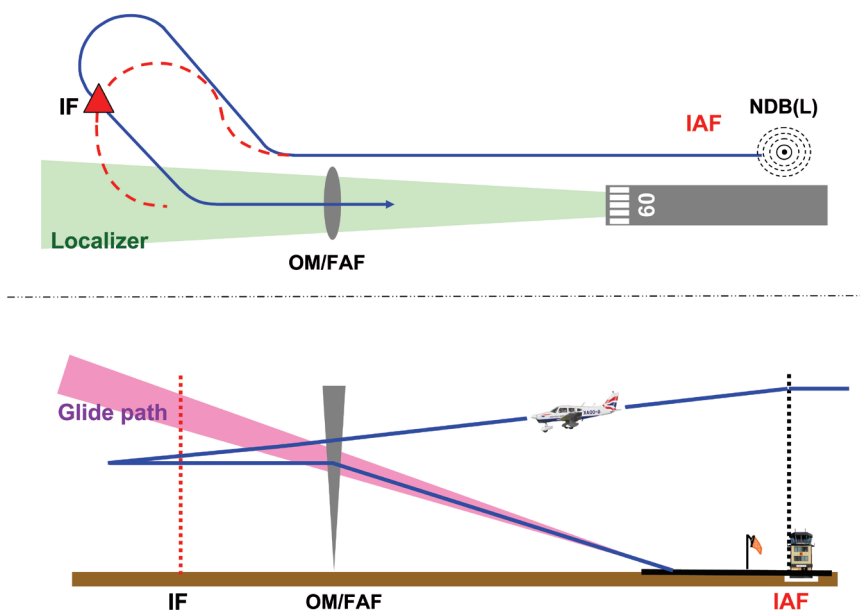

Figure 8.15: Track reversal - procedure turn.

8.40 45°/180° Procedure Turn. This requires track guidance to a point (timed or DME) where a 45° turn is made followed by a straight leg of either 1 minute (category A or B aircraft) or 1 minute and 15 seconds (category C, D and E). At the end of the timed leg a rate 1 turn is made through 180° to bring the aircraft into a position intercept the reciprocal of the outbound track at an interception angle of 45°.

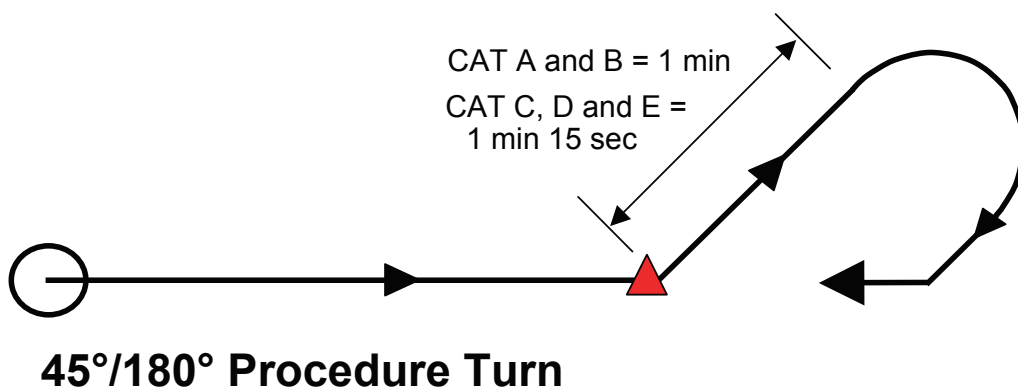

Figure 8.16: 45°/180° - procedure turn.

8.41 **80°/260° Procedure Turn.** This requires track guidance to a point (timed or DME) where an 80° rate 1 turn is made followed immediately by an opposite direction 260° rate 1 turn. In still air, this should bring the aircraft on to the reciprocal of the outbound track. Also in still air, the procedure should take exactly 2 minutes.

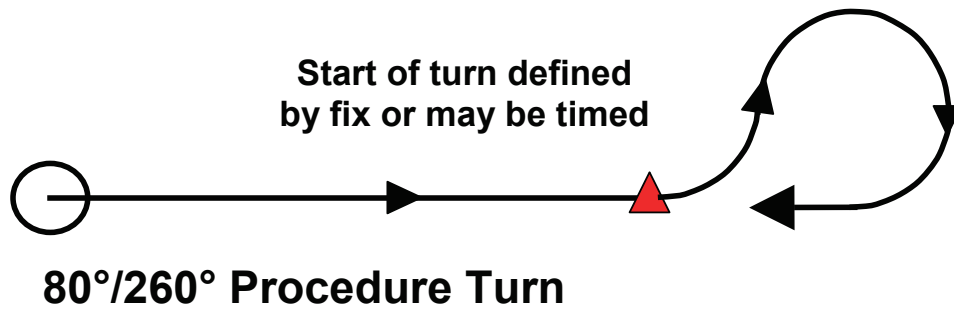

Figure 8.17: 80°/260° - procedure turn.

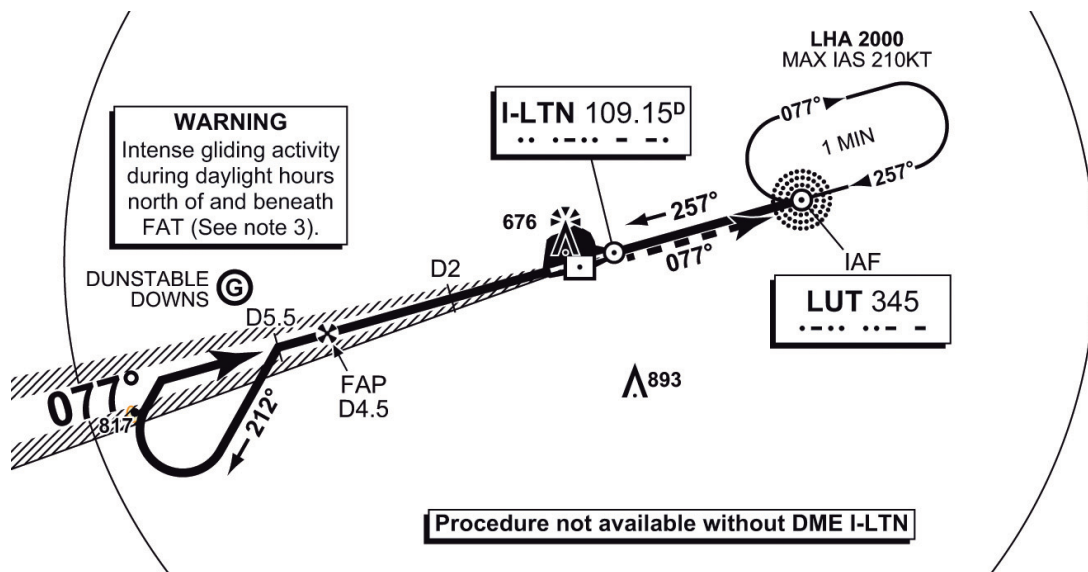

Figure 8.18: Procedure turn shown on an approach plate.

8.42 **Base Turn.** Where accurate outbound track guidance can be provided by an NDB or VOR, a base turn can be specified where the inbound track is **not** the reciprocal of the outbound track. The specified outbound track is followed to a pre-determined point at which a rate 1 turn is made so that the aircraft rolls out on the required inbound track.

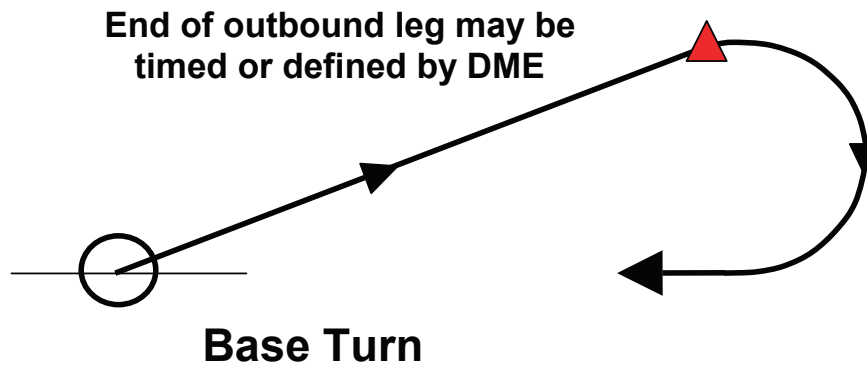

Figure 8.19: Base turn.

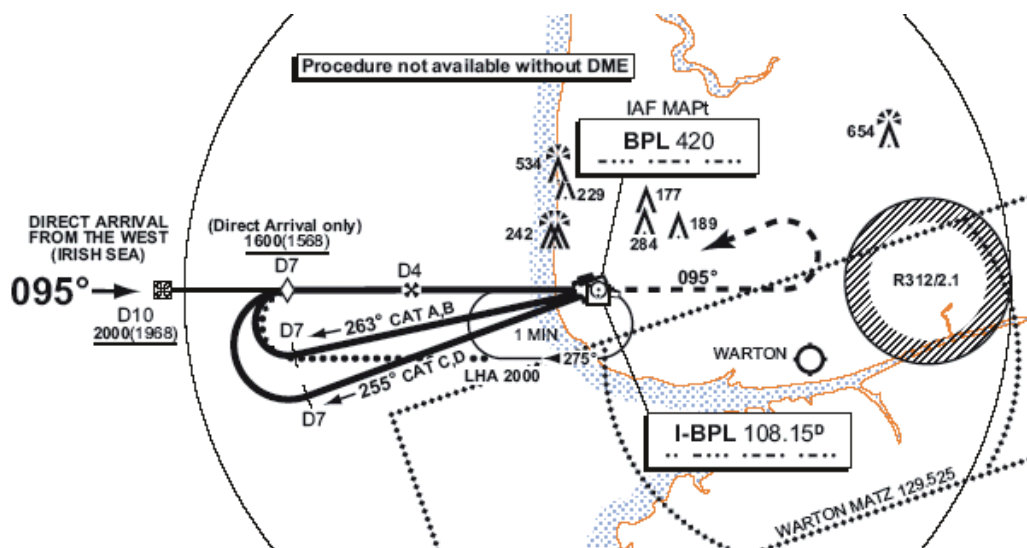

Figure 8.20: Base turn shown on an approach plate.

8.43 Racetrack Procedure. A racetrack consists of a turn from the inbound track through 180° at the facility or a fix after which, the outbound leg is flown to a point defined by time or a fix at which another turn through 180° is made to bring the aircraft back on to the inbound track. It is used where aircraft are required to enter a holding pattern prior to commencing the instrument procedure, and where the orientation of the holding pattern does not permit either a procedure turn or a base turn to be used. It will normally be specified as an 'alternate procedure' and specific instructions will be included on the plate.

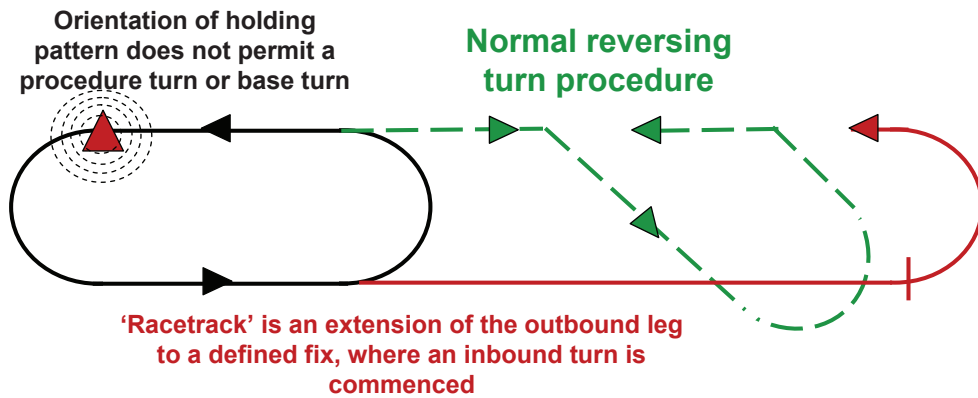

Figure 8.21: Racetrack procedure.

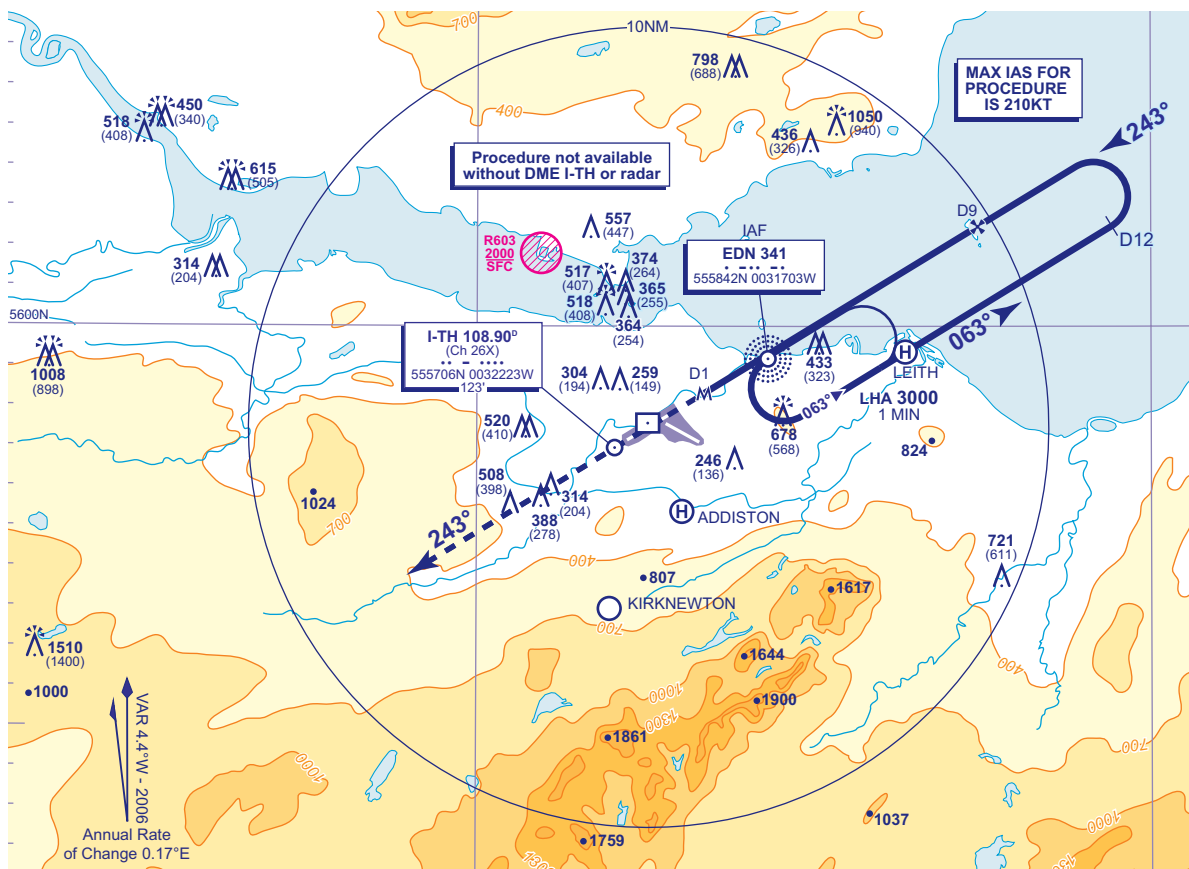

Figure 8.22: Racetrack shown on an approach plate.

MISSED APPROACH SEGMENT AND PROCEDURE

8.44 The Procedure. If the necessary visual criteria is not obtained at decision height (DH/A) or minimum descent height (MDH/A), or at any time during the instrument approach procedure that the pilot is unable to continue the approach, the instrument procedure requires the pilot to fly a missed approach. This procedure is always detailed on the instrument plate together with the loss of RTF procedure. The published information will always include a climb to at least MSA and as soon as the pilot elects to fly the missed approach procedure, a climb to that altitude should be initiated. If the aircraft is already at that altitude, it should be maintained. The climb gradient for the procedure is normally 2.5%. A missed approach procedure consists of three phases:

- Initial missed approach
- Intermediate missed approach
- Final Missed approach

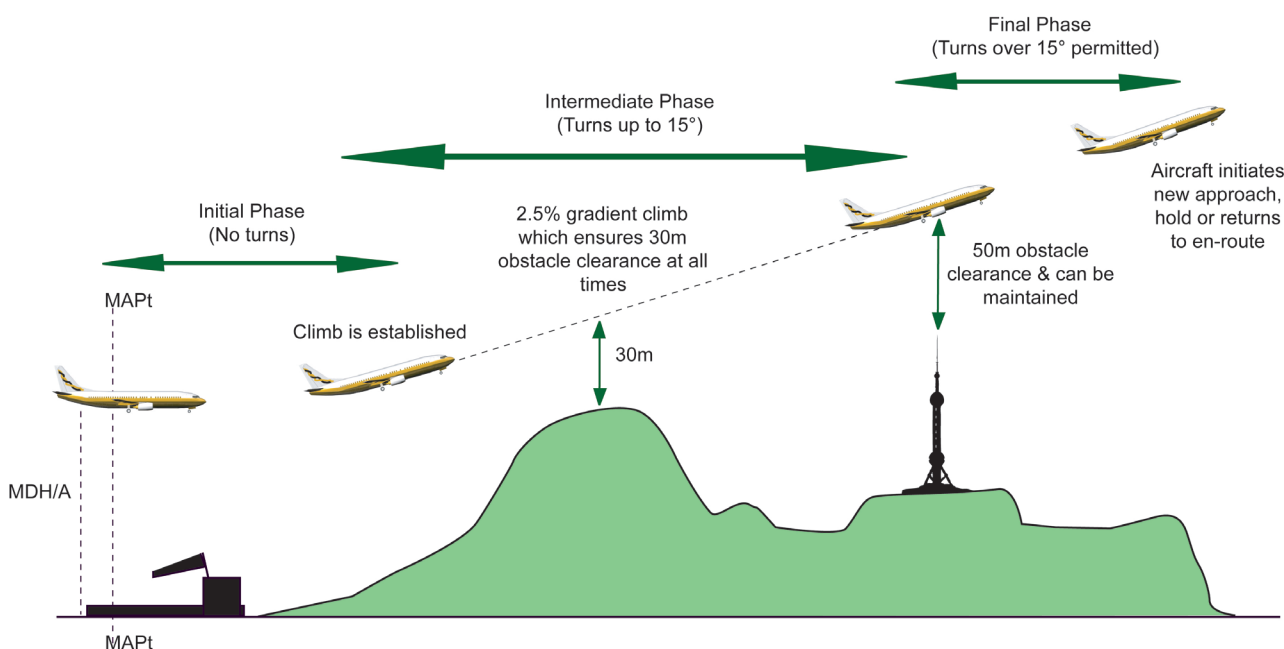

Figure 8.23: Three phases of the missed approach.

8.45 Initiating the Procedure (The Initial Phase). The initial missed approach begins at the missed approach point (MAPt) and ends where the climb is established. The manoeuvre in this phase necessitates the attention of the pilot on establishing the climb and the changes in aeroplane configuration to get the aircraft away from the ground with increasing altitude. For this reason, guidance equipment cannot normally be fully utilised during these manoeuvres and therefore no turns are specified in this phase. The missed approach is assumed to be initiated not lower than the DA/H in a precision approach, or at a specified point in non-precision approach procedure, not lower than the MDA/H. When the MAPt is defined by reference to a navigational facility or a fix (for instance the middle marker), the distance from the FAF to the MAPt is normally published as well, and may be used for timing to the MAPt. In all cases where timing is not to be used, the procedure is to be annotated "timing not authorised for defining the MAPt". The MAPt may be defined in a procedure as:

- The point of intersection of the glide path with the applicable DA/H
- A navigational facility
- A fix
- A specified distance from the FAF.

8.46 Navigation. If, upon reaching the MAPt, the required visual reference is not established, the procedure requires that a missed approach be initiated at once in order for protection from obstacles to be maintained. It is expected that the pilot will fly the missed approach as published. In the event that a missed approach is initiated prior to arriving at the MAPt, it is expected that the pilot will proceed to the MAPt and then follow the missed approach procedure in order to remain within the protected airspace. This does not preclude flying over the MAPt at an altitude/height higher than that required by the procedure.

8.47 Intermediate Phase. This is the phase in which the climb is continued, normally straight ahead but turns up to 15° (within the straight departure criteria) are permitted. The MOC in this segment is 30m and the segment extends to the first point where 50 m (164 ft) obstacle clearance is obtained and can be maintained. The climb gradient in this sector is 2.5% paralleling the OIS.

8.48 Final Phase. The final phase begins at the point where 50 m (164 ft) obstacle clearance is first obtained and can be maintained. It extends to the point where a new approach, holding or a return to en-route flight is initiated. Full turns may be prescribed in this phase.

PUBLISHED INFORMATION

8.49 Terminal Approach Plates. Information concerning instrument arrivals is published on Terminal Arrival Plates (usually referred to just as 'plates'). The plates shown here are the UK CAA plates for the London Luton self positioned ILS for runway 08. The design of the plate meets the requirement of ICAO Annex 4. Commercially produced plates are available (Jeppesen; Aerad etc...) and some operators produce their own. An ICAO plate will not show aerodrome operating minima as this is the responsibility of the operator to determine, not the state.

UK AIP

(10 Jun 04) AD 2-EGGW-8-1

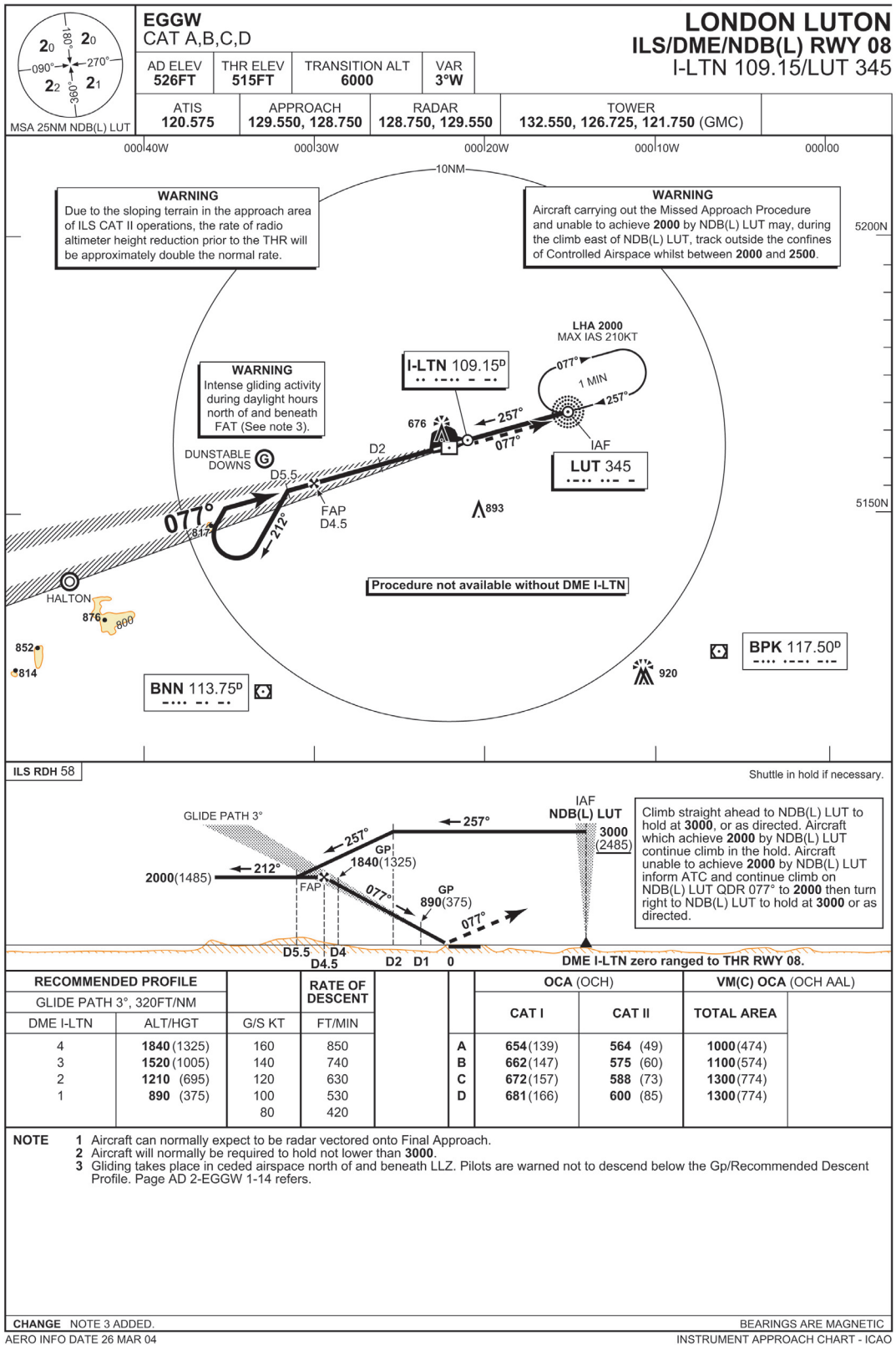

Figure 8.24:

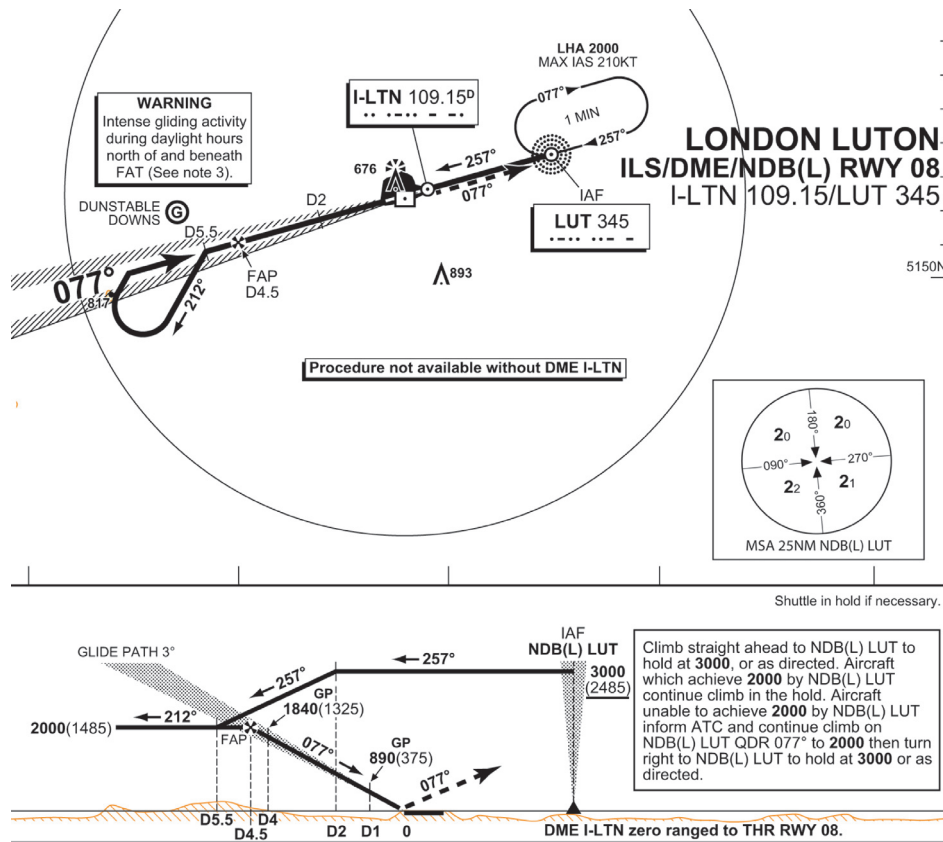

Figure 8.25:

	Obstacle Clearance Altitude/Height		OCA/H for visual manoeuvre (circling)	
	OCA (OCH)		VM(C) OCA (OCH AAL)	
	CAT I	CAT II	TOTAL AREA	
A	654(139)	564 (49)	1000(474)	
B	662(147)	575 (60)	1100(574)	
C	672(157)	588 (73)	1300(774)	
D	681(166)	600 (85)	1300(774)	

Note: This is not 'aid' dependant. It is an aerodrome characteristic

RECOMMENDED PROFILE		G/S KT	RATE OF DESCENT FT/MIN
GLIDE PATH 3°. 320 FT/NM			
DME I-LTN	ALT/HGT		
4	1840 (1325)	160	850
3	1520 (1005)	140	740
2	1210 (695)	120	630
1	890 (375)	100	530
		80	420

Note: For information and cross reference only

Figure 8.26:

RNAV APPROACH PROCEDURES BASED ON VOR/DME

8.50 Basic Assumption. RNAV procedures based on VOR/DME are non precision procedures. It is assumed that the reference facility is composed of a VOR and co-located DME equipment. Aircraft equipped with RNAV systems approved by the authority of the State of the Operator may use these systems to carry out VOR/DME RNAV approaches providing that before starting a flight it is ensured that:

- The RNAV equipment is serviceable;
- The pilot has current knowledge how to operate the equipment so as to achieve the optimum level of accuracy; and
- The published VOR/DME facility upon which the procedure is based is serviceable.

8.51 Data Insertion Errors. The procedures require a computer to handle the data and this has to be programmed with current promulgated data. This is inserted by the operator or the crew and the system has no method of checking for input errors. Therefore, the computed positional information presented ('outputted') to the crew may well contain errors induced into the system.

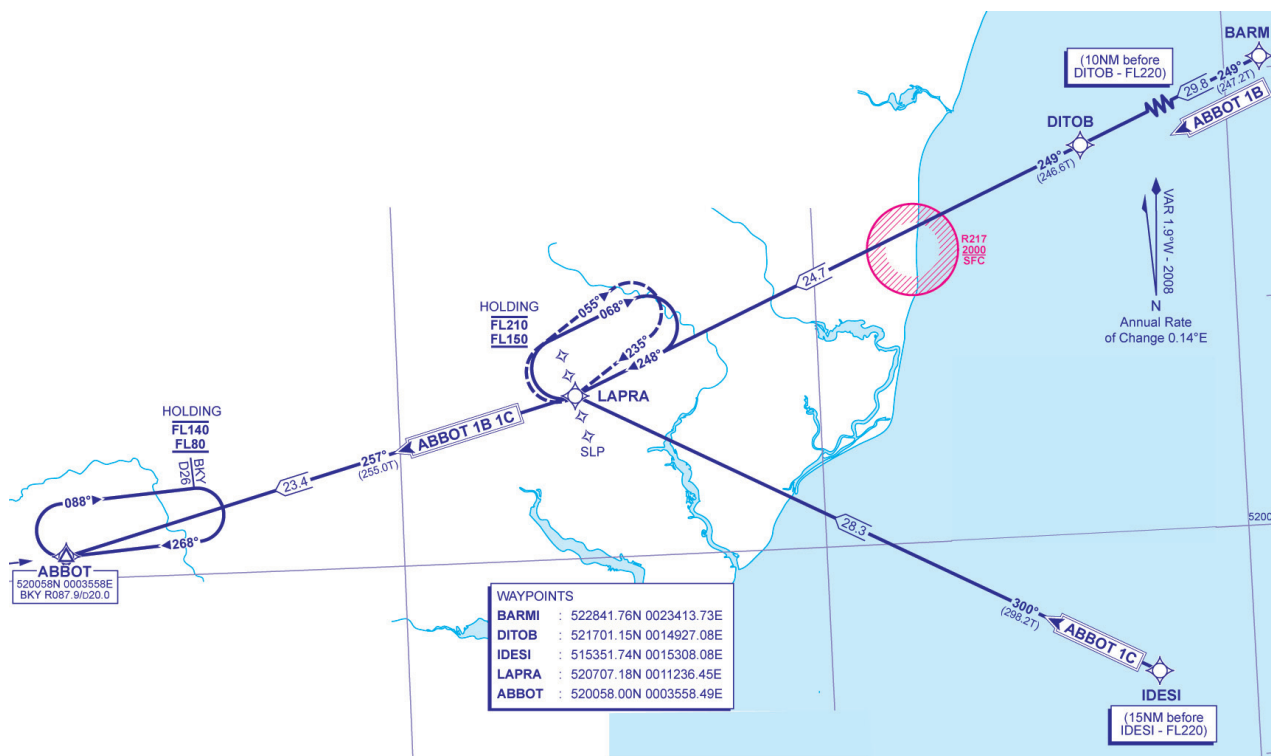

Figure 8.27:

8.52 Accuracy. The factors affecting accuracy of the VOR/DME RNAV system are:

- Ground station tolerance
- Airborne receiving system tolerance
- Flight technical tolerance
- System computational tolerance
- Distance from the reference facility

The equipment may be used when carrying out conventional (non RNAV) instrument procedures providing the procedure is monitored using the basic display normally associated with that procedure, and the tolerances for using raw data on the basic display are complied with.

QUESTIONS

1. What radius from a terminal VOR is MSA provided?
 - a. 25nm.
 - b. 10nm.
 - c. 15nm.
 - d. 15km.

 2. What is the climb gradient required during the intermediate segment of a missed approach?
 - a. 5.5%.
 - b. 2.5%.
 - c. 0.8%.
 - d. 3.3%.

 3. A precision Approach Procedure is defined as:
 - a. an approach using bearing, elevation and distance information.
 - b. an approach with a crew of at least 2 pilots trained for such operations.
 - c. an instrument approach procedure utilising azimuth and glide path information provided by an ILS or a PAR.
 - d. an approach using bearing, elevation and, optionally, distance information.

 4. The MOC in the primary area of the intermediate approach segment:
 - a. is not more than 150 m.
 - b. reduces from 300 m to 150 m.
 - c. is equal to or greater than 300 m.
 - d. is 500 m in mountainous terrain.

 5. What is the optimum distance of the FAF from the threshold?
 - a. 1 nm.
 - b. 5 nms.
 - c. 10 nms.
 - d. 15 nms.

 6. For a straight in non-precision approach, the MDA/H will be not less than:
 - a. OCH/A.
 - b. 200 ft.
 - c. 350 ft.
 - d. 400 ft.

 7. What is the maximum interception angle which is allowed to the intermediate approach segment from the initial approach segment for a non-precision approach?
 - a. 30°.
 - b. 45°.
 - c. 120°.
 - d. 15°.
-

8. An instrument approach is made up of a number of segments. How many of them are there?
- 4
 - 5
 - 3
 - 6
9. On a precision approach, where does the final approach segment start?
- DH
 - FAF
 - FAP
 - MAPT
10. On an instrument approach, part of the procedure enables the aircraft to return inbound from outbound with tracks flown being reciprocal. This is called:
- base turn.
 - procedure turn.
 - reverse procedure.
 - racetrack.
11. Which categories of aircraft fly the 45° leg of a procedure turn for 1 minute?
- A, B and C.
 - A only.
 - A and B.
 - C, D and E.
12. On an instrument approach, what is the maximum permissible descent gradient in the final approach?
- 3°.
 - 5%.
 - 6.5%.
 - 4.5°.
13. For the intermediate section of a missed approach, what is the minimum obstacle clearance?
- 30m.
 - 100m.
 - 50m.
 - 120m.
14. During an initial approach, what is the turn between the outbound track and the inbound track where the tracks flown are not reciprocal?
- Reverse turn.
 - Race track.
 - Procedure turn.
 - Base turn.

15. What are the Cat 2 ILS criteria for instrument runways?
- RVR=> 350m DH not below 100 ft.
 - RVR =>200 DH not below 100 ft.
 - RVR =>200 DH not below 200 ft.
 - RVR =>300 DH not below 200 ft.
16. When is OCH for an ILS approach complied with?
- Not more than ½ scale glide path and full scale localiser deflection.
 - Not more than ½ scale localiser deflection.
 - Not more than ½ scale glide path and localiser deflection.
 - Not more than full scale glide path and ½ scale localiser deflection.
17. What is the MOC for the intermediate missed approach segment?
- 30m.
 - 50m.
 - 120m.
 - 300m.
18. In which stage of an instrument approach do you align with the runway?
- Initial segment.
 - Final segment.
 - Arrival segment.
 - Intermediate segment.
19. What are ICAO defined instrument approaches?
- Non-precision and CAT I/II/III precision.
 - Precision in general.
 - Precision CAT I/II/III.
 - Instrument precision and CAT II/III.
20. Within what angle of the extended centre line of a runway is a non-precision approach considered to be straight in?
- 10°.
 - 15°.
 - 30°.
 - 40°.
21. What is the name of the phase of an instrument approach in which the aircraft is aligned with the runway and descent commenced?
- Final.
 - Initial.
 - Intermediate.
 - Arrival.

22. At what point does the intermediate phase of a missed approach end?
- When 30 metres obstacle clearance is attained and can be maintained.
 - When 50 metres obstacle clearance is attained and can be maintained.
 - When 75 metres obstacle clearance is attained and can be maintained.
 - When 90 metres obstacle clearance is attained and can be maintained.
23. The 45° leg of a 45/270° procedure turn for a Cat C aircraft is:
- 1 min.
 - 1 min 15 seconds.
 - 1 min 30 seconds.
 - continued until interception of the glide slope.
24. Is it permitted to fly over the Missed Approach Point at an altitude higher than MDA?
- Yes.
 - Never.
 - Sometimes.
 - It depends on the flight conditions.
25. For an instrument approach, the missed approach gradient is:
- 3%.
 - 3.3%.
 - 5%.
 - 2.5%.
26. On a precision approach (ILS), the OCH(A) is based among other standard conditions, on the vertical limits between the flight path of the wheels and the glide path antenna. For a Category C aircraft this should not be more than:
- 6 m.
 - 7 m.
 - 3 m.
 - 12 m.
27. What is the turn from outbound to inbound called where the tracks flown are not reciprocal?
- Base turn.
 - Procedure turn.
 - Reversal procedure.
 - Racetrack procedure.
28. When following an instrument procedure, the pilot must:
- calculate the track required and request ATC clearance to follow it.
 - fly the heading without wind correction.
 - adjust the track specified to allow for the wind.
 - fly the heading to make good the required track allowing for the wind.

29. Where does the initial phase of a missed approach procedure end?
- From where a new instrument approach can be commenced.
 - Where 50 ft obstacle clearance is obtained and can be maintained.
 - Where a climb is established.
 - At the missed approach point.
30. Who determines OCA/H?
- The operator.
 - The flight operations department.
 - The authority of the State.
 - The Commander.
31. What does an approach plate not include?
- OCH.
 - ILS/DME frequencies.
 - Obstacles infringing the OIS.
 - Aerodrome operating minima for the use of the aerodrome as an alternate aerodrome, if higher than normal.
32. The V_{AT} for a Category B aircraft is:
- up to 91 kts.
 - 90 to 121 kts inclusive.
 - 141 to 165 kts inclusive.
 - 91 to 120 kts inclusive.
33. OCH clearance on ILS is given, provided the accuracy flown on the localiser is within:
- $\frac{1}{4}$ scale deflection.
 - $1\frac{1}{2}$ scale deflection.
 - 1 scale deflection.
 - $\frac{1}{2}$ scale deflection.
34. Where does the initial sector of a missed approach procedure end?
- When a height of 50m has been achieved and maintained.
 - When established in the climb.
 - At the missed approach point.
 - When en-route either to the hold or departure.
35. When using a DR segment to take up an ILS instrument approach, what is the maximum length of the track that may be used to intercept the localiser?
- 10 nms.
 - 5 nms.
 - 10 minutes.
 - 5 minutes.

36. The obstacle clearance surfaces for an ILS assume a pilot localiser accuracy of:
- ¼ scale.
 - ½ scale.
 - 1 scale.
 - 1 ½ scale.
37. The abbreviation OCH means:
- obstacle clearance height.
 - obstruction/collision height.
 - obstruction clearance height.
 - obstacle confirmation height.
38. What is the descent gradient in the final segment for an ILS CAT II approach?
- Between 2.5° and 3.5°.
 - 3%.
 - 3°.
 - Up to 400 ft/nm.
39. What are the 5 segments of an instrument approach?
- Initial; Intermediate; Descent; Final; Landing.
 - Arrival; Initial; Intermediate; Final; Missed Approach.
 - Initial; Intermediate; Final; Landing; Missed Approach.
 - Arrival; Initial; Intermediate; Final; Landing.
40. The minimum sector altitude gives an obstacle clearance of 300 metres within a certain radius from the navigation aid on which the instrument procedure is based. This radius is:
- 15 nms (28 kms).
 - 30 nms (55 kms).
 - 25 nms (46 kms).
 - 20 nms (37 kms).
41. What is the minimum ground visibility for a CAT I ILS approach?
- 800m.
 - 550m.
 - 50m.
 - 550 ft.
42. Where does the initial approach segment begin in an instrument approach procedure?
- At the IF.
 - At the IAF.
 - At the FAF.
 - At the final en-route fix.

43. If the track on an instrument departure is published the pilot is expected to:
- correct for the known wind so as to stay within controlled airspace.
 - ask ATC for another heading to steer correcting for wind.
 - ignore the wind and proceed with a heading equal to the track.
 - ask ATC for permission to correct heading for wind.
44. Under which circumstances may an aircraft on a “straight in” VOR approach continue below MDA/H?
- When it seems possible to land.
 - When the aircraft is in contact with the ground but does not have the runway in sight.
 - When the aircraft has the necessary visual criteria specified by the operator.
 - When the tower is visible.
45. What is the obstacle clearance in the primary area of the intermediate approach segment while on the instrument approach?
- 300m (984 ft).
 - 450m (1,476 ft).
 - 300m (984 ft) reducing to 150m (492 ft).
 - 600m (1,968 ft).
46. What is the MOC in the primary area of the initial segment of an approach?
- At least 150m.
 - At least 300m.
 - 300m.
 - 150m.
47. When can an aircraft descend below MSA?
- 1.) The airfield and underlying terrain are visible and will remain so.
 - 2.) The aircraft is under radar control.
 - 3.) The underlying terrain is visible.
 - 4.) The aircraft is following an approach procedure.
- 1, 2 and 4.
 - 1, 3 and 4.
 - 2, 3 and 4.
 - 1, 2, 3 and 4.

ANSWERS

Question	Answer	Reference	Question	Answer	Reference
1.	A	8.3	29.	C	8.45
2.	B	8.44	30.	C	8.26
3.	C	8.5	31.	D	8.49
4.	B	8.19	32.	D	8.2
5.	B	8.21	33.	D	8.5
6.	A	8.28	34.	B	8.45
7.	C	8.18	35.	A	8.18
8.	B	8.12	36.	B	8.5
9.	C	8.23	37.	A	8.26
10.	B	8.39	38.	C	8.36
11.	C	8.40	39.	B	8.12
12.	C	8.36	40.	C	8.3
13.	A	8.19	41.	A	8.6
14.	D	8.42	42.	B	8.18
15.	A	8.6	43.	A	8.11
16.	C	8.5	44.	C	8.8
17.	A	8.47	45.	C	8.19
18.	B	8.20	46.	C	8.18
19.	A	8.4	47.	D	8.3
20.	C	8.13			
21.	A	8.20			
22.	B	8.47			
23.	B	8.40			
24.	A	8.46			
25.	D	8.44			
26.	B	8.33			
27.	A	8.42			
28.	D	8.11			

CHAPTER NINE
CIRCLING APPROACH

Contents

INTRODUCTION	179
REVISION QUESTIONS.	181
ANSWERS	184

INTRODUCTION

9.1 General. Visual Manoeuvring (Circling) (VM(C)) is the term used to describe the visual phase of flight, after completing an instrument approach, to bring the aircraft into position for landing on a runway not suitably located for a straight-in approach. Any instrument procedure (precision or non precision) may be used but the descent in the final segment will be to MDA/H for VM(C) as defined and calculated in 8.35. The procedure is defined as non precision only, despite the type of approach.

9.2 Visual Flight Manoeuvre. A circling approach is a visual flight manoeuvre keeping the runway in sight. Each circling situation is different because of variables such as runway layout, final approach track; wind and meteorological conditions. Therefore there can be no single procedure that will cater for every situation. After initial visual contact, the basic assumption is that the runway environment (the runway markings, lights or approach lighting etc...) will be kept in sight while at MDA/H for circling. The recommended maximum speeds for VM(C) are specified in the table on page 159.

9.3 The Visual Manoeuvring (Circling) Area. VM(C) is only permitted in the VM(C) area. This is determined for each category of aircraft by drawing arcs related to aircraft manoeuvring speed centered on each runway threshold and joining those arcs with tangential lines. The radius of the arcs is related to:

- Aircraft category
- Speed (for each category)
- Wind speed (assumed as 25kts throughout the turn)
- Bank angle (20° or rate 1 whichever requires less bank)

9.4 Prohibited Sector. The area may be sectored and VM(C) may be precluded from a particular sector where unrealistic MDA/H for VM(C) would otherwise exist. In this case, the published information will specify the sector and the restriction.

Visual Manoeuvring (Circling) Area

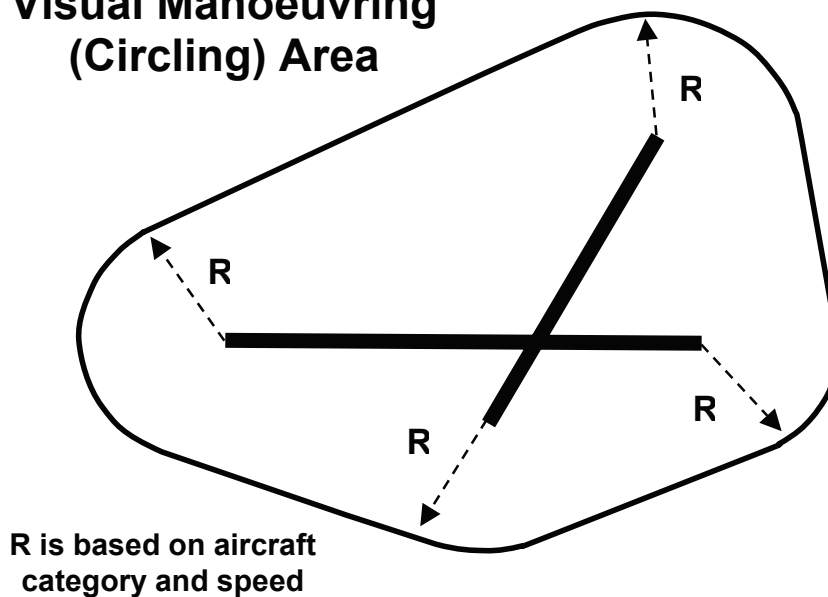

Figure 9.1:

9.5 Missed Approach While Circling. If visual reference is lost while circling to land from an instrument procedure, the missed approach specified for the instrument approach runway must be followed. It is expected that the pilot will make a climbing turn towards the landing runway and when overhead the aerodrome, the pilot will establish the aircraft climbing on the specified missed approach track.

VM(C) missed approach – fly the procedure for the instrument runway not the landing runway
Make a climbing turn towards the centre of the instrument runway and then commence the missed approach from there

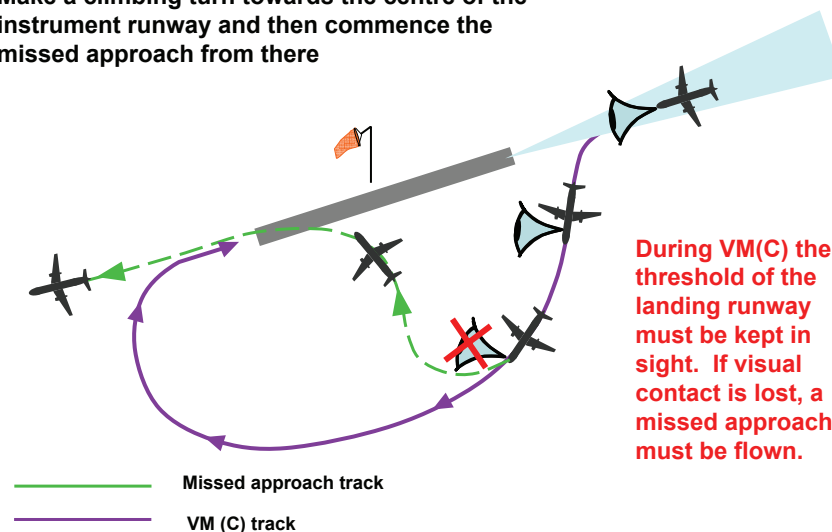

Figure 9.2:

9.6 OCA/H for Visual Manoeuvring (Circling). The table below shows the OCA/H for visual manoeuvring (circling) and the minimum visibility for the procedure. Beware, these are the ICAO data and are different from the JAR-OPS data which is required learning for Operational Procedures.

Aircraft Category	Obstacle Clearance M (ft)	Lowest OCH above aerodrome elevation m (ft)	Minimum visibility km (nm)
A	90 (295)	120 (394)	1.9 (1.0)
B	90 (295)	150 (492)	2.8 (1.5)
C	120 (394)	180 (591)	3.7 (2.0)
D	120 (394)	210 (689)	4.6 (2.5)
E	150 (492)	240 (787)	6.5 (3.5)

Figure 9.3: OCA/H for visual manoeuvring (Circling).

QUESTIONS

1. During Visual Manoeuvring (Circling) what is the maximum airspeed for a Cat B aircraft?
 - a. 120 kt.
 - b. 125 kt.
 - c. 150 kt.
 - d. 135 kt.

2. When the VM(C) area has been established the obstacle clearance altitude /height (OCA/H) is determined for:
 - a. all categories of aircraft, and it is the same for all of them.
 - b. each category of aircraft and it may be different for each of them.
 - c. only for categories A and B aircraft.
 - d. only for categories C, D and E aircraft.

3. It is permissible to eliminate from consideration a particular sector where a prominent obstacle exists in the visual manoeuvring (circling) area outside the final approach and missed approach areas. When this option is exercised, the published procedure:
 - a. prohibits a circling approach to the affected runway.
 - b. prohibits circling within the sector in which the obstacle exists.
 - c. permits circling only in VMC.
 - d. recommends that circling is not carried out in the affected sector.

4. A circling approach is:
 - a. a flight manoeuvre performed only under radar vectoring.
 - b. a flight manoeuvre where visual contact with the underlying terrain is maintained.
 - c. a visual manoeuvre keeping the runway in sight.
 - d. a visual manoeuvre only conducted in IMC.

5. The term used to describe the visual phase of flight after completing an instrument approach, to bring an aircraft into position for landing on a runway which is not suitably located for a straight in approach, is called:
 - a. a contact approach.
 - b. the aerodrome traffic pattern.
 - c. visual manoeuvring (circling).
 - d. a visual approach.

6. If visual reference is lost while circling to land from an instrument approach, it is expected that the pilot will make a climbing turn towards the:
 - a. landing runway.
 - b. MAPt.
 - c. FAF.
 - d. final missed approach track.

7. If contact is lost with the runway on the downwind leg of a circling manoeuvre, what actions should be taken?
 - a. Turn towards the inner marker for the runway in use, maintaining circling altitude.
 - b. Initiate a missed approach.
 - c. Turn 90° towards the runway and wait for visual contact to be re-established.
 - d. If you other visual cues, continue the approach.

8. Visual circling for a category B aircraft is to be conducted in visibility not less than:
 - a. 1500m.
 - b. 1600m.
 - c. 2800m.
 - d. 5000m.

ANSWERS

Question	Answer	Reference
1.	D	8.2
2.	B	9.6
3.	B	9.1
4.	C	9.2
5.	C	9.1
6.	A	9.5
7.	B	9.5
8.	C	9.6

CHAPTER TEN
HOLDING PROCEDURES

Contents

HOLDING PROCEDURES187
ENTRY SECTORS189
ATC CONSIDERATIONS190
OBSTACLE CLEARANCE192
QUESTIONS194
ANSWERS196

HOLDING PROCEDURES

10.1 Introduction. Holding is the equivalent to temporary parking areas for aeroplanes. Clearly (unless you are flying a rotorcraft) you cannot stop, but you can remain (hold) in the vicinity of a radio navigation facility for as long as is required (fuel permitting!). Providing you can fly the aeroplane accurately and navigate with reference to a radio navigation aid (VOR, NDB) or a fix position, holding is a feasible option for losing time. Indeed, in bad weather or at times of peak traffic flow, you will be lucky to get a 'straight in' approach. All instrument arrivals start from a holding pattern established at the IAF. In a holding pattern, aircraft are 'stacked' up, one on top of another with the necessary vertical separation applied (1 000 ft). As the bottom aircraft departs the holding pattern to fly the approach procedure, the others above are 'shuttled' (descended in the stack) to a lower level one at a time.

10.2 Deviation warning. It must be noted that deviations from the in-flight procedures for holding incur the risk of excursions beyond the perimeters of holding areas established in accordance with the provisions of PANS OPS. The procedures described in PANS OPS relate to right turn holding patterns. For left turn holding patterns, the corresponding entry and holding procedures are symmetrical with respect to the inbound holding track.

10.3 Shape and Terminology. The shape of holding patterns and the associated terminology is shown below. A standard holding pattern has starboard (right) turns. If port turns are required, the approach plate will be annotated to indicate the fact. A left hand pattern is a mirror image of the standard pattern.

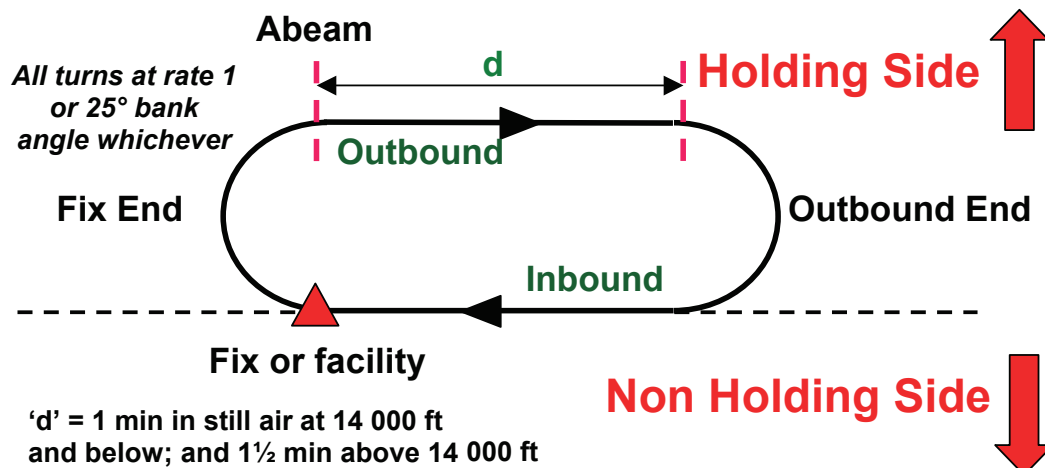

Figure 10.1: Holding pattern terminology.

10.4 Flying the Pattern. In flying the holding pattern described, all turns are to be made at an angle of bank of 25° or at a rate of 3° per second (rate 1), whichever requires the lesser bank. All the procedures depict tracks and pilots should attempt to maintain the track by making allowance for known wind by applying corrections both to heading and timing during entry and while flying the holding pattern. Outbound timings begin over or abeam the fix whichever occurs later. If the abeam position cannot be determined, start the timing when the turn to outbound is completed. The outbound track should be flown for 1 minute at 14,000ft and below and 1½ minutes above 14,000ft. If the outbound leg is based on a DME distance, the outbound leg terminates as soon as the limiting DME distance is attained. If for any reason, a pilot is unable to conform to procedures for normal conditions, ATC should be informed as soon as possible. Holding patterns are to be flown at speeds given in the table below.

Levels ¹	Normal Conditions	Turbulence Conditions
up to 4250m (14 000 ft) inclusive	425 km/h (230 kt) ² 315 km/h (170kt) ⁴	520 km/h (280 kt) ³ 315 km/h (170 kt) ⁴
above 4250 m (14 000 ft) to 6100 m (20 000 ft) inclusive	445 km/h (240 kt) ⁵	520 km/h (280 kt) or
above 6100 m (20 000 ft) to 10,350 m (34 000 ft) inclusive	490 km/h (265 kt) ⁵	0.8 Mach, whichever is less ³
above 10,350 m (34 000ft)	0.83 Mach	0.83 Mach

Notes:

- 1 The levels tabulated represent altitudes or corresponding flight levels depending upon the altimeter setting in use.
- 2 When the holding procedure is followed by the initial segment of an instrument approach procedure promulgated at a speed higher than 425 km/h (230 kt), the holding should also be promulgated at this higher speed wherever possible
- 3 The speed of 520 km/h (280 kt) (0.8 Mach) reserved for turbulence conditions shall be used for holding only after prior clearance with ATC, unless the relevant publications indicate that the holding area can accommodate aircraft at these flight holding speeds
- 4 For holdings limited to CAT A and B aircraft only.
- 5 Wherever possible, 520 km/h (280 kt) should be used for holding procedures associated with airway route structures.

Figure 10.2: Holding speeds.

ENTRY SECTORS

10.5 Introduction. There are three methods of joining a holding pattern based on the heading of the aircraft as it approaches the holding fix. Based upon this heading, three sectors are defined with specific procedures appropriate to each. Between each sector there is a 5° 'flexibility' area either side of the defining heading within which the pilot has the choice of applicable joining procedure. The three sectors are illustrated below. For ease of definition the entry procedures below relate to a standard (right hand) pattern.

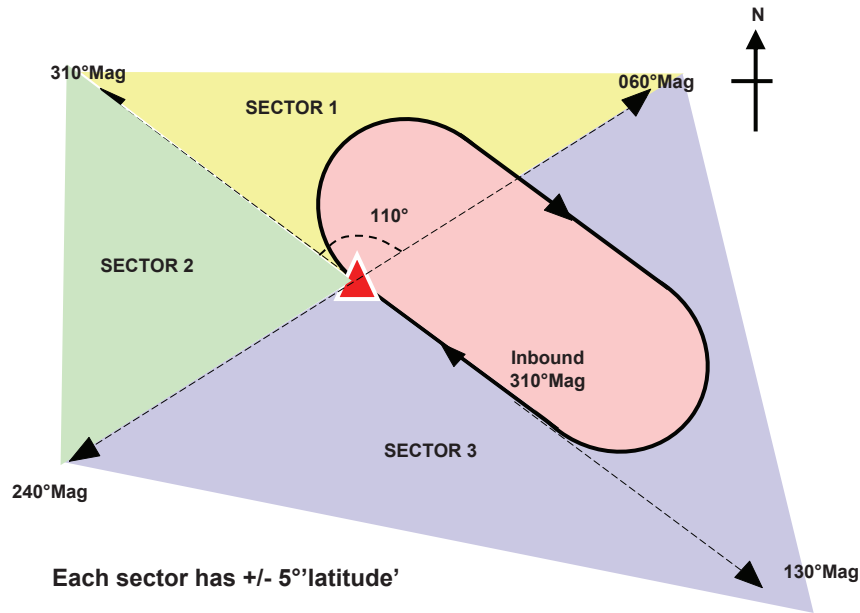

Figure 10.3:

10.6 Sector 1 (Parallel Entry) Procedure. Having reached the fix, the aircraft is turned left onto an outbound heading to make good a track reciprocal to the stated inbound holding track. This is maintained for the appropriate period of time relating to the altitude of the aircraft, and then the aircraft is turned left to return to the fix. On the second time over the fix, the aircraft is turned right to follow the holding pattern.

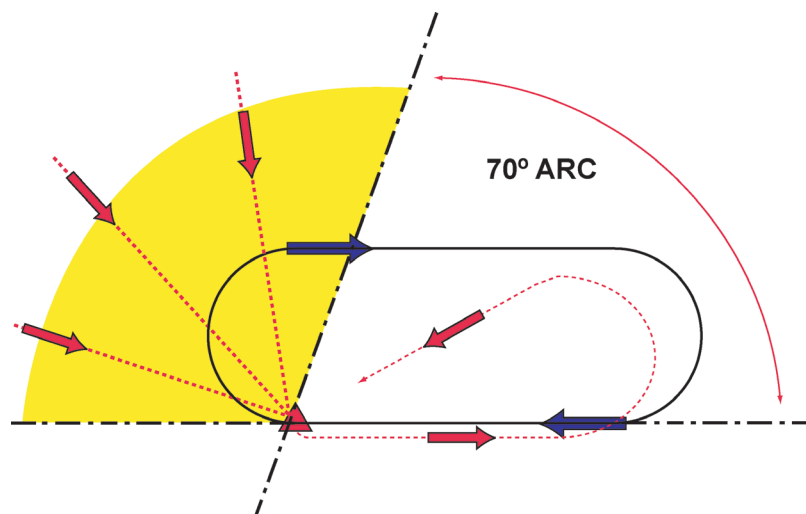

Figure 10.4:

10.7 Sector 2 (Offset Entry) Procedure. Having reached the fix, the aircraft is turned onto the heading to make good the track diverging 30° left of the reciprocal of the inbound holding track. This is maintained for the appropriate period of time relating to the altitude of the aircraft, and then the aircraft is turned right onto the holding track to return to the fix. On the second time over the fix, the aircraft is turned right to follow the holding pattern.

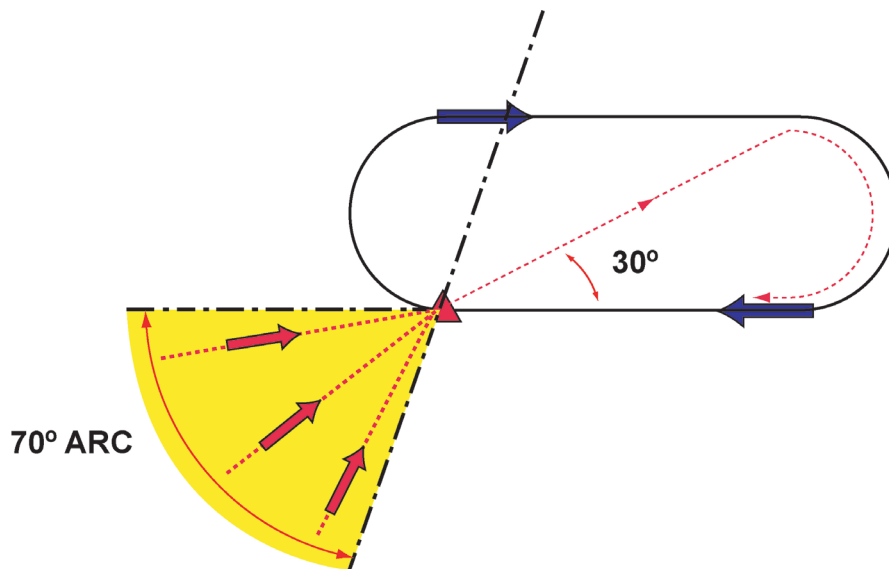

Figure 10.5:

10.8 Sector 3 (Direct Entry) Procedure. Having reached the fix, the aircraft is turned right to follow the holding pattern.

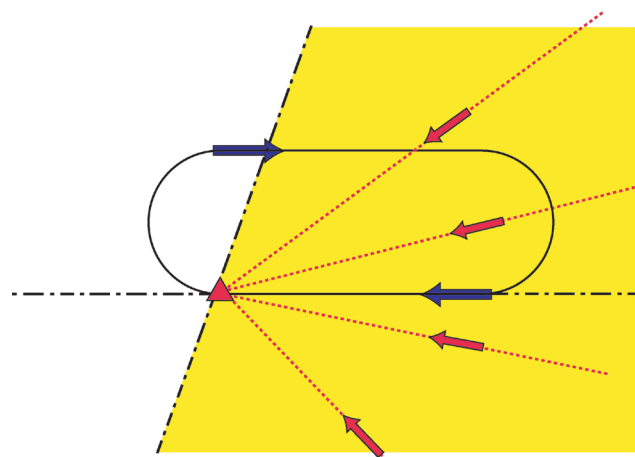

Figure 10.6:

ATC CONSIDERATIONS

10.9 Clearance to Join. As the holding pattern will be in controlled airspace and used for controlled flights, ATC (usually the approach controller) will pass an ATC clearance to the pilot with instructions to take up the holding pattern. The clearance will specify the location of the hold to be used, details of the holding pattern (unless routinely published), the holding level and any special requirements.

“G-CD hold at OX FL50 expected approach time 1020”
“Hold OX FL50 1020 G-CD”

Followed by:

“Oxford Approach G-CD is established in the hold at FL50”

The pilot is required to ensure that the aircraft is level at the holding level at least 5 nm before reaching the holding fix. The clearance will be acknowledged and the ATCO will not expect to hear from the pilot again until the aircraft has completed the joining procedure and is established in the holding pattern.

10.10 Descending in the Hold. When the level below is vacant, the ATCO will re-clear the pilot to the lower level. The pilot will acknowledge the clearance and immediately commence descent.

Note: Shuttle is a climbing or descending manoeuvre in a holding pattern.

“G-CD shuttle in the hold to FL40”
“Leaving FL50 descending to FL40 G-CD”

Followed by:

“G-CD level FL40”

10.11 Departing the Hold. At the appropriate time, the ATCO will instruct the pilot to commence the instrument procedure. It is usual to leave a holding pattern at the fix, but where radar is used the Approach Radar controller may vector the aircraft from any position in the holding pattern. Typically a clearance would be as follows:

“G-CD advise when ready to commence the procedure”

“Ready to commence the procedure G- CD”

“G-CD set the Oxford QNH 1003, clear NDB/DME approach runway 01, report turning inbound at 2000ft”

“1003 set clear NDB/DME runway 01 wilco G-CD”

Under certain circumstances (timed approaches) the ATCO will clear the aircraft to depart the holding pattern at a specific time to commence the procedure. In this case, the pilot should adjust the holding pattern leg lengths to depart the pattern from overhead the holding fix as close as possible to the stated clearance time.

OBSTACLE CLEARANCE

10.12 Holding Area. The instrument procedure designer will ensure that the MOC (300m or 600m in mountainous terrain), is applied throughout the holding area. This will include the holding pattern and any necessary adjacent airspace that would be used during a joining procedure. The size of the holding area will depend upon the nature of the pattern, the type of aircraft using the hold, adjacent airspace requirements and maximum holding altitude. Surrounding the holding area a buffer zone, 5 nm wide, is established within which decreasing MOC is applied from full MOC at the boundary with the holding area, to zero at the extremity.

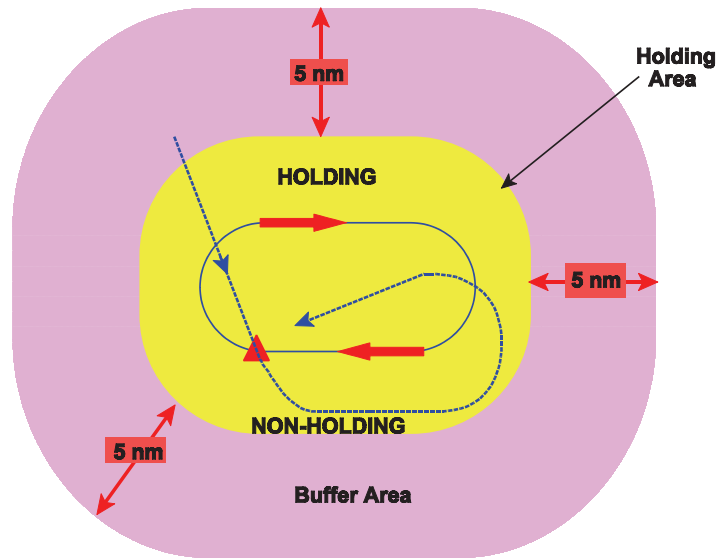

Figure 10.6:

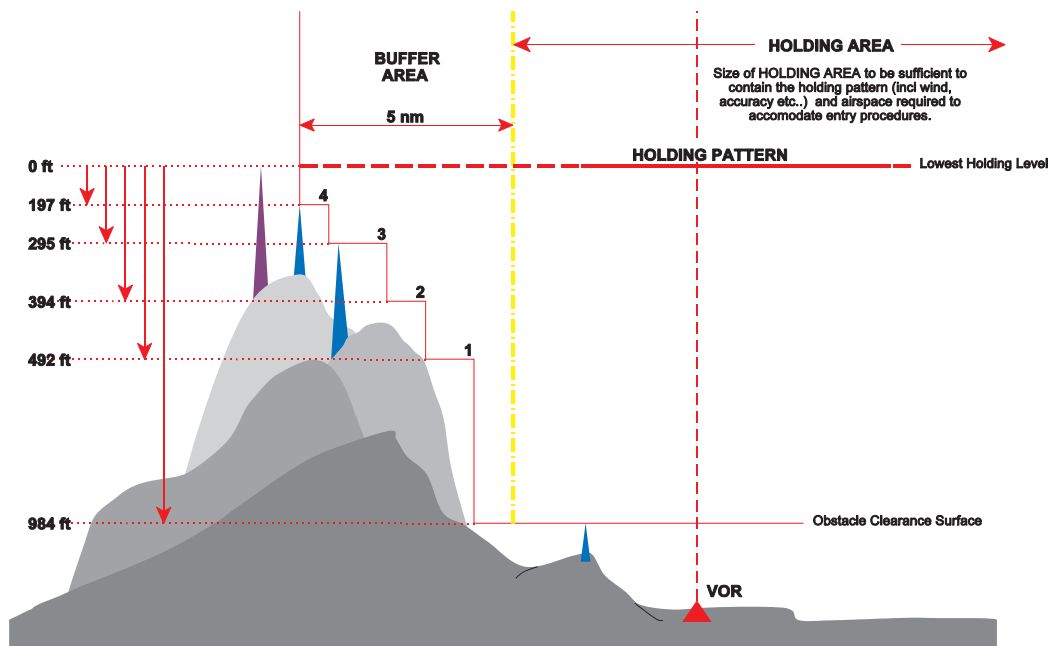

Figure 10.6:

QUESTIONS

1. A procedure to alter level in a holding pattern is known as:
 - a. shuttle.
 - b. procedure turn.
 - c. base turn.
 - d. racetrack.

2. Unless otherwise published or informed by ATC, after entering a holding pattern all turns are made:
 - a. to the left.
 - b. to the left then right.
 - c. to the right.
 - d. procedure turn right then left.

3. In a holding pattern turns are to be made at:
 - a. rate of turn = 3° /sec.
 - b. rate of turn = 3° /sec or 20° bank angle whichever is less.
 - c. rate of turn = 3° /sec or 25° bank angle whichever is less.
 - d. 25° bank angle.

4. What is the longest time you can fly the 30° offset leg of a joining procedure?
 - a. $1\frac{1}{2}$ minutes.
 - b. $2\frac{1}{2}$ minutes.
 - c. 3 minutes.
 - d. 30 seconds.

ANSWERS

Question	Answer	Reference
1.	A	10.10
2.	C	10.3
3.	C	10.4
4.	A	10.4

CHAPTER ELEVEN

ALTIMETER SETTING PROCEDURES

Contents

ALTIMETER SETTING PROCEDURES	197
BASIC CONCEPTS.	197
ALTIMETER SETTING OBJECTIVES	197
TRANSITION.	199
PHASES OF FLIGHT	201
QUESTIONS	203
ANSWERS	206

ALTIMETER SETTING PROCEDURES

BASIC CONCEPTS

11.1 Introduction. In order to ensure separation and to make sure that when flying an instrument procedure the aircraft is actually at or above the procedure design minimum altitude, it is essential that the aircraft altimeter sub scale is correctly set to the appropriate reference pressure. History is littered with accidents caused by incorrect altimeter setting and despite the best intentions of the Air Traffic Controllers, the basic responsibility remains with the pilot to ensure that whatever he/she does with an aircraft, it must be safe.

11.2 Terrain Avoidance. During instrument departure or arrival procedures the aircraft must be flown according to the published flight profile. Until the aircraft is at or above a 'safe in all cases' altitude, the altimeter must be referenced to mean sea level so that the pilot knows exactly how high the aircraft is. All obstacles shown on approach and departure plates are referenced to sea level and likewise, all altitudes required by the procedures are also referenced to sea level. As sea level pressure (QNH) varies geographically and the terrain avoidance problem is geographic in nature, the reference setting must be a local QNH.

11.3 Lowest Useable Flight Level. This is the flight level that corresponds to or is immediately above the established minimum flight altitude.

11.4 ATC Separation. Once above the 'safe in all cases' altitude, the problem ceases to be terrain avoidance and becomes avoidance of other air traffic. In this case it essential that all aircraft have at least one altimeter referenced to the same sub scale setting so that a standard separation can be applied regardless of the sea level pressure. According to ICAO ISA the average barometric pressure is 1013.25 hPa and this (when rounded down to 1013 hPa) is defined as the Standard Pressure Setting (SPS).

ALTIMETER SETTING OBJECTIVES

11.5 Objectives. The two main objectives of altimeter setting procedures are to:

- Provide adequate terrain clearance during all phases of flight especially departure and arrival.
- Provide adequate vertical separation between aircraft

11.6 Altimeter Sub-Scale settings. There are three altimeter sub scale settings that can be applied at any aerodrome. These are:

11.7 QNH. This is the observed barometric pressure at an aerodrome adjusted in accordance with the ISA pressure lapse rate to indicate the pressure that would be observed if the observation was carried out at sea level. If QNH is set on the altimeter sub-scale, the altimeter would read aerodrome elevation at touchdown.

11.8 QFE. This is the observed barometric pressure at an aerodrome which if set on the altimeter sub-scale, the altimeter would read zero at touchdown.

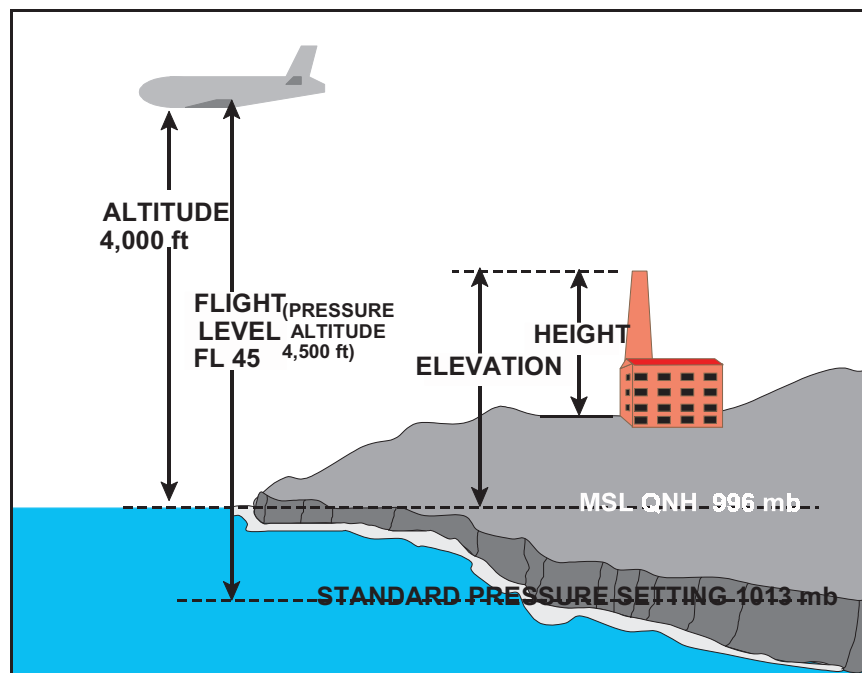

Figure 11.1:

11.9 QNE. A situation can occur where the QNH is below the lowest altimeter sub-scale setting. For instance, if the altimeter sub-scale will not read below 940 hPa and the QNH is 935 hPa it would appear that the altimeter is useless. If however, the altimeter sub scale is set to a standard setting (e.g. 1013hPa) then it would be possible to calculate what the altimeter would read at touchdown where the QNH is 930 hPa and the altimeter subscale is set to 1013 hPa using the ICAO ISA. Assume that the aerodrome elevation is 100ft AMSL. On touchdown the altimeter will read:

$$1013 - 930 = 83 \text{ (amount of pressure wound on)}$$

$$83 \times 27 \text{ ft (ISA interval)} = 2,241 \text{ ft} + 100 \text{ ft} = 2,341 \text{ ft.}$$

In this case, 2341ft is the QNE. A pilot would be instructed by the ATCO:

“G-CD set 1013 land with QNE 2340”

There is a popular misconception amongst pilots that QNE is 1013hPa. When used as a reference as opposed to a QNH, 1013hPa is defined a standard pressure setting (SPS). Therefore QNE is what the altimeter will read at touchdown with SPS set.

TRANSITION

11.20 Definition. After take off, the altimeter setting will be changed from QNH to SPS at some point. Likewise in the descent to land, the altimeter will be set to QNH from SPS at some point. The process that allows this to be done safely and at a logical point is called transition. This requires the altitude (or FL) at which this is done to be specified. The altitude above the aerodrome for change from QNH to SPS is called the **transition altitude**, and from SPS to QNH is the **transition level**. When flying below the transition altitude, the aircraft is flown at altitudes determined with reference to sea level pressure (QNH) and the vertical position is expressed in terms of altitude. Above the transition altitude, the vertical position is expressed in terms of flight levels. During a climb upon reaching the transition altitude, SPS is set and the climb continued to the desired flight level. In the descent, upon reaching the transition level, the QNH is then set and descent continued to the desired altitude.

11.21 Flight Levels. A flight level (FL) is defined as the vertical displacement of the aircraft above a constant level of barometric pressure related to 1013 hPa. Flight Level Zero (FL0) is located at the atmospheric pressure level of 1013 hPa. Subsequent flight levels are separated by a pressure interval corresponding to 500 ft in standard atmosphere. Flight levels are numbered as follows:

FL30; FL35; FL40; FL45 etc.... and FL100; FL105; FL110 etc....

11.22 Transition Altitude. This is the altitude (with QNH set) above the aerodrome at which the altimeter sub scale is reset to SPS and vertical position above that is then reported as a flight level. The transition altitude is specified for every aerodrome by the Authority of the State in which the aerodrome is located. The transition altitude shall be as low as possible but normally not less than 3,000 ft. Transition altitudes are published in the AIP and shown on charts and instrument plates. A state may specify a general transition altitude (as in the USA, 18,000 ft).

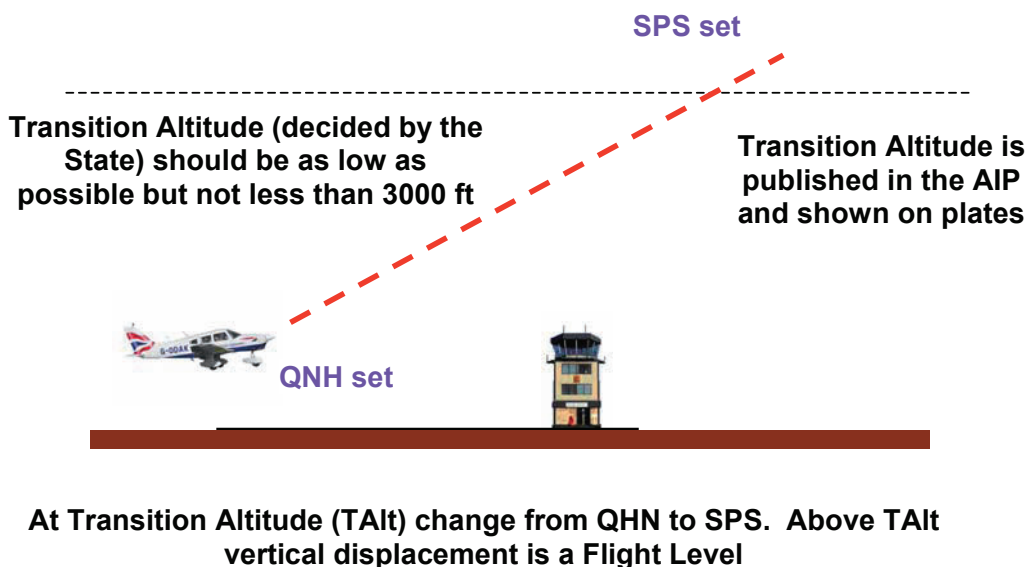

Figure 11.2: Transition altitude.

11.23 Transition Level. The transition level is the flight level at which the altimeter is reset to the aerodrome QNH and subsequent flight is reported with reference to altitude. The transition level is normally passed to aircraft in the approach and landing clearances. The transition level changes with the QNH. It is calculated by the Approach Controller at regular intervals and also when QNH changes. It is defined as the first available flight level above the transition altitude. This will be a 'rounding up' from what the altimeter is reading at the transition level with SPS set. Calculation of transition level is not required by the learning objectives.

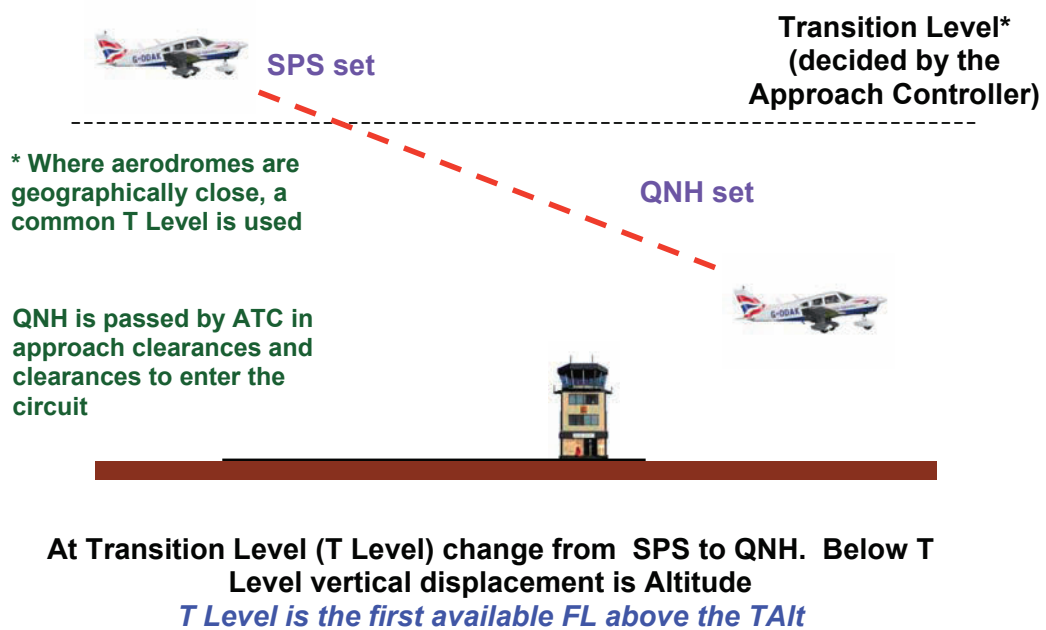
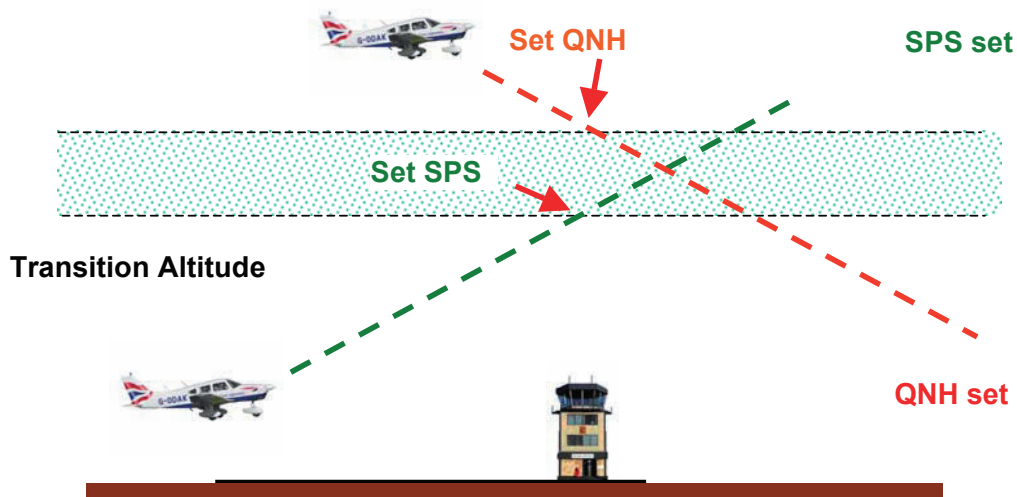

Figure 11.2: Transition level.

11.24 Transition Layer. This is the airspace between the transition altitude with SPS set and the transition level. It is usually insignificant but some states require a minimum depth to the transition layer. When ascending through the transition layer (with SPS set) vertical position is reported as a flight level and when descending through the layer with QNH set, as an altitude.



Ascending through T Layer = FL Descending through T Layer = Altitude
T Layer is the airspace between the T Alt and the T Level

Figure 11.2: Transition layer.

PHASES OF FLIGHT

11.25 What should be set? The QNH should be passed to an aircraft in the taxi clearance prior to take-off. When flying en-route below the transition altitude, the vertical position of the aircraft is reported as altitude (QNH set). When outside of the ‘vicinity’ of the departure aerodrome, QNH from another (closer) aerodrome will be required and set. In the UK we have a system of regional pressure settings (RPS) which cover this case without reference to en-route aerodrome QNH. In the USA when flying cross-country, the pilot will need to contact ATC at ‘local’ aerodromes and update the altimeter setting regularly. This will allow determination of terrain clearance with an acceptable degree of accuracy. When en-route and above the transition altitude, the aircraft level is reported as a flight level. When approaching an aerodrome to land, the QNH will be passed to aircraft in clearances to enter the traffic circuit. Normally, vertical position is reported as a flight level until reaching the transition level in the descent, however, after an approach clearance has been issued, reference should then be made in terms of altitude with the QNH set. This is intended to apply primarily to turbine aircraft for which an uninterrupted descent from high altitude is desirable.

11.26 Use of QFE. If a pilot decides to remain in the aerodrome traffic circuit (the visual circuit) throughout the flight, then the altimeter may be set to QFE.

11.27 Multiple Altimeters. If the aircraft has more than one altimeter the law requires that one altimeter must be set to QNH.

11.28 Pilot/Operator Procedures. Pilots and operators are required to plan the route and, complying with the rules of a state and the general flight rules, are to select an appropriate IFR or VFR flight level for the flight. In selecting flight levels for a flight, those selected:

- Should ensure adequate terrain clearance at all points along the route;
 - Should satisfy ATC requirements
- and
- Should be compatible with the table of cruising levels in Chap. 6

The serviceability and accuracy of the altimeter should be confirmed prior to the commencement of a flight. With knowledge of the aerodrome elevation in the case of QNH, the altimeter should be set to either QNH or QFE. The instrument should then be vibrated (avoiding tapping the glass) to ensure that the instrument has reacted to the mechanical adjustment of setting the sub-scale. A serviceable altimeter will indicate:

- The height of the altimeter above the reference point (QFE)
- or
- The elevation of the position of the aeroplane plus the height of the altimeter above the ground (QNH);

11.29 Altimeter Accuracy. Altimeters are to be checked for correct operation within the following tolerances:

- Plus or minus 60 ft (20 m) for a test range between 0 - 30,000 ft
- or
- Plus or minus 80 ft (28 m) for a test range between 0 - 50,000 ft

11.30 Approach and Landing. Before commencing an approach to an aerodrome, the pilot is to obtain the transition level. Before descending below the transition level, the latest QNH for the aerodrome is to be obtained. (This does not preclude a pilot using QFE for terrain clearance purposes during the final approach to a runway.) ATC may clear an aircraft to be operated using QNH when above the transition level if so required for the purpose of descent in accordance with a prescribed procedure (i.e. not for level flight). When an aircraft which has been given clearance as number one to land is using QFE to complete the approach, OCH is to be established with reference to height above the aerodrome datum for that portion of the flight. On approach plates all vertical displacement is shown as both AMSL and AGL in the following form: **2000** (1485) with the AMSL figure in bold type and the AGL figure in parenthesis. This is a standard format and is used in all publications.

QUESTIONS

1. What should be the minimum transition altitude?
 - a. 3,000 ft.
 - b. 1,000 ft.
 - c. 1,500 ft.
 - d. 2,000 ft.

2. Determination of the Transition Level is the responsibility of:
 - a. the Authority of the State.
 - b. the ATC Authority.
 - c. Approach Control office or the aerodrome Control Tower.
 - d. Area Control.

3. When making an approach, when should a pilot change his altimeter sub scale setting from standard to aerodrome setting, unless otherwise authorised by ATC?
 - a. Transition altitude.
 - b. Transition level.
 - c. At 3,000 ft above sea level or 1,000 ft AGL, whichever is higher.
 - d. When within the transition layer.

4. What is the transition level?
 - a. The first available flight level above the transition altitude.
 - b. The highest flight level available below the transition altitude.
 - c. The top of the ATZ.
 - d. The level at which 1013 is set.

5. When during the approach should the reported aerodrome altimeter setting be set?
 - a. When passing 3,000 ft AMSL or 1,000 ft AGL.
 - b. When passing the transition level.
 - c. When passing the transition altitude.
 - d. Within the transition layer.

6. The vertical position of an aircraft at or below the transition altitude will be reported as:
 - a. flight level.
 - b. whatever the pilot chooses.
 - c. altitude.
 - d. height.

7. In the vicinity of an aerodrome that is going to be used by the aircraft, the vertical position of the aircraft shall be expressed as:
 - a. flight level at or below the transition level.
 - b. flight level at or below the transition altitude.
 - c. altitude above sea level at or below the transition altitude.
 - d. altitude above sea level at or above the transition altitude.

8. The pilot of a departing aircraft flying under IFR shall change the altimeter setting from QNH to SPS when passing:
 - a. transition level.
 - b. when specified by ATC.
 - c. transition altitude.
 - d. transition layer.

9. Transition from altitude to flight level, and vice-versa, is done:
 - a. at transition level during the climbs and at transition altitude in the descent.
 - b. only at transition altitude.
 - c. only at transition level.
 - d. at transition altitude during the climbs and at transition level in the descent.

10. During flight through the transition layer the vertical position of the aircraft should be reported as:
 - a. altitude above mean sea level during the climb.
 - b. flight level during descent.
 - c. either altitude above mean sea level or flight level during the climb.
 - d. altitude above mean sea level during descent.

11. Whilst flying through the transition layer the vertical position of the aircraft should be reported as:
 - a. altitude.
 - b. height.
 - c. flight level.
 - d. it depends upon what is set on the altimeter.

ANSWERS

Question	Answer	Reference
1.	A	11.22
2.	C	11.23
3.	C	11.23
4.	A	11.23
5.	B	11.23
6.	C	11.20
7.	C	11.20
8.	C	11.22
9.	D	11.20
10.	D	11.24
11.	D	11.24

CHAPTER TWELVE

PARALLEL OR NEAR-PARALLEL RUNWAY OPERATION

Contents

SIMULTANEOUS OPERATION ON PARALLEL OR NEAR-PARALLEL RUNWAYS	209
MODES OF OPERATION	209
SAFETY	214
RUNWAY SPACING	215
QUESTIONS	218
ANSWERS	220

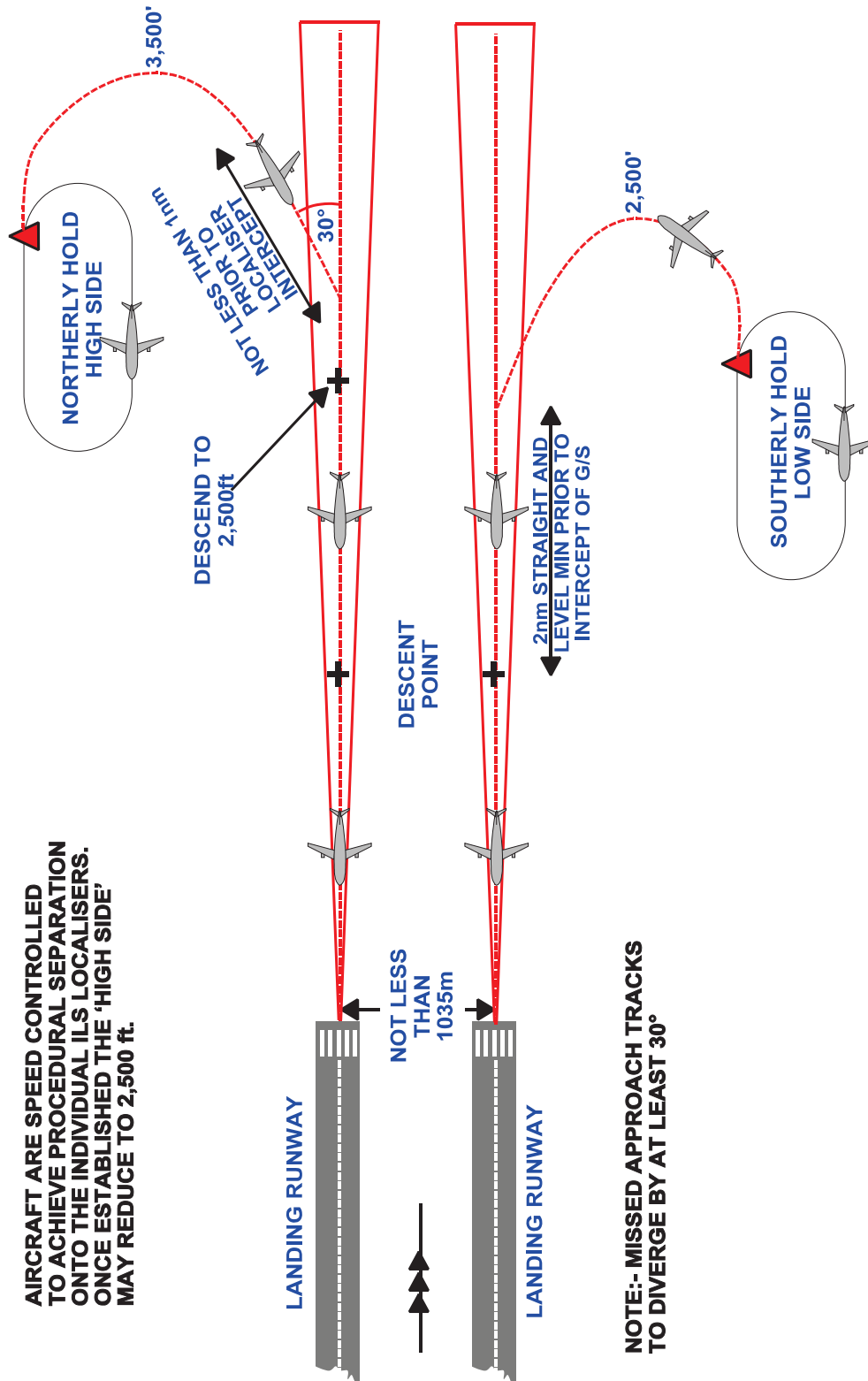

Figure 12.1: Mode 1 - Independent parallel approaches.

SIMULTANEOUS OPERATION ON PARALLEL OR NEAR-PARALLEL RUNWAYS

MODES OF OPERATION

12.1 Introduction. The need to increase capacity at aerodromes handling IFR traffic in IMC can be met by the use of parallel or near-parallel runways. An aerodrome already having dual/parallel precision approach (ILS or MLS) runways could increase its capacity if these runways could be safely operated simultaneously and independently in IMC. There is increasing pressure on major aerodromes, like Stansted, to build a second (parallel) runway and virtually all new aerodrome constructions (e.g. Chek Lap - Hong Kong) are constructed with parallel runway configurations. It is also not uncommon for the runway arrangement to include three or even four parallel (or near parallel) runways and for all of them to be in operation together. In this section the discussion will be biased towards pure parallel runway arrangements, but the procedures are the same or similar for all other arrangements. There are a variety of modes of operation associated with parallel or near-parallel runways. All parallel runway operations require the provision and use of Radar.

12.2 Simultaneous Parallel Instrument Approaches. There are two basic modes of operation possible:

12.3 Mode 1: Independent Parallel Approaches: Approaches are made to parallel runways where radar separation minima between aircraft using adjacent ILS and/or MLS are not applied.

12.4 Separation. Each pair of parallel approaches will have a 'high' side and a 'low' side to provide vertical separation until aircraft are established inbound on the respective ILS localiser course. The high side will be 300m (1,000 ft) above the low side. Before vertical separation can be reduced below 300m (1,000 ft), both aircraft on a simultaneous parallel approach must be established on the ILS localiser centre line or MLS final approach track. Once the 300m (1,000 ft) separation is reduced, the radar controller will issue instructions if the aircraft deviates significantly from the localiser course.

12.5 Mode 2: Dependent Parallel Approaches: Approaches are made to parallel runways where radar separation minima between aircraft using adjacent ILS and/or MLS are applied. Regardless of the weather conditions, all approaches are to be radar monitored with radar controllers specifically detailed for that duty only. Dedicated discrete RTF frequencies are to be allocated to the radar controllers. Only straight-in approaches are permitted with parallel runway operation. Track reversal procedures are not permitted). During vectoring to intercept the localiser the maximum interception angle permitted is 30° and a minimum of 1 nm straight and level flight is required before localiser intercept. Vectoring is also to ensure that the localiser track is intercepted and flown for at least 2 nm before glide path intercept. Until the aircraft is established on the localiser, the reduced radar separation will be 3 nm.

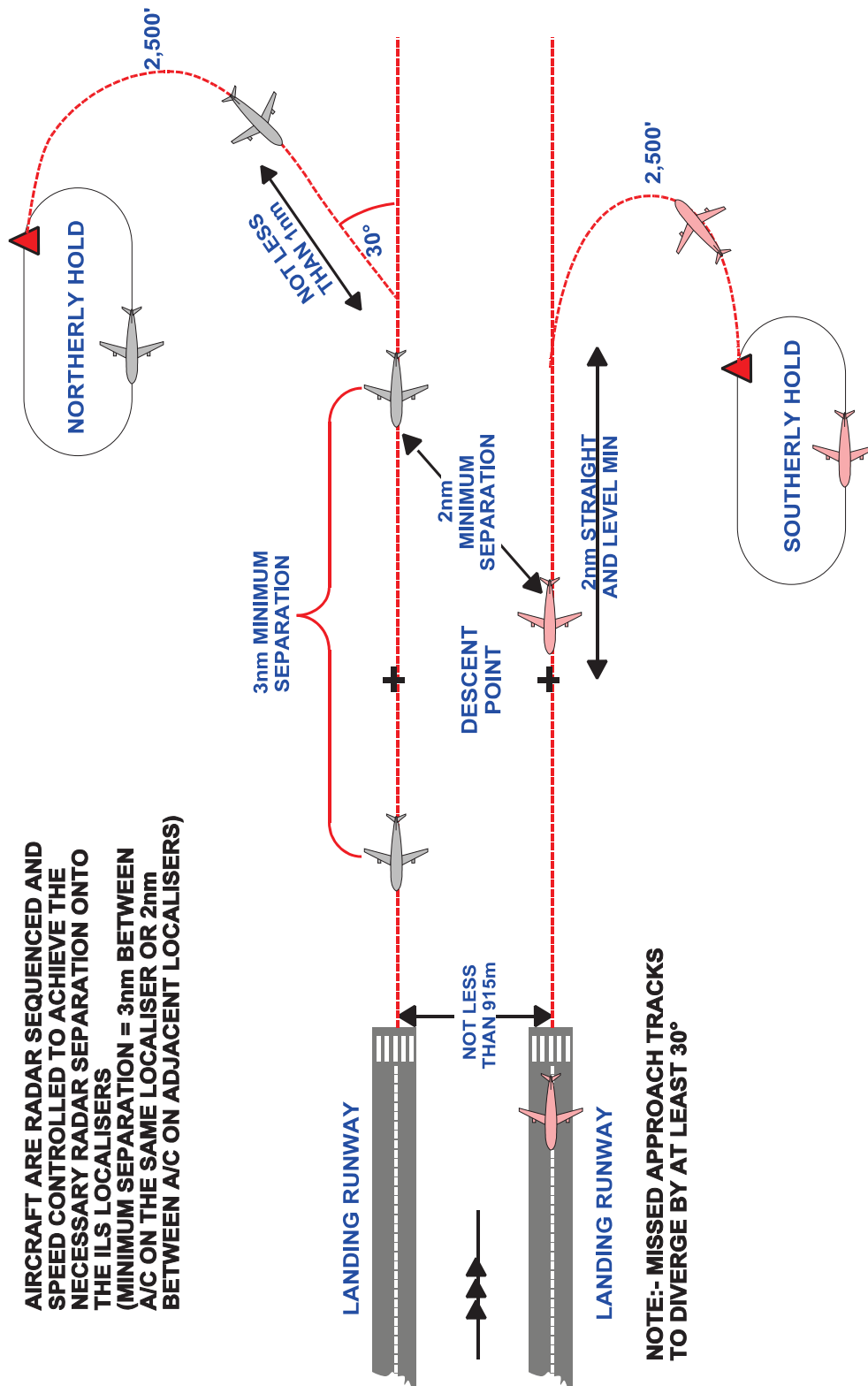

AIRCRAFT ARE RADAR SEQUENCED AND SPEED CONTROLLED TO ACHIEVE THE NECESSARY RADAR SEPARATION ONTO THE ILS LOCALISERS (MINIMUM SEPARATION = 3nm BETWEEN A/C ON THE SAME LOCALISER OR 2nm BETWEEN A/C ON ADJACENT LOCALISERS)

NOTE:- MISSED APPROACH TRACKS TO DIVERGE BY AT LEAST 30°

Figure 12.2: Mode 2 - Dependent parallel approaches.

12.6 Mode 3: Simultaneous Instrument Departures. This operation is known as Mode 3 Independent Parallel Departures. It involves simultaneous departures for aircraft departing in the same direction from parallel runways. All departing traffic must be identified by radar at a distance of not more than 1nm from DER. All departure tracks must diverge by a minimum of 15° immediately after take-off.

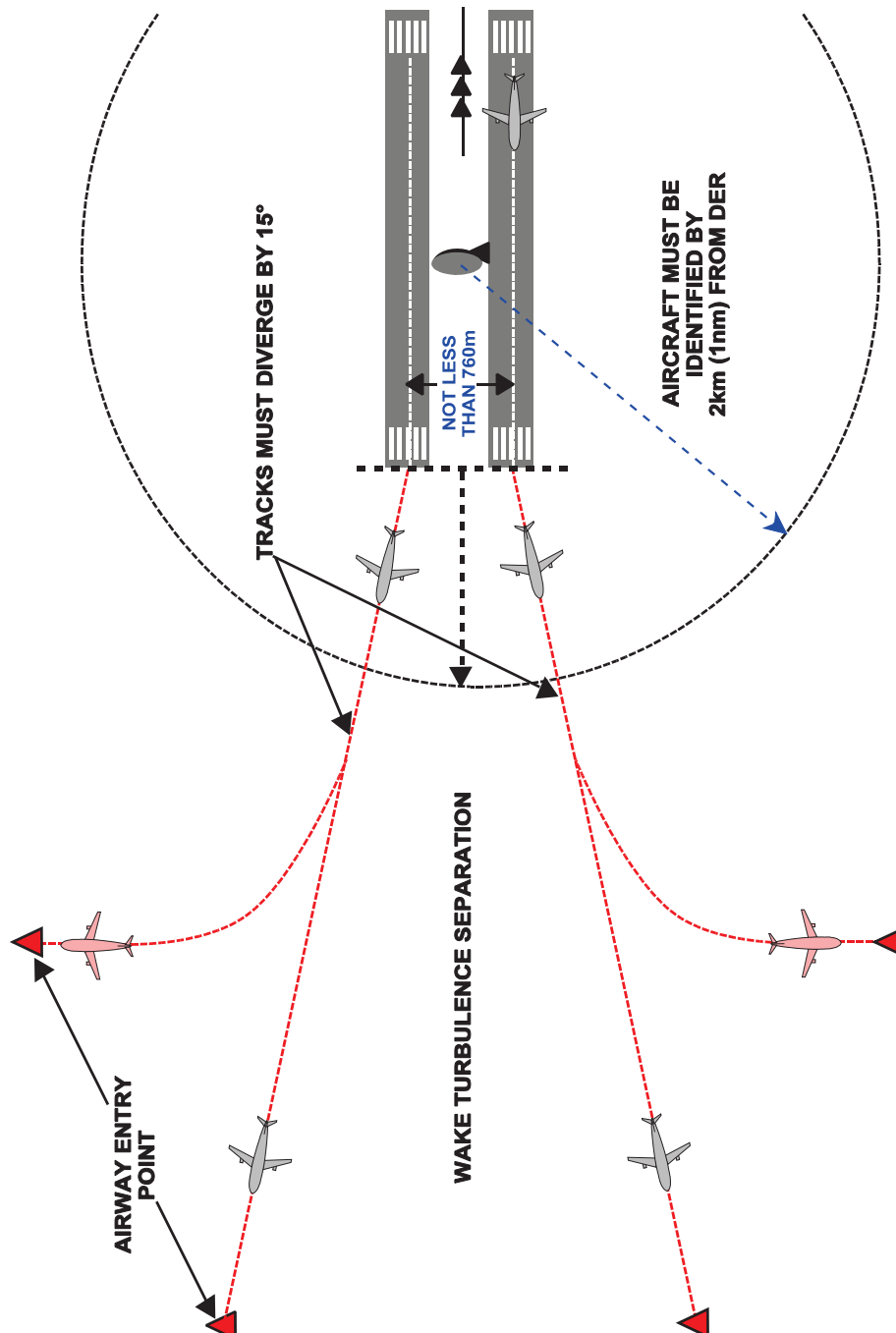

Note: When the minimum distance between two parallel runways is less than the specified value for wake turbulence separation considerations for departing aircraft, the runways are considered to be a single runway and therefore a simultaneous dependent parallel departure mode is not used.

Figure 12.3: Mode 3 - Simultaneous instrument departures.

12.7 Mode 4: Segregated Departures/Arrivals: This operation is known as Mode 4 Segregated Parallel Operations. In this mode, one runway is used exclusively for approaches and the other runway is used exclusively for departures. This is the mode of operation at London Heathrow.

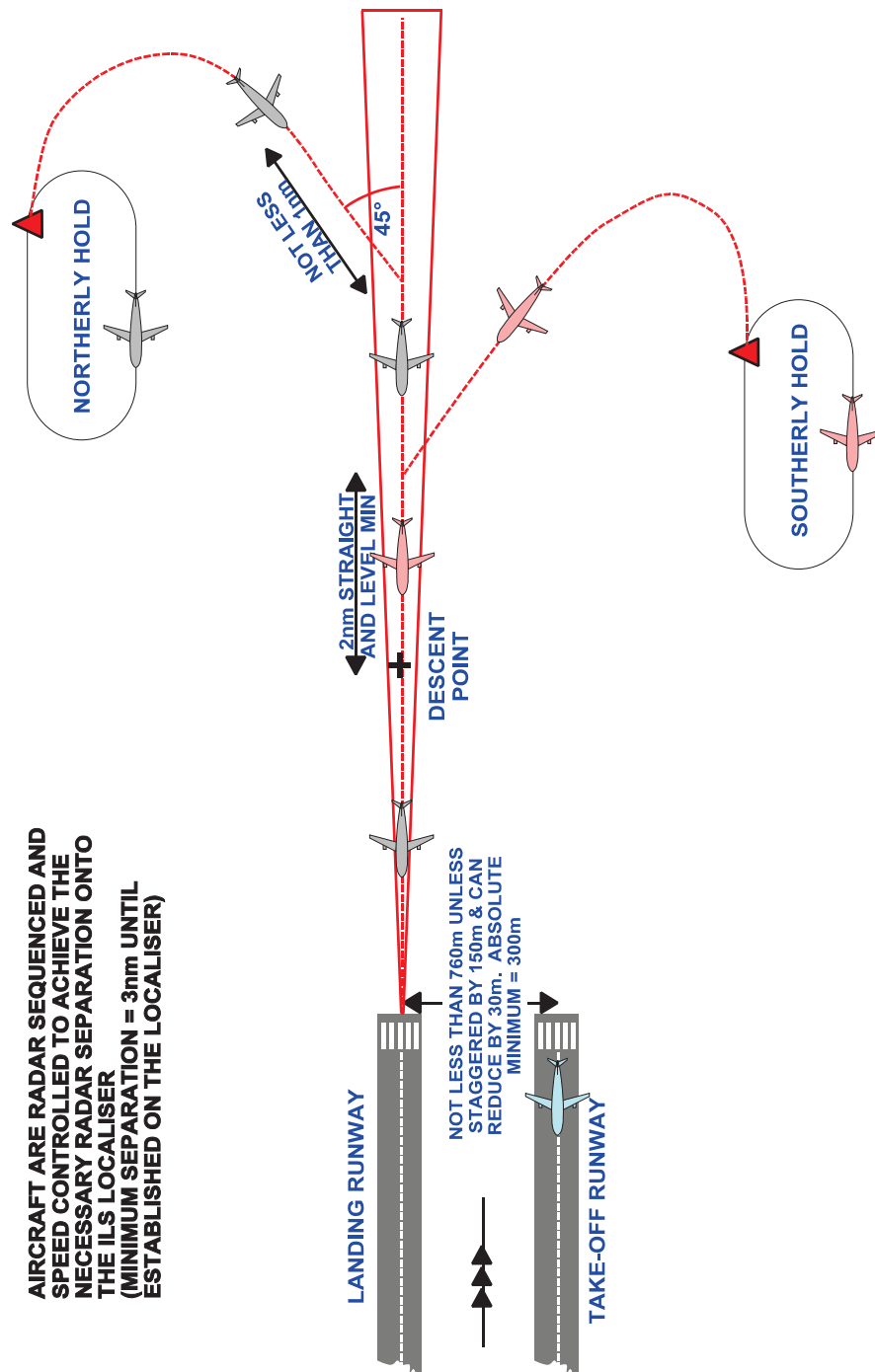

Figure 12.4: Mode 4 - Segregated departures/arrivals.

12.8 Semi-mixed Operations. In essence, the option for the use of parallel runways is totally flexible and a situation may exist where one runway is used exclusively for departures, while the other runway accepts a mixture of departures and approaches, or vice versa. There may also be simultaneous parallel approaches with departures interspersed on both runways. In effect, semi-mixed operations may be permutations of the four basic modes (above). Most North American major aerodromes operate some kind of semi-mixed operations.

SAFETY

12.9 Radar Monitoring. For all parallel runway operations, radar surveillance (or in some cases, control) must be provided. Without radar, parallel runway operations are suspended and single runway operations resumed.

12.10 Approach Operations. Due to the real estate limitations of aerodromes, it is inevitable that the spacing between parallel runways will not be sufficient to permit normal ATC separation standards to be applied. However, whatever is implemented must be safe and provide separation immediately something goes wrong. Normally, ATC separation is provided either vertically or horizontally and is usually based on the accuracy of navigation of the aircraft. If the accuracy of navigation can be improved then the separation standard can be reduced, in other words, separation can be traded off against accuracy of navigation. For parallel approach operations, vertical and horizontal separation standards are overruled once the aircraft concerned are established on the localiser centre line. Mode 1 is described as independent and implies that what happens on one runway is totally independent of what is happening on the other. Mode 2 (dependant) does roughly the same but with the addition of radar separation longitudinally and laterally of approaching aircraft, making what happens on one runway dependant upon what is happening on the other. Effectively for both modes, there are two arrival aerodromes albeit very close together.

12.11 Normal Operating Zone (NOZ). This is applicable to Mode 1 operations and is airspace of defined dimensions extending either side of an ILS localiser course (or an MLS final approach track centre line) within which an aircraft operating normally on the ILS would be positioned. Remember - the protected zone is encompassed by half scale deviation of the CDI and is the required accuracy of ILS navigation. Only the inner half of the NOZ is taken into account in independent parallel approaches.

12.12 No Transgression Zone (NTZ). In the context of Mode 1 independent parallel approaches, this is a corridor of airspace of defined dimensions located centrally between the two extended runway centre lines. Penetration of the NTZ by an aircraft requires controller intervention immediately to manoeuvre a threatened aircraft on the adjacent approach, out of the way. Normally this would require a turn away from the other aircraft and an immediate climb to MSA (or as per the Missed Approach Procedure). Once the threatened aircraft is safe, the controller will attempt to assist the other aircraft regain the approach or carry out the missed approach procedure. It is a requirement that the NTZ must be at least 610m wide.

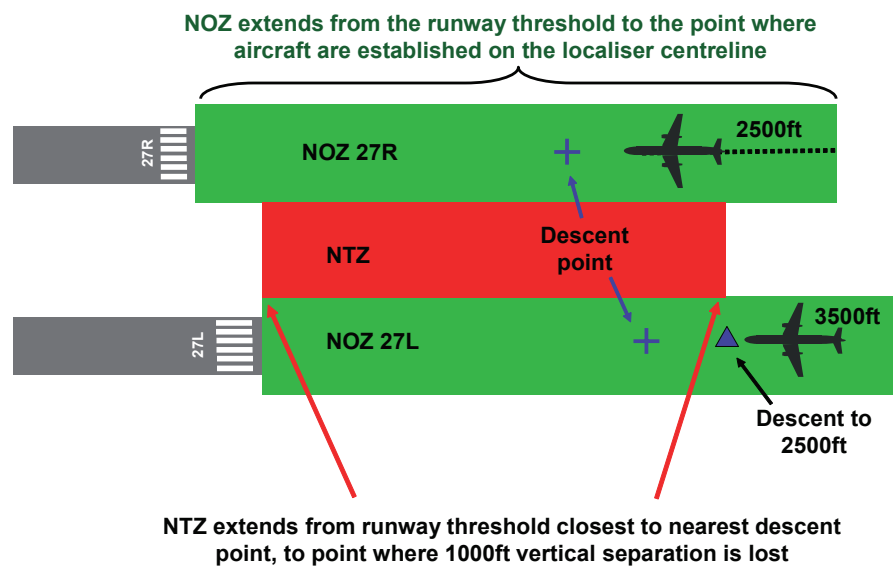
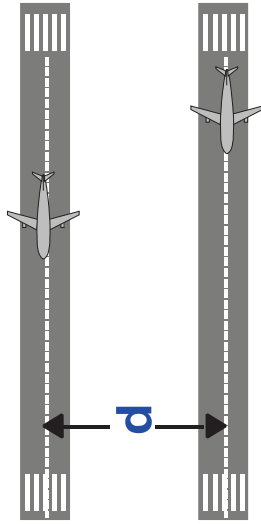

Figure 12.5: No transgression zone.

12.13 Missed Approach. Simultaneous parallel operations require the missed approach track and departure tracks to diverge by a minimum of 30°. When turns are prescribed to establish divergence, pilots are to commence turns as soon as practicable.

RUNWAY SPACING

12.14 Minimum Spacing of Parallel Runways. The worst case is where the runway thresholds (or the normal rotation points) are adjacent. This means that two approaching aircraft for instance, will always be at the same altitude when at the same distance from touchdown. If, however, the thresholds are 'staggered' then a degree of vertical separation is introduced (likewise for departing aircraft). This situation permits closer spacing of runways (30m reduction or increment for every 150m of overlap) as is the case for the new runway at Manchester. The diagram below illustrates the requirements for spacing of parallel runways. The student should know that the minimum spacing for Mode 1 operations is 1035m, for Mode 2 it is 915m and for Modes 3 and 4 it is 760m.



**PARALLEL INSTRUMENT RUNWAYS
SIMULTANEOUS USE**

- d = 1035m FOR INDEPENDENT PARALLEL APPROACHES (MODE 1)
- d = 915m FOR DEPENDENT PARALLEL APPROACHES (MODE 2)
- d = 760m FOR INDEPENDENT PARALLEL DEPARTURES (MODE 3)
- d = 760m FOR SEGREGATED PARALLEL OPERATIONS (MODE 4 -see below)

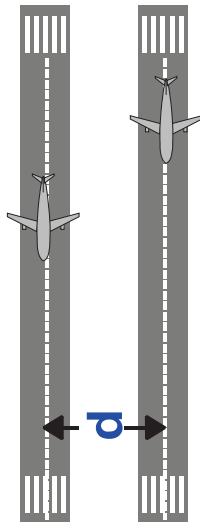

**PARALLEL NON-INSTRUMENT (VISUAL)
RUNWAYS SIMULTANEOUS USE**

- CODE 3 OR 4; d = 210m
- CODE 2, d = 150m
- CODE 1, d = 120m

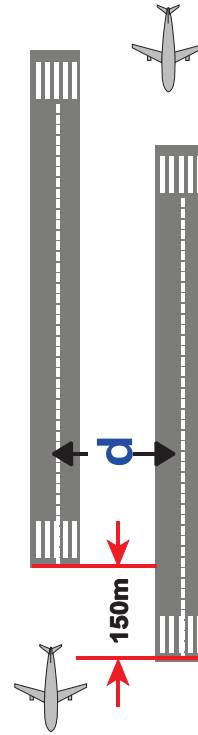

SEGREGATED PARALLEL OPERATIONS

'd' SHOULD BE INCREASED BY 30m FOR EACH 150m THAT THE DEPARTURE RUNWAY THRESHOLD IS STAGGERED TOWARDS THE ARRIVING AIRCRAFT.

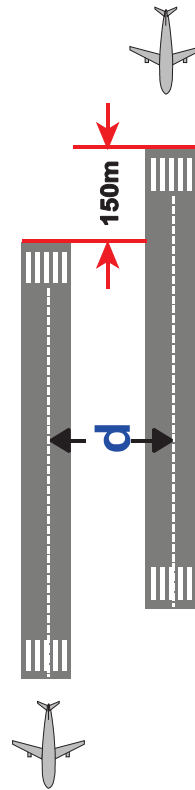

SEGREGATED PARALLEL OPERATIONS

'd' MAY BE REDUCED BY 30m FOR EVERY 150m THAT THE THRESHOLD OF THE ARRIVAL RUNWAY IS STAGGERED TOWARDS THE ARRIVING AIRCRAFT.

Figure 12.6:

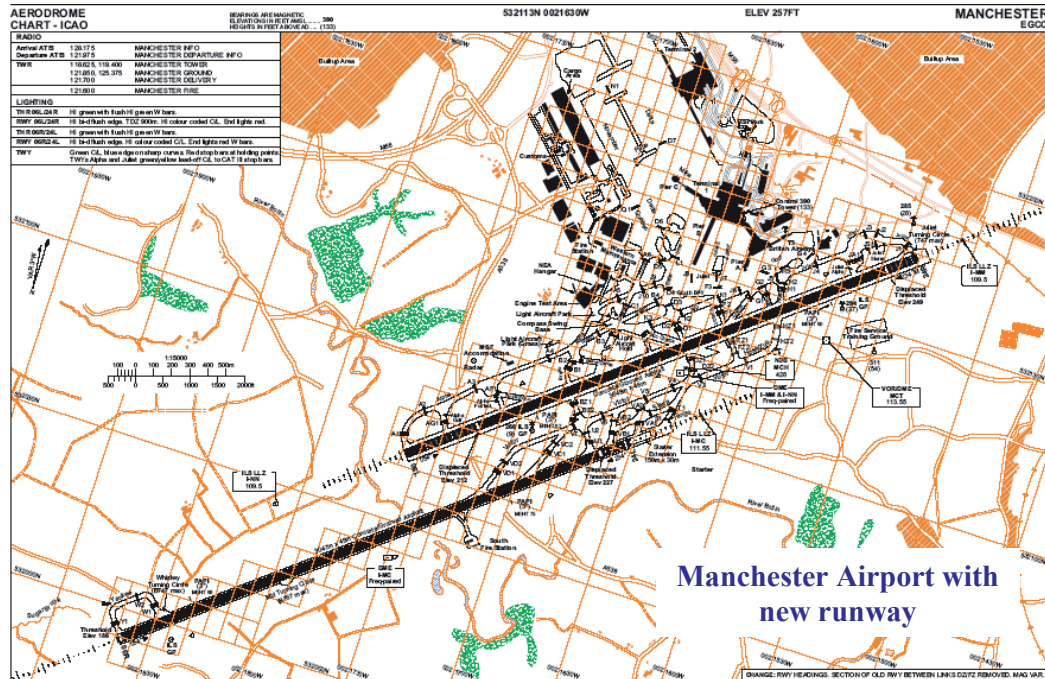

Figure 12.7:

12.15 Wake Turbulence Considerations. The full implications of Wake Turbulence are covered in other subjects and later in these notes under the umbrella of ATC we will discuss wake turbulence separation. However, the use of parallel runways introduces problems concerning wake turbulence from aircraft using adjacent runways and this is a major limitation to the flexibility that parallel runway ops facilitate. Effectively, if the spacing between runways is less than 760m or the flight paths of departing or arriving traffic cross at the same altitude (or within 1,000 ft below the higher level) then wake turbulence separation must be applied.

QUESTIONS

1. Independent parallel approaches may be conducted to parallel runways provided that:
 - a. the missed approach track for one approach diverges by at least 20° from the missed approach track of the adjacent approach.
 - b. the missed approach track for one approach diverges by at least 25° from the missed approach track of the adjacent approach.
 - c. the missed approach track for one approach diverges by at least 45° from the missed approach track of the adjacent approach.
 - d. the missed approach track for one approach diverges by at least 30° from the missed approach track of the adjacent approach.

2. Dependent parallel approaches may be conducted to parallel runways provided that the missed approach track for one approach diverges by:
 - a. at least 45° from the missed approach track of the adjacent approach.
 - b. at least 25° from the missed approach track of the adjacent approach.
 - c. at least 15° from the missed approach track of the adjacent approach.
 - d. at least 30° from the missed approach track of the adjacent approach.

3. When independent parallel approaches are being conducted to parallel runways and vectoring to intercept the ILS localiser course, the vector shall be such as to enable the aircraft to be established on the ILS localiser course in level flight for:
 - a. at least 1.5 nm prior to intercepting the ILS glide path.
 - b. at least 2.5 nm prior to intercepting the ILS glide path.
 - c. at least 2.0 nm prior to intercepting the ILS glide path.
 - d. at least 3.0 nm prior to intercepting the ILS glide path.

4. For parallel runways the missed approach tracks must diverge by:
 - a. 15° .
 - b. 30° .
 - c. 45° .
 - d. 25° .

5. Where independent parallel runway operations are in progress, what is the maximum permitted interception angle to intercept the localiser?
 - a. 20° .
 - b. 25° .
 - c. 30° .
 - d. 45° .

6. The minimum distance between parallel runway centre lines for Simultaneous Independent Parallel Approaches (Mode 1) is:
 - a. 915 m.
 - b. 760 m.
 - c. 300 m.
 - d. 1035 m.

7. A minimum vertical separation shall be provided until aircraft are established inbound on the ILS localiser course and/or MLS final approach track. This minimum is, when independent parallel approaches are being conducted:
 - a. 300 m.
 - b. 200 m.
 - c. 150 m.
 - d. 100 m.

8. A minimum radar separation shall be provided until aircraft are established inbound on the ILS localiser course and/or MLS final approach track. This minimum is, when independent parallel approaches are being conducted:
 - a. 3 nm.
 - b. 5 nm.
 - c. 2 nm.
 - d. 2.5 nm.

9. Independent parallel approaches may be conducted to parallel runways provided that a no transgression zone (NTZ) of at least:
 - a. 710 m is established between extended runway centre lines and as is depicted on the radar display.
 - b. 510 m is established between extended runway centre lines and as is depicted on the radar display.
 - c. 610 m is established between extended runway centre lines and as is depicted on the radar display.
 - d. 810 m is established between extended runway centre lines and as is depicted on the radar display.

ANSWERS

Question	Answer	Reference
1.	D	12.13
2.	D	12.13
3.	C	12.3
4.	B	12.13
5.	C	12.5
6.	D	12.14
7.	A	12.4
8.	A	12.5
9.	C	12.12

CHAPTER THIRTEEN

SSR AND ACAS

Contents

SSR AND ACAS	223
SECONDARY SURVEILLANCE RADAR (SSR)	223
AIRBORNE COLLISION AVOIDANCE SYSTEM (ACAS)	225
QUESTIONS	226
ANSWERS	228

SSR AND ACAS

SECONDARY SURVEILLANCE RADAR (SSR)

13.1 Background. The technical requirements of the JAA Theoretical Knowledge syllabus for SSR, is covered in 062 Radio Navigation. However, the operation of SSR in the ATC environment is within the remit of Air Law. In the chapters of these notes concerning ATC, the use of radar will be discussed and it will be implied that where required, the radar derived information will be enhanced by the use of SSR. The modern SSR systems have been developed from the equipment used in WWII as a means of identifying 'friend' from 'foe' (IFF). The basic system was rather crude effectively giving the ground station a response from the aircraft indicating that the aircraft was fitted with the then highly secret equipment. As only 'friendly' aircraft had the equipment the radar operator could easily distinguish a friendly aircraft radar response from an enemy response. The airborne equipment was given the code name 'parrot' which explains some of the rather peculiar phraseology associated with the operation of a modern SSR system. Current SSR systems enable individual aircraft to be identified on a flight by flight basis with the additional facilities to pass data via the SSR system, indicate aircraft altitude and, using the redundant capacity of the SSR system, provide effective collision avoidance enhancement.

13.2 Carriage of Transponders. The airborne equipment is called a transponder (because it **transmits** a response to an interrogation). PANS OPS requires that where a serviceable transponder is carried in an aircraft, unless ATC instructs otherwise, it will be used at all times. Individual states may specify certain conditions where the carriage and operation of a transponder is mandatory. In either case, the operation of the equipment will be regardless of the provision of an ATC service.

13.3 Mode of Operation. The output codes of the SSR system consist of groups of 4 numbers in the range 0 - 7. The ground station (the interrogator) transmits a coded signal that prompts the aircraft transponder to reply. The overall SSR system has several different 'modes' of operation. The response will be mode Alpha with addition of mode C. In addition, the military have other modes of operation of SSR which overlap with civilian usage. In order to correctly indicate the required response code, the mode as well as code should always be specified. The pilot is to respond with the mode and code. Typically a radar controller will request the mode and code as follows:

"G-CD, squawk Alpha two one six one"

The response to this by the pilot will be (mode and code):

"Squawking Alpha two one six one G-CD"

13.4 Squawk Ident. The transponder has a facility to enable the radar controller to automatically identify the specific radar contact using SSR other than by reliance on the specific code transmission. This facility may be activated by selection of the 'Ident' feature on the transponder controller in response to a request to "squawk Ident." Pilots are not to squawk Ident except on instruction from the radar controller.

13.5 Special Codes. Because the airborne equipment can transmit any of 4096 individual coded responses, certain individual responses have been allocated specific meanings. The following special codes indicate:

- Emergency A/7700
- Radio failure A/7600
- Unlawful interference A/7500

In addition, the following reserved codes have the specific meanings:

- A/7000 Conspicuity. This is set when the aircraft is in an area where radar is used to provide ATS, but the pilot is not in receipt of a service (VFR outside CAS).
- A/2000 In the absence of any ATC direction or regional air navigation agreement (or when outside of a radar control/service area). This code is set when eastbound in the NAT region.
- A/0000 Unserviceable transponder. Set as directed by ATC.

13.6 Altitude Reporting Function (Mode Charlie). Mode Charlie encodes and transmits the aircraft altitude with reference to SPS (1013hPa). Whenever the transponder is operating, mode Charlie should also be selected. At some point during the initial communications with ATC, the pilot will be requested to “say aircraft level for Charlie.” The pilot should report the aircraft level information accurate to the nearest full 100ft. From this, the ATCO will determine the accuracy of mode Charlie data. If the mode Charlie data is within +/-300ft of the stated level, mode Charlie is deemed to be accurate.

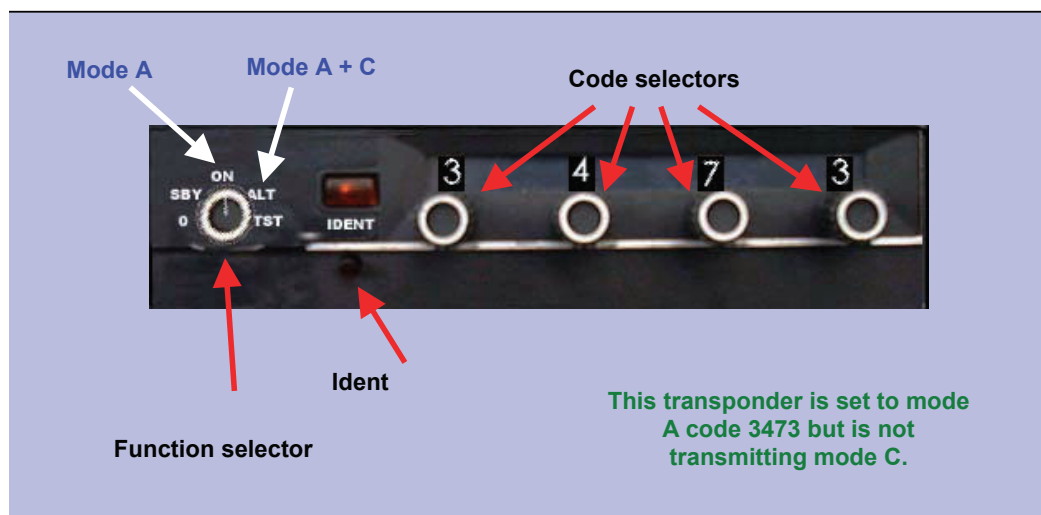

Figure 13.1:

13.7 Transponder Failure. The failure of a transponder in the air will adversely affect the quality of the ATC service provided. Whilst every effort will be made to permit the flight to continue to the destination in accordance with the filed FP, it may be that ATC clearances may be restricted. If a transponder fails before departure and it cannot be rectified, the pilot is to:

- Inform ATS as soon as possible, preferably before the submission of the FP.
- Put 'N' in item 10 for the FP form.
- Comply with the published procedures for seeking exemption from the requirements for the mandatory carriage of a transponder.
- If required by the ATS authority, proceed directly to the nearest suitable aerodrome where the transponder can be repaired.

13.8 Code Selection. The preferred method of selecting/changing a code is to first set the option switch to standby (STBY) and then select the new code. On complete, reset the option switch to ON or ALT. Modern SSR installations have two controllers (designated A and B) with a switch that selects either the A controller or the B controller. In this case, the new code would be set on the controller not in use and the switch then set to that controller.

AIRBORNE COLLISION AVOIDANCE SYSTEM (ACAS)

13.9 Background. The technical details of ACAS is covered in detail in 022 03 Warning and Recording. However, the response to the alerts generated by ACAS is a matter for consideration in Air Law. Basically, the system uses the redundant capacity of the SSR system to determine the proximity of another aircraft which is operating its SSR transponder. In areas where RVSM is applied, the use of ACAS is mandatory and operators are required to ensure compliance with the requirement.

13.10 Use of ACAS. ACAS is to be used by pilots in the avoidance of potential collisions, the enhancement of situational awareness, and the active search for (and visual acquisition of) conflicting traffic. It must be understood by pilots that the use of and the exploitation of ACAS alerts and the procedures applicable, do not relieve the pilot of the basic responsibility for the safety of the aeroplane. In all cases, the pilot will be expected to exercise his/her best judgment and full authority in choosing the best course of action to be taken.

13.11 Response to ACAS Alerts. ACAS generated alerts consist of Traffic Advisories (TAs) and Resolution Advisories (RAs). A TA is intended to alert the pilot to the possibility of an RA being generated. As such, pilots are not to manoeuvre the aircraft in response to a TA only. If an RA is generated, the pilot is to respond immediately unless in doing so the safety of the aeroplane would be jeopardized. In any case, stall warning, wind shear and GPWS alerts will have priority over ACAS. Pilots must be aware that visually acquired traffic may not be the cause of an RA and visual perception of an encounter may be misleading especially at night.

13.12 ATC. As soon as would be permitted by the workload of the flight deck crew, ATC should be notified of the RA and the direction of any deviation from the current flight plan. Once the conflict is resolved, the aircraft should be promptly returned to the requirements of the current FP and again, ATC informed. Under some circumstance, it is possible that ATC issues instructions that are unknowingly contrary to ACAS RAs. It is vitally important that ATC is notified when an ATC instruction or clearance is not being followed because it conflicts with an ACAS RA.

13.13 Determination of Aircraft Level using Mode C. ICAO defines the standards for level determination using Mode C (altitude reporting function) as generally +/- 300ft. However, most contracting states employ a higher standard, +/- 200ft. The specific ICAO standards are:

- Level occupancy: Mode C indicates the allocated level +/- 300 ft
- Maintaining a level: Mode C indicates the allocated level +/- 300 ft
- Vacating a level: Mode C indicates that the aircraft is more than 300 ft from the previously allocated level
- Passing a level: Mode C indicates that the aircraft is within 300 ft of a specified level in the climb or descent
- Reaching a level: Mode C indicates that the aircraft is within 300 ft of the allocated level at the completion of a climb or descent

QUESTIONS

1. When acknowledging mode/code setting instructions, pilots shall:
 - a. read back only the code to be set.
 - b. read back the mode and the code to be set.
 - c. use only the word ROGER.
 - d. use only the word WILCO.

2. The pilot of an aircraft losing two-way communications shall set the SSR transponder to Mode Alpha code:
 - a. 7700
 - b. 7600
 - c. 2000
 - d. 7500

3. When the SSR transponder appears to be unserviceable and repair is not possible before departure, then:
 - a. the aircraft would be permitted to depart to the nearest aerodrome where repair can be carried out.
 - b. the pilot must indicate the failure on the flight plan after which ATC will endeavor to provide for the flight to be continued.
 - c. the flight can only continue in the most direct manner.
 - d. the pilot will not be permitted to commence the flight.

4. What Mode A code shall be used to provide recognition of an aircraft emergency?
 - a. Code 7500
 - b. Code 7600
 - c. Code 7000
 - d. Code 7700

5. Which of the following correctly lists special purpose codes that are used in conjunction with SSR?
 - a. Distress 7700; Unlawful Interference 7600; Communications failure 7500
 - b. Distress 7500; Unlawful Interference 7700; Communications failure 7600
 - c. Distress 7600; Unlawful Interference 7500; Communications failure 7700
 - d. Distress 7700; Unlawful Interference 7500; Communications failure 7600

6. When an aircraft carries a serviceable transponder, the pilot is to operate the transponder:
 - a. only when the aircraft is flying within the airspace where SSR is used for ATC purposes.
 - b. only when the aircraft is flying in CAS.
 - c. only when direct by ATC.
 - d. at all times during flight regardless of whether or not the aircraft is within or outside airspace where SSR is used for ATC purposes.

7. What is the transponder code for radio failure?
 - a. Mode A code 7500
 - b. Mode B code 7600
 - c. Mode A code 7700
 - d. Mode A code 7600

8. Which of the following is not a valid SSR mode A squawk?
 - a. A5555
 - b. A5678
 - c. A2345
 - d. A7777

ANSWERS

Question	Answer	Reference
1.	B	13.3
2.	B	13.5
3.	B	13.7
4.	D	13.5
5.	D	13.5
6.	D	13.2
7.	B	13.5
8.	B	13.3

CHAPTER 14

AIRSPACE

Contents

INTRODUCTION	231
CONTROL AREAS AND ZONES	233
CLASSES OF AIRSPACE	234
REQUIRED NAVIGATION PERFORMANCE (RNP)	236
AIRWAYS AND ATS ROUTES	236
QUESTIONS	238
ANSWERS	244

INTRODUCTION

14.1 Division of Airspace. All the airspace within a state must be contained within one or more Flight Information Regions (FIR). This is the basic unit of airspace within which the most basic form of Air Traffic Control, a Flight Information Service, is available. The alerting service is also available in a FIR. It is usual to give each FIR a name i.e. the London FIR, which geographically identifies the location of the FIR and its associated Area Control Centre (ACC) within which the Flight Information Centre is located. Where a state strictly enforces its sovereignty, the boundaries of that states FIR(s) usually coincide with the national borders of the state. It is not unusual (in Europe, for instance) for FIR boundaries to be 'convenient' (i.e. following Lat/Long or median lines) rather than to follow often convoluted national borders. As well as FIRs, the airspace of a state will be divided into Control Areas (CTAs) and Control Zones (CTRs) and may include restricted, prohibited and danger areas. CTAs can exist in the form of corridors linking other CTAs, these are known as airways. The airspace in the vicinity of an aerodrome is known as an Aerodrome Traffic Zone (ATZ) and is defined in Chapter 6.



Figure 14.1:

14.2 Upper Information Regions (UIRs). Where a state applies a division of airspace vertically, the upper portion of the airspace is defined as an Upper Information Region UIR. Such a division facilitates the application of different rules and separation standards to those of the underlying airspace. The basic assumption is that traffic using the UIR will be essentially in transit en-route, whereas lower traffic will be arriving or departing and therefore manoeuvring. In Europe the division between the FIR and UIR is at FL195 whereas in the USA it is at FL180. The lower boundary of a UIR will always be a VFR FL.

14.3 Open FIR. Airspace within an FIR that is not defined as a CTA, CTR or other 'restricted' airspace is known as the open FIR. Within the open FIR the only air traffic services offered are a Flight Information Service and the Alerting Service.

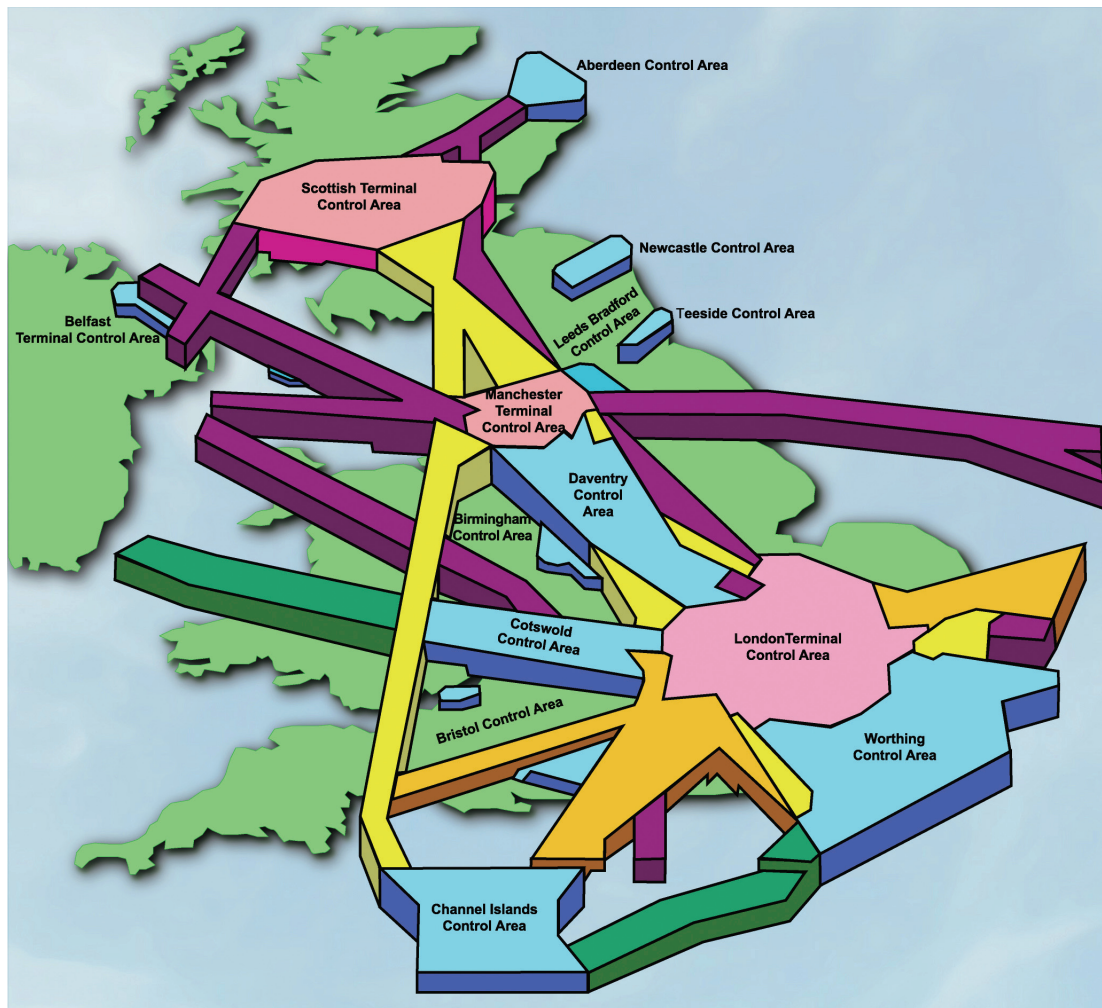

Figure 14.2:

14.4 Oceanic Control Areas (OCAs). Over large areas of the world's Oceans i.e. the North Atlantic, traffic control has special problems (i.e. relatively poor navigation and of necessity HF communications requiring the use of radio operators). To solve the problems, or at least to make them manageable, the airspace above FL55 over the Oceans is designated as OCAs where strict rules are enforced and special navigation procedures are applied.

14.5 Prohibited, Restricted and Danger Areas. All Prohibited, Restricted and Danger Areas within a state are contained in the FIR(s) of that state and subject to notification of activity and change in status by NOTAM (see definition). Each area will be assigned an individual designator consisting of the country identifier, the letter P, R or D followed by a number in the range 001 - 999. For example in the UK a danger off the north coast of Cornwall is designated EG D001. EG is the ICAO identifier for the UK; D means a danger area and 001 is the unique number for that area.

CONTROL AREAS AND ZONES

14.6 CTAs and CTRs. Air Traffic Control is only provided inside what is known as controlled airspace (CAS). It is generally accepted that the upper limit of CAS is defined as FL660. CAS comprises CTAs and CTRs. The primary function of CTAs/CTR is to facilitate ATC to IFR traffic.

14.7 CTAs. A CTA is airspace within which ATC is provided to controlled flights (see definition) which are 'en route' (i.e. not in the departure or approach phases of a flight). The service provided in a CTA is Area Control and is discussed in detail in chapter 17. CTAs are usually established in the vicinity of major aerodromes and at the confluence of airways. As already mentioned, the linking corridors of airspace (airways) are also CTAs. CTAs are defined to exist from a level above ground level (AGL) to an altitude or FL. Where the limit of a CTA is defined as a FL, it will be a VFR FL. The lowest level of a CTA must be at least 200m (700ft) AGL. The airspace within a CTA may be sub-divided to allow different types of operation to exist. The upper portion of a CTA will be predominantly for traffic that is in transit whilst the lower levels will be dedicated to aircraft entering the 'manoeuvring' airspace from above or leaving it. The lower part of the CTA will be used to route aircraft arriving to the individual IAFs for instrument approaches, and to separate departing aircraft from one aerodrome from arriving traffic to another.

14.8 CTRs. CTRs are established in the vicinity of aerodromes to provide ATC to arriving and departing controlled traffic. Within a CTR the ATC service is provided by Approach controllers and is mandatory. A CTR may serve more than one aerodrome. Because a CTR is a zone, the base of any zone is defined as ground level or MSL. Where the upper limit is defined as a FL it would always be a VFR FL. A CTR should be big enough to encompass the airspace required to provide the service and will usually extend at least 5nm from the aerodrome reference position in the direction from which approaches are made. If established within the lateral limits of a CTA, the CTR must extend upwards to the lower limit of the CTA.

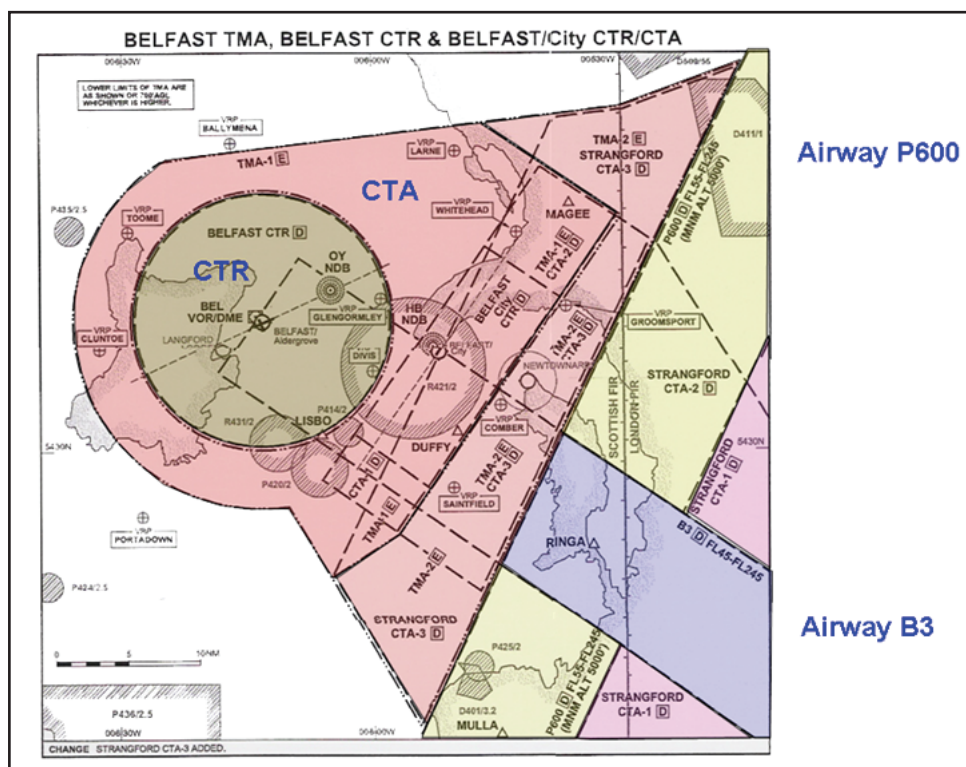

Figure 14.3:

14.9 Upper Control Areas. Where a CTA extends above FL195, the rules applicable may be those pertaining to the lower airspace.

14.10 Control Units. The provision of ATC to flights in CAS is the responsibility of the air traffic control units (ATCUs) within the designated airspace. Area Control Centres provide ATC within CTAs and Approach Control Units provide the service required in CTRs.

CLASSES OF AIRSPACE

14.11 Introduction. In 1980, ICAO introduced a uniform system of classification of airspace to replace the disparate systems of airspace reservations throughout the world. The ICAO system classifies airspace in 7 categories from A to G each class dependant upon the rules applicable, the ATC service provided, separation standards applicable and the utilisation of the airspace.

14.12 Controlled Airspace (CAS). Classes A - E are classified as controlled airspace within which air traffic control is provided to controlled flights. In these classes, IFR flights are always controlled flights. In classes A and B all permitted flights are controlled whereas in classes C and D, ATC is provided to VFR traffic only when conflicting with IFR traffic. CAS is defined as CTAs (including airways) and CTRs. ICAO states that class E airspace cannot be used as a CTR.

14.13 Advisory Airspace. Class F airspace is defined as advisory airspace in which advisory ATC is provided to IFR traffic which requests the service (participating traffic). All IFR traffic flying in class F airspace is required to file a FP but no ATC clearance will be issued. The service is limited to the provision of advice and information and only participating flights are separated. Class F airspace is considered to be temporary established during a trial period whilst it is determined if a full ATC service is applicable.

14.14 SVFR. All classes of airspace which support the establishment of a CTR permit flight under SVFR. SVFR is covered in detail in chapter 6 - Rules of the Air.

14.15 Non-radio. Classes E - G permit VFR traffic to fly without VHF 2-way RTF communications. In areas where the ATC authority consider that the provision of the alerting service is essential (over remote areas or over expansive areas of sea), routes may be established along which (at the appropriate altitude) 2-way RTF communications will be available and traffic will be advised to maintain radio contact with an air traffic services unit.

14.16 Speed Limit. A speed limit of 250 kts IAS is applied to VFR traffic in class C and all traffic in Classes D - G. The limit is applicable to traffic flying below 10,000 ft (FL100) only.

14.17 Flight Information Service (FIS). In Classes C - G, a Flight Information Service is available to aircraft that either request the service, or are otherwise known to ATC. This service provides collision alerts but leaves it to the pilot to take the necessary (as per the rules of the air) avoiding action. Information considered necessary relating to collision avoidance is known as traffic information. In classes A and B airspace, FIS is available but is of a lesser priority to the provision of ATC. Where the provision of traffic information is considered to be of the same priority as ATC, the traffic concerned is known as 'essential traffic,' and the information relating to such traffic is called 'essential traffic information.'

14.18 Airspace Summary. The table on page 237 summarises the requirements and restrictions of the 7 classes of airspace.

CLASSES OF AIRSPACE

Class	Rules	Service	Clearance	Separation	FIS	Speed Limit (NOTE 1)	Radio Watch	CTR SVFR	Use
A	IFR	ATC	YES	ALL		NO	YES	YES	CTA: CTR AIRWAYS: ROUTES
	IFR VFR	ATC	YES	ALL		NO	YES	YES	CTA: CTR AIRWAYS: ROUTES
C	IFR	ATC	YES	IFR-IFR		NO	YES	YES	CTA: CTR (AIRWAYS) (NOTE 5)
	VFR	ATC		IFR-VFR		YES			
		FIS		VFR-IFR	VFR-VFR				
D	IFR	ATC	YES	IFR-IFR	IFR-VFR	YES	YES	YES	CTA: CTR (AIRWAYS) (NOTE 5)
	VFR	FIS		VFR-IFR	VFR-IFR				
				(NOTE 4)	VFR-VFR				
E	IFR	ATC	YES	IFR-IFR	IFR-VFR	YES	YES	NO (NOTE 2)	CTA: (AIRWAYS) (NOTE 5)
	VFR	FIS	NO		VFR-IFR		NO		
F	IFR	ADV ATC	NO	IFR-IFR (NOTE 3)	ALL	YES	YES	NO	ADVISORY ROUTES
	IFR	FIS					YES		
	VFR						NO		
G	IFR	FIS	NO	NONE	ALL	YES	YES	NO	OPEN FIR; FIS ROUTES
	VFR					NO	NO		

Note 1: General Speed Limit is 250 kts IAS enforced below FL100 (10 000ft)

Note 2: Separation as far as is practical

Note 3: Service to participating IFR traffic only (non participating IFR to file FP and maintain 2-way comms)

Note 4: Radar information/advice may be provided to augment FIS in CAS

Note 5: An airway will adopt the classification of the surrounding airspace when it passes through a CTA

Figure 14.4:

REQUIRED NAVIGATION PERFORMANCE (RNP)

14.19 Definition. RNP is a numerical representation of the navigational accuracy required within ATS airspace of a State, and is prescribed on the basis of regional air navigation agreements (RANs). It is based on a 95% containment factor, implying that an aeroplane will be within the required RNP for a period of not less than 95% of the time the aircraft is within the airspace concerned. Alternatively, it can be implied that not less than 95% of the aircraft flying in a given airspace will be navigated within the stated RNP factor. The state is responsible for specifying the RNP value for its airspace.

14.20 Theory. The RNP factor relates to navigational accuracy relating to the aircraft plotted position in nautical miles. For instance, RNP4 implies that the aircraft will be within 4 nm of the plotted position for 95% of the time the aircraft is within the airspace concerned. The applicable RNP factors are: RNP1; RNP4; RNP10; RNP12.6; RNP20. All ATS airspace is classified for RNP. Where VOR/DME is used for airways or RNAV navigation, the RNP specified is RNP5. Within the classification of RNP however, RNP5 does not exist. It was envisaged that VOR/DME would cease to be used for RNAV by the year 2005 and be replaced by more accurate systems offering at least RNP4. This has proved not to be the case and VOR/DME at RNP5 will continue for the foreseeable future. The use of radar permits RNP1 whereas GPS theoretically offers a relative value of RNP0.3. The value of RNP12.6 is derived from the historical accuracy of multiple IRS used for transatlantic navigation.

14.21 Application. A good example of how RNP is used is the track spacing used for the NAT tracks in the MNPSA of the North Atlantic Oceanic regions. The airspace is classified as RNP20 therefore the aircraft flying the routes will be within 20nm of the plotted position for not less than 95% of the flight time. This means that the airspace reserved to a NAT track must be 20nm either side of the specified route. The additional safety 'buffer' will be equal to the RNP so the track spacing will be $20 + 20 + 20 = 60\text{nm}$.

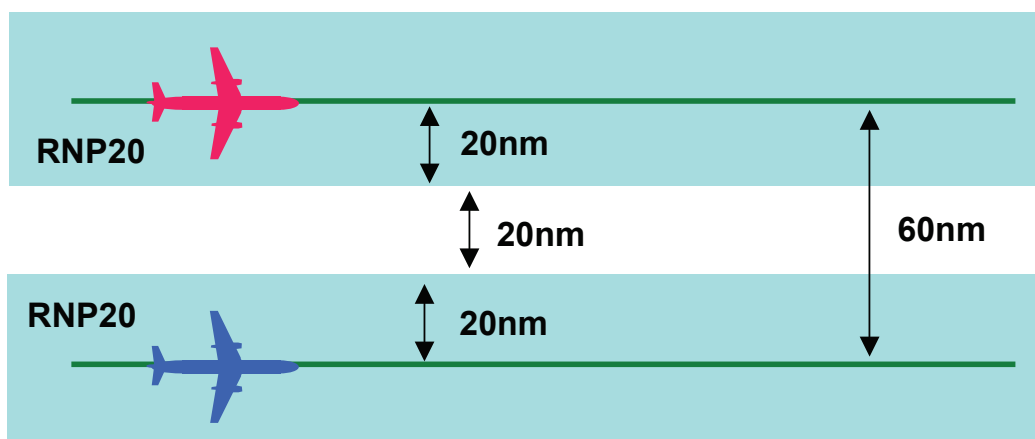

Figure 14.5:

AIRWAYS AND ATS ROUTES

14.22 Establishment. The corridors linking CTAs are called airways. These have evolved by a process of demand as has the road structure in the UK. The airways carry the en-route traffic and are therefore primarily concerned with traffic in the cruise rather than manoeuvring traffic. The ATC problem is relatively simple and involves separating traffic heading in opposite directions, and the allocation of FLs to same direction traffic. Whilst the upper limit of an airway may be defined as the lower limit of the UIR, the lower limit will be dictated by airspace restrictions, terrain avoidance considerations and the needs of other air users (i.e. the military).

Historically, airways served the purpose of linking CTAs with CAS, but in the modern environment of increasing traffic density, airways create as many problems as they solve. They create choke points, reduce flexibility, create delays, increase transit times and reduce fuel efficiency. With the use of smaller aeroplanes and many regional airports the use of airways is declining and a considerable amount of traffic (especially in the UK) now flies off route making use of military radar facilities. Under the 'open skies' policy in Europe and the 'gate-to-gate' operations philosophy encouraged by Eurocontrol, the use of airways will continue to decline effectively making all airspace above about 6000ft CAS.

14.23 Designation. Historically, airways are 'beacon hopping' routes (from VOR to VOR). During the 70s and 80s advances were made in area navigation (RNAV) techniques and RNAV airways using waypoints based on VOR/DME information, were established. Whilst beacon hopping routes (non RNAV routes) still exist, nearly all the airways introduced in the latter part of the 20th century have been RNAV routes. Routes are also classified as being regional (routes which exist between states in one ICAO region) or non-regional (routes which do not extend beyond the borders of a state). The options are therefore:

- Regional non RNAV routes
- Regional RNAV routes
- Non regional non RNAV routes
- Non regional RNAV routes

14.24 Other ATS routes. Other ATS also include SIDs, STARs and low level helicopter routes. All these are given specific designators which can be referred to in ATC communications and in FPs.

14.25 Route Designators. Airways are given a 'designator' which defines the type of airway, gives it a unique number and provides additional information about the type of route. The specific route designator indicates what type of route is defined and the unique number (1 - 999).

A prefix can be added from the following list:

- U = Upper air route
- S = Supersonic transport route
- K = Helicopter low level route

Additionally suffixes may be applied from the list:

- F = Advisory route (Class F airspace)
- G = FIS route (Class G airspace)
- Y = RNP1 route at and above FL200 where turns between 30° and 90° are to be made within the allowable RNP tolerance of a tangential arc defined by a radius of 22.5nm.
- Z = RNP1 route at and below FL190 where turns between 30° and 90° are to be made within the allowable RNP tolerance of a tangential arc defined by a radius of 15nm

QUESTIONS

1. What is the speed restriction in class B airspace under FL100 (10,000 ft) in both VFR and IFR?
 - a. 250 kts IAS.
 - b. 200 kts IAS.
 - c. 260 kts TAS.
 - d. Not applicable.

2. In what class of airspace are all aircraft separated from one another and VFR is permitted?
 - a. D
 - b. E
 - c. A
 - d. B

3. What are the VMC limits for class B airspace?
 - a. Clear of cloud and in sight of the surface.
 - b. 8km flight visibility, 1,000 ft vertically and 1500 m horizontally from cloud.
 - c. 5km flight visibility, 1,000 ft vertically and 1500 m horizontally from cloud.
 - d. The same as class D.

4. A control zone extends laterally from the centre of an aerodrome or aerodromes in the direction of approaching aircraft for at least:
 - a. 7nms.
 - b. 5 nms.
 - c. 15 nms.
 - d. 20 nms.

5. What is the speed limit below 10,000 ft in Class E airspace?
 - a. 250 kts TAS.
 - b. 250 kts IAS.
 - c. Not applicable.
 - d. 200 kts IAS.

6. FIS is provided to aircraft concerning collision hazards in the following classes of airspace:
 - a. C, D, E, F and G.
 - b. F and G only.
 - c. F.
 - d. A, B, C, D,E ,F and G.

7. For VFR flight in class E airspace:
 - a. ATC clearance and two way radio are required.
 - b. two-way radio not required.
 - c. ATC clearance and/or two way radio are required.
 - d. ATC clearance is required.

8. Danger, Prohibited and Restricted areas must be designated by:
- country identifier, followed by P/D/R, followed by the identifier.
 - country identifier followed by P/D/R.
 - P/D/R followed by the identifier.
 - country identifier followed by numbers.
9. In which class or classes of airspace would VFR traffic be separated from other VFR traffic?
- B
 - B; C; D; E
 - B; C
 - B; C; D
10. What is the primary function of a CTR and a CTA?
- The controlling of all traffic close to an aerodrome.
 - The controlling of all traffic in Class F airspace.
 - The controlling of all traffic in Class F & G airspace.
 - The controlling of IFR traffic.
11. What is the speed limit for VFR traffic in class C airspace below 10,000 ft:
- not applicable.
 - 250 kts TAS.
 - 250 kts IAS.
 - 270 kts IAS.
12. What type of airspace extends from the surface to a specified upper limit?
- Control area.
 - Air Traffic Zone.
 - Control zone.
 - TMA.
13. What class of airspace can you get an advisory service for IFR traffic and a FIS for VFR traffic?
- C
 - D
 - C
 - F
14. The lowest height of the base of a CTA above ground or water is:
- 300m.
 - 150m.
 - 200m.
 - 500m.
15. In which class or classes of airspace is IFR separated from IFR and all other traffic gets FIS?
- A
 - B
 - D
 - D and E.

16. The lower boundary of an UIR must be:
- an IFR flight level.
 - a VFR flight level.
 - is not specified.
 - at any flight level.
17. What is the upper limit of a CTA?
- 2,000 ft.
 - 3,000 ft.
 - 5,000 ft.
 - A VFR Flight Level.
18. What is the maximum speed permitted in class B airspace?
- Not applicable.
 - 260 kts IAS.
 - 250 kts IAS.
 - 250 kts only below FL100 (10,000ft).
19. What class of airspace permits both IFR and VFR, and IFR participating traffic receives advisory ATC for separation?
- F
 - E
 - G
 - D
20. In which airspace(s) can you fly VFR without a radio?
- E & G.
 - D.
 - E, D.
 - C, D, E.
21. In which class of airspace is IFR and VFR permitted; IFR is separated from all traffic, VFR separated from IFR and VFR receives traffic information about other VFR traffic?
- A
 - B
 - C
 - D
22. In class C airspace, what flights are separated?
- All flights.
 - IFR from all flights; VFR from VFR.
 - IFR from IFR; VFR from IFR and VFR from VFR.
 - IFR from IFR; IFR from VFR; VFR from IFR.

23. What service is provided to IFR/VFR traffic in class E airspace?
- ATC to IFR and VFR.
 - ATC to IFR; FIS to VFR.
 - ATC to IFR and radio equipped VFR; FIS to non radio VFR.
 - ATC to IFR; Advisory ATC to IFR in VMC; FIS to VFR.
24. A Control Zone has to exist to at least:
- 5 nms from the centre of the airfield or airfields concerned in the direction from where approaches can be made.
 - 20 nms from the centre of the airfield or airfields concerned in the direction from where approaches can be made.
 - 15 nms from the centre of the airfield or airfields concerned in the direction from where approaches can be made.
 - 10 nms from the centre of the airfield or airfields concerned in the direction from where approaches can be made.
25. Whenever flying below 3,050m (10,000 ft) AMSL in Class C Airspace the speed restriction for IFR is:
- 240 kts IAS.
 - 250 kts TAS.
 - not applicable.
 - 250 kts IAS.
26. Airspace, in which IFR and VFR flights are permitted and in which IFR flights are separated from other IFR flights and receive traffic information concerning VFR flights, and VFR flights receive traffic information concerning all other flights, is classified as:
- C
 - B
 - A
 - D
27. What is the speed limit (IAS) in airspace E?
- 250 kts for IFR and VFR, below FL 100.
 - 250 kts for IFR only, below FL 195.
 - 250 kts for IFR and VFR, at all altitudes.
 - 250 kts for IFR only, below FL 100.
28. Controlled airspace, in which IFR and VFR flights are allowed and where all flights are separated from each other by ATC, is classified as:
- A
 - D
 - B
 - E

29. Flight information service provided to flights shall include the provision of information concerning collision hazards to aircraft operating in airspace classes:
- A to G (inclusive).
 - C to G (inclusive).
 - F and G.
 - A to E (inclusive).
30. Which of the following is true concerning the rules and regulations in the UIR compared with the airspace below?
- The same rules apply if the airspace is of the same class.
 - They are agreed by the Air Navigation Meeting.
 - They are identical to the airspace below.
 - They do not have to be the same as those in the airspace below.
31. A Flight Information Service shall be provided to all aircraft which are likely to be affected by the information which are:
- provided with ATC or otherwise known to the relevant ATS unit.
 - provided with Air Traffic Control only.
 - known to the relevant ATS units only.
 - known to the relevant ATS unit or have filed a flight plan.
32. Who is responsible for designating the RNP for an airway?
- The State.
 - The State + ICAO.
 - ICAO.
 - ATC.
33. RNP4 is a containment value meaning that a percentage of aircraft operating along a particular route would be within 4nm of the centre line all the time. What is that percentage?
- 98%.
 - 93%.
 - 95%.
 - 90%.
34. RNP (Required Navigation Performance) is prescribed:
- by states but not on the basis of Regional Air Navigation agreements (RANs).
 - by ICAO on the basis of RANs and applied by the state.
 - by RANs.
 - by states based on RANs.
35. A RNP1 route designated with suffix Z indicates that for the route at or below FL190 and all turns shall be made within the allowable RNP tolerance of a tangential arc between the straight leg segments with a radius of:
- 10nm for turns between 30° and 90°.
 - 15nm for turns between 30° and 90°.
 - 22.5nm for turns between 30° and 90°.
 - 30nm for turns between 30° and 90°.

36. A RNP1 route designated with suffix Y indicates that for the route at or above FL200 and all turns shall be made within the allowable RNP tolerance of a tangential arc between the straight leg segments with a radius of:
- a. 10nm for turns between 30° and 90°.
 - b. 15nm for turns between 30° and 90°.
 - c. 22.5nm for turns between 30° and 90°.
 - d. 30nm for turns between 30° and 90°.
37. Who is responsible for designating the RNP for an airway?
- a. The State.
 - b. The State and ICAO.
 - c. ICAO.
 - d. RAN.
38. Who organises the RNP specification for airspace?
- a. The State in which the airspace is located.
 - b. ICAO.
 - c. The State + ICAO.
 - d. States who agree what the RNP should be.

ANSWERS

Question	Answer	Reference
1.	D	14.16
2.	D	14.18
3.	D	6.5
4.	B	14.18
5.	B	14.16
6.	A	14.17
7.	B	14.18
8.	A	14.18
9.	A	14.18
10.	D	14.6
11.	C	14.16
12.	C	14.8
13.	D	14.13/14.18
14.	B	14.7
15.	D	14.18
16.	B	14.2
17.	D	14.7
18.	A	14.16
19.	A	14.13
20.	A	14.15
21.	C	14.18
22.	D	14.18
23.	B	14.18
24.	A	14.8
25.	C	14.16
26.	D	14.18
27.	A	14.16
28.	C	14.18
29.	B	14.17
30.	D	14.2
31.	A	14.17
32.	A	14.19
33.	C	14.19
34.	D	14.19
35.	B	14.25
36.	C	14.25
37.	A	14.19
38.	A	14.19

CHAPTER 15

AIR TRAFFIC SERVICES

Contents

INTRODUCTION	247
AIR TRAFFIC CONTROL	248
ATC CLEARANCES	248
CONTROL OF PERSONS AND VEHICLES AT AERODROMES.	250
THE FLIGHT INFORMATION SERVICE	251
THE ALERTING SERVICE	253
PROCEDURES	254
QUESTIONS	256
ANSWERS	262

INTRODUCTION

15.1 The Air Traffic Services (ATS). Annex 11 to the Chicago Convention lays down the SARPs for the establishment of an Air Traffic Control services in each of the contracting states. Each state is required to establish an authoritative body responsible for setting up and regulating the operation of the ATS of the state. In the UK the body responsible is the UK CAA and the operating organisation is National Air Traffic Services (NATS).

15.2 Document 4444. Because the SARPs of Annex 11 are (by necessity) insufficiently detailed, PANS ATM (Air Traffic Management) (Document 4444) is published by ICAO as the definitive reference for the establishment and management of an ATS. PANS ATM is mainly directed to ATS personnel; however, flight crews should be familiar the content of the sections relating to ATM; ATS and separation; ADS and CPDLC; ATIRs and RPL.

15.3 Objectives. The objectives of an ATS are to:

- Prevent collisions between aircraft;
- Prevent collisions between aircraft on the manoeuvring area and obstructions thereon;
- Expedite and maintain an orderly flow of air traffic;
- Provide advice and information useful for the safe and efficient conduct of flights;
- Notify appropriate organisations regarding aircraft in need of SAR aid, and assist such organisations as required.

15.4 ATS Divisions. ATS comprises three divisions:

- Air Traffic Control Service;
- Flight Information Service
- Alerting Service

15.5 ATC Service. The ATC Service is divided into three sub-divisions:

- **Area Control Service.** The provision of ATC for controlled flights within CTAs and en-route in FIRs and UIRs.
- **Approach Control Service.** The provision of ATC for controlled flights associated with arrival and departure. Usually provided within CTRs.
- **Aerodrome Control Service.** The provision of ATC to aerodrome traffic at controlled aerodromes.

15.6 The Need for ATS. An ATS is set up in consideration of the following:

- The types of traffic involved
- The density of traffic
- The meteorological conditions
- Other relevant factors (i.e. mountainous terrain, extensive sea areas; limited navigational facilities etc...)

15.7 ACAS. The carriage of ACAS by aircraft in a given area will not be taken into consideration when determining the level of service required to be established.

AIR TRAFFIC CONTROL

15.8 Applicability. Air Traffic Control (ATC) is the service provided to controlled flights inside controlled airspace or to aerodrome traffic at controlled aerodromes. ATC is always provided to IFR traffic inside CAS whereas ATC is only provided to VFR flights in classes B, C and D. Additionally, all SVFR flights are provided with ATC.

15.9 ATS Units. ATS units comprise Air Traffic Control Units (ATCUs) and Flight Information Centres (FICs). The ATS unit providing ATC are ATCUs and those providing flight information are FICs. The ATCU providing area control (ATC to en-route traffic) is known as an Area Control Centre (ACC). It is usual to prefix the unit with a geographical name i.e. London ACC. Within a CTR the unit providing approach control is the approach control office usually located in a control tower at an aerodrome. Combined approach control offices exist where approach control for multiple aerodromes/CTRs is provided i.e. London Terminal Control Centre (LTCC) which provides approach control for Heathrow, Gatwick, Stansted, Luton, London City, Biggin Hill and Northolt. Aerodrome Control is provided by an aerodrome control tower. Within a FIR, the provision of FIS and the Alerting service may be from the same ATSU.

15.10 Ground Control. The ground movement of aircraft and vehicles is the responsibility of the aerodrome controller. However, the provision of services to aircraft moving on the manoeuvring area of an aerodrome and on the apron may be delegated to a ground movements controller usually to limit the aerodrome RTF to flight safety messages concerning the take-off and landing of aircraft. At major aerodromes, the movement of aeroplanes and vehicular traffic on the apron may be delegated to an Apron Management Service. In this case, ATC would commence once the aircraft moves onto the taxi-way and will cease when the pilot takes instructions from a marshaller.

15.11 Time in ATC. ATC units throughout the world are required to report time in hours, minutes and seconds with time referenced to co-ordinated universal time (UTC). This uses the 24 hour clock. UTC has been previously known as 'Zulu' time or Greenwich Mean Time. 1200UTC would be the time at which the sun is directly overhead the Greenwich meridian (0°E/W). The use of one standard time reference (rather than local time) makes the handling of flight plans simple and facilitates co-ordination of ATC clearances.

15.12 Time Accuracy. ATSU clocks and timing devices are to be checked to ensure that the times indicated is within +/- 30 seconds of UTC at all times. Time checks round up or down to the nearest minute.

ATC CLEARANCES

15.13 Definition. An ATC clearance is authorisation for an aircraft to proceed under conditions specified by an ATCU.

15.14 Purpose. Clearances are issued solely for expediting and separating air traffic and are based on known traffic conditions. This includes traffic moving on the ground at an airport as well as airborne traffic. If a clearance given to a pilot is unsuitable (or impossible to comply with), an alternative clearance may be requested. If possible, such a clearance will be offered but the pilot must understand that alternative clearances may result in delays being incurred. A clearance must be issued early enough so that there is sufficient time for the clearance to be complied with.

15.15 Basic Responsibility. When flying in accordance with an ATC clearance, the pilot is not relieved of the basic responsibility for ensuring the safety of the aircraft, including terrain avoidance, and that of other air users. Likewise, the Rules of the Air apply to any flight proceeding in accordance with an ATC clearance. When an aircraft is under radar vectoring, the radar controller will issue clearances such that the required obstacle clearance will exist at all times.

15.16 Application. The practical application of ATC clearances is to provide a method whereby ATC gives instructions to aircraft to facilitate separation. In general, within CAS, IFR flights are always separated from other IFR flights. In classes B and C, IFR is separated from VFR and in class B, VFR is separated from other VFR. Within a CTR it is normal practice to separate SVFR flights.

15.17 Contents of a Clearance. Clearances are to contain positive and concise data and shall be phrased in a standard manner. An ATC clearance should include:

- The aircraft identification as shown on the FP;
- Any clearance limitation;
- The route of the flight;
- Level allocated for the flight (or for the initial/current part of the flight);
- Any other necessary instructions or information, such as SIDs, STARs, communications or clearance expiry time;
- Transition level in approach clearances if so prescribed or when requested by the pilot;
- QNH (except when it is known that the aircraft has already received the information): when first cleared to an altitude below the transition level; in approach clearances; in clearances to enter the traffic circuit; in taxi clearances for departing aircraft.

In order to expedite the delivery and reading back of clearances, standard phraseology may be used such as "*cleared via flight planned route to ...*" or "*cleared via Midhurst departure 2G*" or "*cleared via Ockham 1D arrival*". In such cases the pilot will be required to refer to the reference document or procedure plate.

15.18 Clearance Co-ordination. The responsibility for issuing a route clearance for a flight rests with the ACC of the FIR in which the flight originates. Ideally, before issuing a clearance, an ATCU would co-ordinate (agree) a clearance with all the other ACCs en-route. In practice this not feasible especially for long intercontinental flights. In this case, the ACC would issue a clearance limited to the initial FIR or where the flight time in the originating FIR is short (i.e. flights originating from Heathrow entering the Paris FIR), it would be essential to co-ordinate with at least the next FIR to be entered. Where it has not been possible to co-ordinate the clearance for the entire route, the aeroplane would be given clearances on a rolling (downstream) basis from FIR to FIR. Under certain circumstance it may not be possible for the current ACC to obtain a downstream clearance from the subsequent FIR in which case, the aircraft may be requested to originate communications with the downstream FIR and obtain a clearance prior to entering the airspace of that FIR.

15.19 Clearance Read-back. Flight crews are required to 'read back' to the air traffic controller, safety related parts of ATC clearances and instructions which are communicated by voice. The following items must always be read back:

- ATC route clearances
- Clearance relating to the use of runways (i.e. land, take-off, cross, enter and back-track, hold short of)
- Runway in use; altimeter settings; SSR codes; level instructions; heading and speed instructions; transition levels

15.20 Air Traffic Flow Management (ATFM). Using modern data processing systems and prior flight planning, especially using repetitive flight plans (RPLs), it is now possible to predict traffic loading in each sector of the route structure of the airspace within a FIR. Where this exceeds that which can normally be accommodated, the ATFM unit in the ACC will advise flight crews and operators that delays are likely or that restrictions may be applied. Such information is disseminated generally so that operators can see that any disruption is incurred equitably. In practice, predictable delays are handled by delaying the take-off of an aeroplane such that the delay is absorbed on the ground rather than in the terminal phase of a flight. Clearly, this has economic, environmental and safety advantages and is the most obvious practical advantage of ATFM.

CONTROL OF PERSONS AND VEHICLES AT AERODROMES

15.21 Rules of the Air. The movement of persons or vehicles including towed aircraft on the manoeuvring area of an aerodrome is to be controlled by the aerodrome control tower as necessary to avoid hazards to them or to aircraft landing, taxiing or taking off.

15.22 Low Visibility Procedures. When Low Visibility Operations are in force (ground visibility below 800m) persons and vehicles operating on the manoeuvring area will be kept to a minimum. Special procedures will be implemented to safeguard the ILS/MLS sensitive areas when CAT II and CAT III precision instrument operations are in progress (ground visibility less than 550m).

15.23 Emergency Vehicles. Emergency vehicles proceeding to the scene of an accident or incident will have priority over all other surface movement traffic.

15.24 Vehicles on the Manoeuvring Area. The following rules cover the movement of vehicles on the manoeuvring area of an aerodrome:

- Vehicles and vehicles towing aircraft are to give way to aircraft that are landing, taxiing or taking off.
- Vehicles are to give way to vehicles towing aircraft.
- Vehicles will give way to other vehicles in accordance with ATS unit instructions.
- Notwithstanding a, b, and c above, vehicles and vehicles towing aircraft are to comply with instructions issued by the aerodrome control tower.

THE FLIGHT INFORMATION SERVICE

15.25 Introduction. As already stated, the basic unit of airspace within a state is the Flight Information Region (FIR). In theory, a FIR can exist without CAS, in which case the only services provided to air traffic would be a flight information service (FIS) and the alerting service. Even where ATC is provided inside CAS, FIS will be provided although at a lower priority to ATC. The provision of any service relies on a regular flow of information and the provision of FIS relies heavily on the Aeronautical Information Service (AIS) established by each state in accordance with Annex 15. AIS is covered in Chapter 18 of these notes.

15.26 FISOs. Outside of CAS and at uncontrolled aerodromes, flight information is provided by Flight Information Service Officers (FISOs) operating from a Flight Information Centre (FIC). Where a FIS is provided the name of the office providing the service will be suffixed 'information.' FISOs are licensed to provide the service but are not permitted to offer any service that can be described as ATC. The only exception to this is the provision of ATC to aircraft taxiing on the ground at a controlled aerodrome but this is strictly limited to movements prior to entering the runway for take off. The FIS provided in the London FIR is by 'London Information' in three geographic sectors on dedicated VHF frequencies.

15.27 Operation. Flight Information is provided to all air traffic that is likely to be affected by the information. Specifically:

- Aircraft which are provided with an ATC service;
- Aircraft which are otherwise known to the relevant ATS units.

The information provided by the FIS is to include:

- SIGMET and AIRMET (see definition below);
- Volcanic eruption activity;
- Release of radioactive or toxic material into the atmosphere;
- Information concerning change of serviceability of radio navigation aids;
- Information concerning change of conditions concerning aerodromes;
- Information concerning unmanned free balloons;
- Other information considered pertinent to safety.

Additionally, information is to be provided concerning:

- Weather conditions reported or forecast at departure; destination or alternate aerodromes;
- Collision hazards to aircraft operating in classes C; D; E; F and G airspace;
- For flights over sea areas (when requested by pilots), details of surface vessels.

Apart from the delivery of FIS on discrete VHF frequencies, the majority of 'routine' FIS is broadcast by the Operational Flight Information Service (OFIS).

15.28 AIRMET. According to Annex 11, AIRMET is defined as:

'Information concerning the occurrence or expected occurrence of specified en-route weather phenomena which may affect the safety of low-level aircraft operations and which was not already included in the forecast issued for low-level flights in the FIR concerned or sub-area thereof.'

15.29 OFIS. OFIS is broadcast in three specific areas:

- HF OFIS
- VHF OFIS
- ATIS

Both HF OFIS and VHF OFIS broadcast VOLMET (METAR, SIGMET and TAF) information for specific aerodromes (or groups of aerodromes) in accordance with a schedule. The table below shows the VHF OFIS Volmet coverage in the London, Scottish and Shannon FIRs.

Location	Frequency	Airports covered
London Main	135.375	Amsterdam, Brussels, Dublin, Glasgow, London LGW, London LHR, London STN, Manchester, Paris CDG
London North	126.6	Blackpool, East Midlands, Leeds Bradford, Liverpool, London LGW, Manchester, Newcastle, Isle of Man, Teeside
London South	128.6	Birmingham, Bournemouth, Bristol, Cardiff, Jersey, Luton, Norwich, Southampton, Southend
Scottish	125.725	Aberdeen, Belfast BFS, Edinburgh, Glasgow, Inverness, London LHR, Prestwick, Stornoway, Sumburgh
Dublin	127.0	Dublin, Shannon, Cork, Belfast BFS, Glasgow, Prestwick, Manchester, London LHR, London LGW

Figure 15.1: Volmet broadcasts.

HF OFIS Volmet is broadcast by the Oceanic Control Centres (i.e. Shanwick) and covers the aerodromes used by transiting traffic.

15.30 ATIS. Automatic Terminal Information Service broadcasts (ATIS) consists of two types of broadcast: Voice ATIS and Data ATIS. The preparation and dissemination of ATIS is the responsibility of ATS.

15.31 Voice - ATIS. This is provided at aerodromes where there is a requirement to reduced voice channel communications. ATIS broadcasts comprise:

- One broadcast serving arriving aircraft; or
- One broadcast serving departing aircraft; or
- One broadcast serving both arriving and departing aircraft, or
- Two broadcasts serving arriving or departing aircraft where one broadcast would be exceptionally long.

15.32 Transmission. Voice ATIS is usually transmitted on a discrete VHF frequency (displayed on all aerodrome plates). It may be transmitted on the voice channel of a relevant VOR (i.e. departure ATIS on the VOR used as the primary VOR for a SID; or arrival ATIS on the VOR that serves as the IAF for a procedure). ATIS is never transmitted on the voice channel of ILS. Voice ATIS is continuous and repetitive.

15.33 ATIS Information. ATIS information normally relates to a single aerodrome and the broadcast should not last longer than 30 seconds. It is updated immediately any significant change occurs. ATS is responsible for making sure that the service is available and up to date. Each sequence of ATIS broadcasts will have a specific sequential broadcast designator letter. On initial contact with ATC, aircraft are to acknowledge receipt of the relevant ATIS with reference to the current information designator.

“Oxford Tower G-ABCD bay 27, information Charlie, QNH 1003 request start”

15.34 Cloud Information. The ATIS broadcast will only include cloud cover when the cloud base is below 5000ft or the highest MSA (whichever is higher), or when cumulonimbus cloud is present.

THE ALERTING SERVICE

15.35 Introduction. Within an FIR, the provision of service to aircraft requesting assistance or indicating that they may require assistance is the responsibility of the Alerting Service of ATS. This service is provided by any ATS unit (ACC, ATCU, FIC etc...) regardless of the type of service normally offered. The Alerting Service is the link between the aircraft needing assistance, and the services that can provide that assistance. Where necessary, the provision of a service to aircraft in need of assistance will have priority over all other air traffic services.

15.36 Application. The Alerting Service is provided to:

- All aircraft provided with ATC;
- As far as practicable, all aircraft that have filed a FP or are otherwise known to ATC, and
- Any aircraft known (or believed to be) the subject of unlawful interference.

FICs and ACCs will serve as the central point for collecting all information relevant to an aircraft state of emergency, and forwarding such information to the appropriate rescue co-ordination centre (RCC). If an emergency arises when an aircraft is under the control of the aerodrome or approach controller, that office will notify the ACC or FIC which in turn will notify the RCC. If the urgency of the situation dictates, the aerodrome or approach office will set in motion all necessary local emergency organisations that can give immediate assistance.

15.37 Communication of Information. Where it is established by an ATS unit that an aircraft is in a state of emergency in the vicinity of other aircraft, the ATS unit will inform the other aircraft of the nature of the emergency as soon as possible. If an aircraft is being subjected to unlawful interference, no reference will be made in ATC communications unless it has been referred to in communications from the aircraft in the first place, and such communication will not make the situation worse.

15.38 Stages of Emergency. There are three stages of alert (known generically as the emergency phase), these are:

- **Uncertainty phase (code word: INCEFA):** This stage exists when no communication has been received from an aircraft within a period of 30 minutes after a time at which normal communication should have been made, or the aircraft fails to arrive at the destination within 30 minutes of the estimated arrival time.

- **Alert phase (codeword: ALERFA).** The alert phase would be declared following the uncertainty phase (except when evidence exists that would allay apprehension as to the safety of the aircraft or its occupants) when:
 - Subsequent attempts to make communication have failed and there is not further news of the aircraft; or
 - The aircraft fails to land within 5 minutes after the issuing of a landing clearance; or
 - Information has been received that the operating efficiency of the aircraft is impaired (but not that a forced landing is likely); or
 - It is known that an aircraft has been subject to unlawful interference.

- **Distress phase (codeword DETRESFA).** The distress phase would be declared following the alert phase (except where there is reasonable certainty that the aircraft and its occupants are not threatened by grave and imminent danger):
 - Further attempts at communication are unsuccessful and widespread enquiries indicate the probability that the aircraft is in distress; or
 - The fuel on board is considered to be exhausted; or
 - Information is received that the operating efficiency of the aircraft is impaired to the extent that forced landing is likely; or
 - Information is received that the aircraft is about to or has made a forced landing.

PROCEDURES

15.39 Speed Control. The speed of an aircraft may be prescribed by ATC as a means of maintaining separation. The use of the Mach No technique (in the arrangement of longitudinal separation will be discussed in Chapter 16). Where speed control is applied, adequate notice is to be given to flight crews to ensure compliance. Prolonged use of speed control is not recommended as this can affect fuel usage. When applied, changes in speed should be limited to those necessary to maintain separation minima or spacing. At or above FL250 speed adjustments should be in multiples of M0.01 and below FL250 in multiples of 10kts IAS. On intermediate and final approach, speed changes are to be limited to minor adjustments of 20 kts IAS. Speed control is not to be applied to aircraft after passing a point 4 nm from the threshold of the landing runway.

15.40 Automatic Dependent Surveillance (ADS). Automatic Dependent Surveillance-Broadcast (also called ADS-B) is a system by which aeroplanes constantly broadcast their current position and altitude, category of aircraft, airspeed, identification, and whether the aircraft is turning, climbing or descending, over a dedicated radio data link. The ADS system was developed in the 1990s. It relies on data from the Global Positioning System, or any navigation system that provides an equivalent or better service. The maximum range of the system is line-of-sight, typically less than 200 nautical miles (370 km). The ADS transmissions are received by the Air Traffic Service unit serving the airspace in which the aircraft is operating, and all other ADS equipped aircraft within reception range. Basic ADS consists of:

- Latitude
- Longitude
- Altitude
- Time
- Figure of Merit (accuracy)

15.41 AIREP. Where required operational and meteorological information can be transmitted in the form of an air-report (AIREP). AIREPs consist of routine and special reports. A routine report has three sections:

- Section 1 - Position report
- Section 2 - Operational information (ETA and endurance)
- Section 3 - Meteorological information

Section 1 is mandatory and section 2 is transmitted when requested by the operator or considered necessary by the pilot. Section 3 is transmitted when the aircraft has been requested to make routine met reports at specific en route points.

15.42 AIREP SPECIAL. Special air-reports (AIREP SPECIAL) are reported by all aircraft which encounter any of the following hazards:

- Severe turbulence;
- Severe icing;
- Severe mountain wave;
- Thunderstorms without hail that are obscured, embedded, widespread or in line-squalls;
- Heavy dust or sand storms;
- Volcanic ash cloud.

15.43 Air Traffic Incident Reports (ATIR). In order to provide a medium for reporting, investigation and feedback of incidents occurring whilst an aircraft is under ATC, a system of ATIRs has been established. The ATIRs relate to:

- Aircraft proximity reports (AIRPROX)
- ATC procedure reports
- ATC equipment reports

AIRPROX reports may be originated by either the pilot, AIRPROX(P), or by a controller, AIRPROX(C). From a pilot, the initial report is filed by RTF and the report completed on the ground.

QUESTIONS

1. What is the definition of Distress?
 - a. An emergency condition where an aircraft is in grave and imminent danger and requires immediate assistance.
 - b. Persons on board an aircraft are in imminent danger and the flight cannot be continued.
 - c. The aircraft will be unable to land at a suitable aerodrome.
 - d. The aeroplane has a message to transmit concerning the safety of person on board or within sight.
 2. What defines the alert phase (ALERFA)?
 - a. A situation in which an aeroplane and passengers are known to be in serious and imminent danger.
 - b. A situation where it is certain that fuel is exhausted.
 - c. A situation where apprehension exists about an aeroplane and its safety.
 - d. A situation in which an aeroplane and its passengers are in emergency.
 3. Voice ATIS is transmitted on a:
 - a. discrete VHF frequency only.
 - b. discrete VHF frequency or on voice on VOR.
 - c. VHF frequency or on ILS frequency.
 - d. ILS only.
 4. Who is responsible for initiating the Alert Phase?
 - a. FIC or the relevant ATCU.
 - b. The State and ATC.
 - c. The Area Control and the RCC.
 - d. RCC and the FIR.
 5. What is the definition of the Emergency Phase?
 - a. The Distress Phase.
 - b. The Alarm Phase.
 - c. The Alert Phase.
 - d. A generic term meaning as the case maybe the Uncertainty Phase, the Alert Phase or the Distress Phase.
 6. FIS is provided to aircraft concerning collision hazards in the following classes of airspace:
 - a. C, D, E, F, G.
 - b. F and G only.
 - c. F.
 - d. A, B, C, D, E, F, G.
 7. What are the three elements of an Air Traffic Control Service?
 - a. Radar, SAR and FIS.
 - b. Area, Approach and Aerodrome.
 - c. Radar, Procedural and FIS.
 - d. Radar, Procedural and Alerting Service.
-

8. What does an ATSU consist of?
 - a. An ACC and FIC.
 - b. An ATCU and FIC.
 - c. A combined radar unit and ATC tower.
 - d. An ACC and Approach Control.

 9. How often is an ATIS updated?
 - a. Every 30 minutes for VFR, every 60 minutes for IFR.
 - b. When there is a change in information, irrespective of content or intensity.
 - c. When the minimum ceiling and visibility are below VFR minimum.
 - d. When there is a significant change in information.

 10. Which of the following statements concerning the alerting service is correct?
 - a. The alert phase is initiated when an aircraft fails to communicate within 30 minutes.
 - b. FIS and the alerting service may be provided by the same ATCU.
 - c. The distress phase is always initiated for aircraft subject to unlawful interference.
 - d. All other traffic in the vicinity of an aircraft subjected to unlawful interference is to be notified.

 11. An aircraft has been cleared to land and fails to do so within 5 minutes of the ETA of landing and communications have not been re-established with the aircraft. What phase of the Alerting Service will be declared by the ATSU?
 - a. DETRESFA.
 - b. INCERFA.
 - c. ALERFA.
 - d. EMERGFA.

 12. When an aircraft encounters difficulty, the initiation of the alert phase is the responsibility of:
 - a. Air Traffic Coordination Centres.
 - b. Air Traffic Control Units and Flight Information Centres.
 - c. Search and Rescue Coordination Centres.
 - d. Air Traffic Control Centres only.

 13. According to ICAO Annex 11, what does the following statement define: "Information concerning the occurrence or expected occurrence of specified en-route weather phenomena which may affect the safety of low-level aircraft operations and which was not already included in the forecast issued for low-level flights in the FIR concerned or sub-area thereof."
 - a. NOTAM.
 - b. SIGMET Information.
 - c. AIRMET Information.
 - d. En-route Weather Report.

 14. A Flight Information Service shall be provided to all aircraft which are likely to be affected by the information and which are:
 - a. provided with ATC and which are otherwise known to the relevant ATS unit.
 - b. provided with ATC.
 - c. known to the relevant ATS unit.
 - d. known to the relevant ATS unit and which have filed a FP.
-

15. Aircraft "A" with ATC clearance is flying in VMC in a CTR. Aircraft "B" without ATC clearance is converging at approximately the same altitude. Which aircraft has the right of way?
- Aircraft "A" if "B" is on its right.
 - Aircraft "A" regardless of the position of "B".
 - Aircraft "B" regardless of the position of "A".
 - Aircraft "B" if "A" is on its left.
16. Air Traffic Control Centres issue clearances for the purpose of:
- providing advisory ATC.
 - expediting and separating traffic.
 - achieving separation between IFR flights.
 - providing FIS.
17. ATSU clocks and other time recording devices shall be checked as necessary to ensure correct time to within UTC plus or minus:
- 10 seconds.
 - 1 minute.
 - 30 seconds.
 - 15 seconds.
18. The Alerting Service is to be provided for:
- all aircraft having filed a FP or otherwise known to ATC, as far as is practicable.
 - for all controlled flights; to any aircraft known or believed to be the subject of unlawful interference; and all aircraft having filed a FP or otherwise known to ATC, as far as is practicable.
 - only to aircraft provided with ATC.
 - only to aircraft known or believed to be the subject of unlawful interference.
19. The Approach Control Service is an ATC service:
- provided for arriving and departing controlled flights.
 - provided for arriving and departing IFR flights.
 - provided for IFR and VFR flights within a CTR.
 - provided for IFR flights within an ATZ.
20. A Flight Information Region (FIR) is airspace within which the following services are provided:
- Flight Information Service; Alerting Service; Advisory Service.
 - Flight Information Service only.
 - Flight Information Service and Advisory Service.
 - Flight Information Service and Alerting Service.
21. An AIREP comprises a number of sections. What is the content of part 1?
- Noted weather.
 - Flight identification and noted weather.
 - Urgent messages.
 - A position report.

22. Clearances will be issued by ATC for the purpose of:
- providing alerting services.
 - achieving separation between air traffic.
 - providing a flight information service.
 - providing advisory ATC.
23. Air Traffic Service Unit (ATSU) means:
- ATCUs and Air Services reporting units.
 - FICs and Air Services reporting units.
 - ATCUs; FICs and Air Services reporting units.
 - ATCUs and FICs.
24. What is the content of section 2 of an AIREP?
- ETA and endurance.
 - EET and endurance.
 - Present position and ETA.
 - ETA for the FIR boundary and endurance.
25. The Air Traffic service is provided for the purpose of:
- preventing collisions between aircraft, between aircraft and obstacles on the manoeuvring area and expediting and maintaining an orderly flow of air traffic.
 - applying separation between aircraft and expediting and maintaining an orderly flow of air traffic.
 - preventing collisions between controlled aircraft and expediting and maintaining an orderly flow of air traffic.
 - avoiding collisions between all aircraft and expediting and maintaining an orderly flow of air traffic.
26. The Alerting Service is provided by:
- the ATS unit responsible for the aircraft at that moment.
 - the ATS unit responsible for the aircraft at that moment when it can transmit on 121.5Mhz.
 - only ATC units.
 - Area Control Centres.
27. When is ATIS updated?
- Only when the weather conditions change enough to require a change in the active runway or instrument approach in use.
 - Only when the ceiling and/or visibility changes by a reportable value.
 - Upon the receipt of any significant change.
 - Every 30 minutes if weather conditions are below those for VFR, otherwise hourly.
28. Who is responsible for an ATC clearance to be safe in respect of terrain avoidance?
- ATC.
 - The ATSU when accepting the FP.
 - The PIC.
 - The Operator.

29. Which of the following statements regarding the Alerting Service is correct?
- The distress phase is established when an aircraft is known or believed to be the subject of unlawful interference.
 - Aircraft in the vicinity of an aircraft that is known or believed to be the subject of unlawful interference, shall be informed about this.
 - The Alerting Service and FIS are often provided by the same ATSU.
 - The Alert phase is established when no communication has been received from an aircraft within a period of 30 minutes after the time communications should have been received.
30. ATIS broadcasts for departing and arriving aircraft are to contain cloud cover information when:
- the cloud base is below 5,000 ft or the highest MSA whichever is higher.
 - the cloud base is below 3,000 ft or the highest MSA whichever is higher, or there is cumulonimbus reported.
 - the cloud base is below 5,000 ft or the highest MSA whichever is higher, or there is cumulonimbus reported.
 - the cloud base is below 10,000 ft or the highest MSA whichever is higher, or there is cumulonimbus reported.
31. ATIS broadcast:
- shall not be transmitted on the voice channel of a VOR beacon.
 - shall only be transmitted on a discrete VHF frequency.
 - shall not be transmitted on the voice channel of ILS.
 - shall be transmitted on the voice channel of ILS, on a discrete VHF frequency or on the voice channel of a VOR beacon.
32. Whenever ATIS is provided, the preparation and dissemination of the ATIS message is the responsibility of:
- the Met office serving the aerodrome.
 - both ATC and the Met office.
 - whichever office is prescribed by the state.
 - ATS.
33. Flight information provided to flights shall include provision of information concerning collision hazards to aircraft operating in airspace classes:
- F and G only.
 - C to G inclusive.
 - A to G inclusive.
 - A to E inclusive.
34. The phases of the Alerting Service to an aircraft in emergency or believed to be in emergency are:
- uncertainty phase; urgency phase; distress phase.
 - uncertainty phase; urgency phase; emergency phase.
 - uncertainty phase; alert phase; urgency and distress phase.
 - uncertainty phase; alert phase; distress phase.

35. The ATIS broadcast should not exceed:
- a. 3 minutes.
 - b. 30 seconds.
 - c. 1 minute.
 - d. 2 minutes.
36. An aerodrome Flight Information Service:
- a. can only relay ATC instructions to aircraft on the ground or in the air.
 - b. can supply limited services to the users but not ATC under any circumstances to aircraft in the air.
 - c. can supply ATC but is not subject to authority supervision.
 - d. is the same as ATC but is only provided at an aerodrome.

ANSWERS

Question	Answer	Reference
1.	A	6.72
2.	C	15.35
3.	B	15.32
4.	A	15.36
5.	D	15.38
6.	A	15.17
7.	B	15.5
8.	B	15.9
9.	D	15.33
10.	B	15.35
11.	C	15.38
12.	B	15.36
13.	C	15.28
14.	A	15.27
15.	D	15.15
16.	B	15.14
17.	C	15.12
18.	B	15.36
19.	A	15.5
20.	D	15.1
21.	D	15.41
22.	B	15.14
23.	D	15.19
24.	A	15.41
25.	A	15.3
26.	A	15.35
27.	C	15.33
28.	C	15.15
29.	C	15.35
30.	C	15.34
31.	C	15.32
32.	D	15.30
33.	B	15.27
34.	D	15.38
35.	B	15.33
36.	B	15.26

CHAPTER SIXTEEN

SEPARATION

Contents

CONCEPT OF SEPARATION.	265
VERTICAL SEPARATION	265
HORIZONTAL SEPARATION	267
RADAR SEPARATION	277
PROCEDURAL WAKE TURBULENCE SEPARATION	277
RADAR WAKE TURBULENCE SEPARATION.	282
VISUAL SEPARATION IN THE VICINITY OF AERODROMES	282
STACKING	286
QUESTIONS	288
ANSWERS	296

CONCEPT OF SEPARATION

16.1 General Provisions for the Separation of Controlled Traffic. Within CAS the ATC service will make sure that all controlled flights (flights provided with ATC) are separated from each other to comply with the first requirement of the service - to prevent collisions between aircraft. Separation can be either:

- Vertical or
- Horizontal or
- Composite (a mixture of both - see *Figure 16.3*)

It is applied to a defined standard, known as the separation minima. Separation is also applied to achieve spacing between aircraft to counter the effects of wake vortices and to facilitate timed arrivals and departures from busy aerodromes. Separation is applied:

- Between all flights in class A and B airspaces
- Between IFR flights in class C, D and E airspaces
- Between IFR flights and VFR flights in class C airspace
- Between IFR flights and special VFR flights
- Between special VFR flights, when so prescribed by the appropriate ATS authority

Note: IFR flights in VMC during daylight hours in classes D and E airspace may be cleared to climb and descend whilst maintaining own separation.

16.2 Minimum separation. Clearance will not be given to execute any manoeuvre that would reduce the spacing between two aircraft to less than the separation minimum applicable. Larger separations than the specified minima will be applied whenever wake turbulence or exceptional circumstances such as unlawful interference call for extra precautions. Whenever the type of separation or minimum used to separate two aircraft cannot be maintained, action shall be taken to ensure that another type of separation exists, or is established, when the previously applied separation becomes insufficient.

16.3 Composite Separation. In circumstances where (usually due to an emergency or a serious deterioration in operating capability) the aircraft cannot maintain the necessary requirements for normal navigation, a compromise separation standard may be specified (in accordance with a RAN agreement), whereby the aircraft will take up altitude and track spacing not less half that specified in the standards for normal separation. The RTF failure procedure for the NAT region specifies composite separation; likewise, the suggested procedure for unlawful interference where the pilot cannot maintain two-way RTF also specifies composite separation.

16.4 Essential Traffic Information. Essential Traffic is defined as that controlled traffic to which ATC separation is applicable but to which in relation to another controlled flight is not, or will not, be separated by the required minimum. 'Essential traffic information' will be passed to the controlled flights concerned when they constitute essential traffic to each other.

VERTICAL SEPARATION

16.5 Vertical Separation Minima. Wherever possible, ATC will arrange vertical separation to maximise the use of airspace and minimise horizontal use of airspace. Vertical separation is obtained by requiring aircraft using the same altimeter setting to fly at different levels expressed in terms of flight levels or altitudes dependant upon the magnetic track of the aircraft. The vertical separation minimum (VSM) is:

- Within designated airspace (subject to RAN agreement (RVSM)), a nominal 300m (1,000 ft) below FL 410 or a higher level where so prescribed for use under specified conditions, and a nominal 600m (2,000 ft) at or above this level; and
- Within all other airspace : a nominal 300m (1,000 ft) below FL290 and a nominal 600m (2,000 ft) at or above this level.

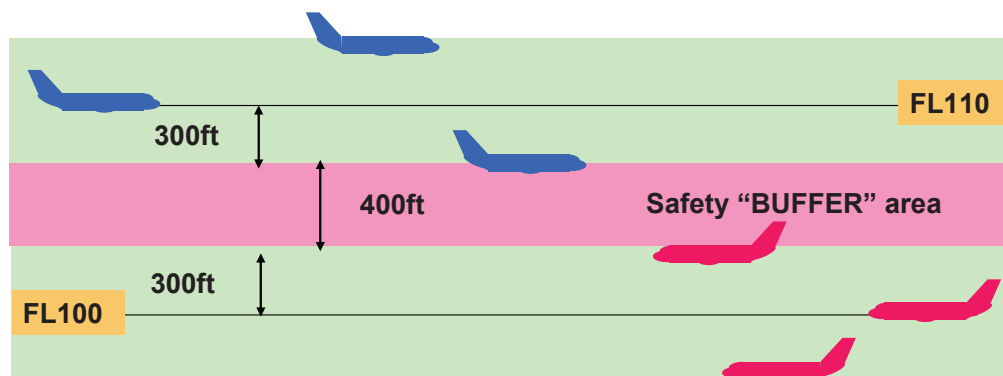

ICAO LEVEL OCCUPANCY STANDARD = +/- 300ft
(UK applies +/- 200 ft standard)

Figure 16.1: ICAO level occupancy standard.

16.6 RVSM Cruising Levels. The RVSM cruising levels defined for domestic airspace (outside of the NAT MNPSA) are those between FL290 and FL410 inclusive. In other words, both FL290 and FL410 are RVSM levels.

16.7 Minimum cruising level. Except when specifically authorised by the appropriate authority, cruising levels below the minimum flight altitudes (established by the State) shall not be assigned. Area Control Centres shall, when circumstances warrant it, determine the lowest useable flight level or levels for the whole or parts of the control area for which they are responsible, and use it when assigning flight levels and pass it to pilots on request. Unless otherwise prescribed by the State concerned, the lowest usable flight level is that which corresponds to, or is immediately above, the established minimum flight altitude. The portion of a control area for which a particular lowest usable flight level applies is determined in accordance with air traffic services requirements.

16.8 Assignment of Cruising Level. An ACC will normally allocate only one cruising level to an aeroplane (except where cruise climb is authorised), for flight in the control area or for flight entering another control area.

16.9 Level Change. If a change in cruising level is required, the aircraft is to request a level change en route (after initial clearance received). Aircraft, cruise climb authorised, will be cleared to operate between two levels. On ATS routes (airways) extending beyond the control area, level changes are to be effected over a radio navigation aid. If an aircraft has been cleared into a CTA below the minimum cruising level for that airspace, the ACC will issue a clearance to climb even though the pilot has not requested it. When necessary, an aircraft may be cleared to change cruising level at a specified time, place or rate.

16.10 Same Destination. If practicable, cruising levels of aircraft bound for the same destination will be assigned to facilitate the correct approach sequence at the destination.

16.11 Priority. An aircraft at a cruising level will have priority over aircraft requesting that level. When two or more aircraft are at the same level, the preceding aircraft will have priority

16.12 Allocation Separation. An aircraft may be assigned a level previously occupied by another aircraft after the latter has reported vacating it. In the case of severe turbulence or cruise climb, the assignment will be withheld until the other aircraft has reported at another level separated by the required minimum.

16.13 Vertical separation during ascent or descent. Pilots in direct communication with each other may, with their concurrence, be cleared to maintain a specified vertical separation between their aircraft during ascent or descent.

16.14 Clearance to Maintain Own Separation in VMC. If requested by the pilot of an aircraft and it is agreed by the pilot of the other aircraft and authorised by ATC, a flight operating in classes D and E airspace in VMC during daylight, may be cleared to climb or descend maintaining own separation from one other aircraft providing:

- The clearance is specifically for the portion of flight below 10,000 ft;
- Alternative instructions are passed to the pilot to cover loss of VMC;
- If conditions deteriorate to the limits of VMC, the pilot is to inform ATC that he/she is complying with the alternate instructions.

HORIZONTAL SEPARATION

16.15 Definition. Horizontal separation relates to the distance between aircraft in the horizontal plane. This may be:

- Longitudinal (aircraft following the same route), where the separation standard is based on time (or distance) along track between aircraft, or
- Lateral.

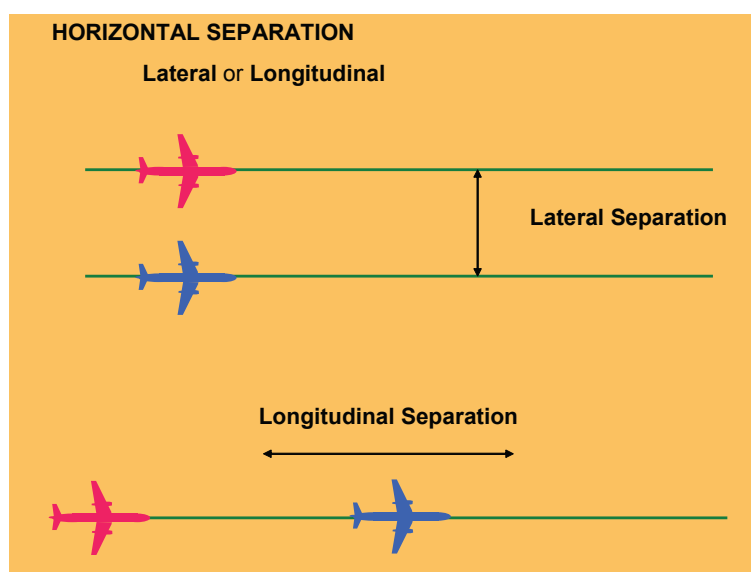

Figure 16.2:

16.16 Lateral Separation. Lateral separation shall be applied so that the distance between those portions of the intended routes for which the aircraft are to be laterally separated is never less than an established distance to account for navigational inaccuracies plus a specified buffer. This buffer shall be determined by the appropriate authority and included in the lateral separation minima. Lateral separation of aircraft at the same level is obtained by requiring operation on different routes or in different geographical locations as determined by visual observation, by use of navigation aids or by use of area navigation (RNAV) equipment. The 'buffer' concept is applied to all methods of separation.

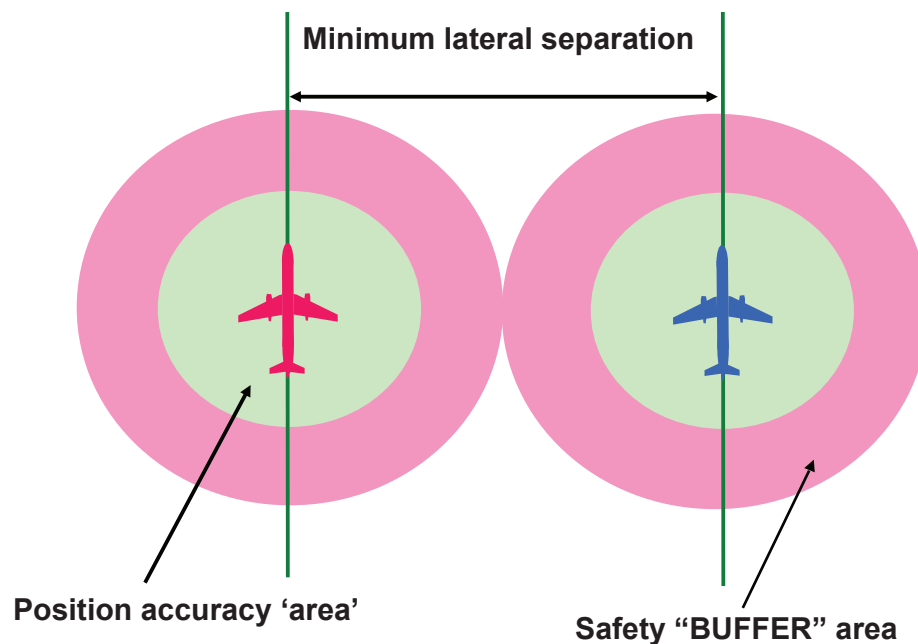

Figure 16.3:

16.17 Lateral Separation Criteria and Minima. Means by which lateral separation may be achieved include the following:

- **Geographical Separation.** Separation positively indicated by position reports over different geographical locations as determined visually or by reference to a navigation aid.
- **Track Separation.** This can be achieved between aircraft using the same navigation aid or method. It is achieved by requiring aircraft to fly on specified tracks which are separated by a minimum amount (angle and distance) appropriate to the navigation aid or method employed as follows. For the three cases specified the distance required is 15nm from the common position with track divergence as follows:
 - VOR: Track divergence 15°
 - NDB: Track divergence 30°
 - DR Fix: Track divergence 45°

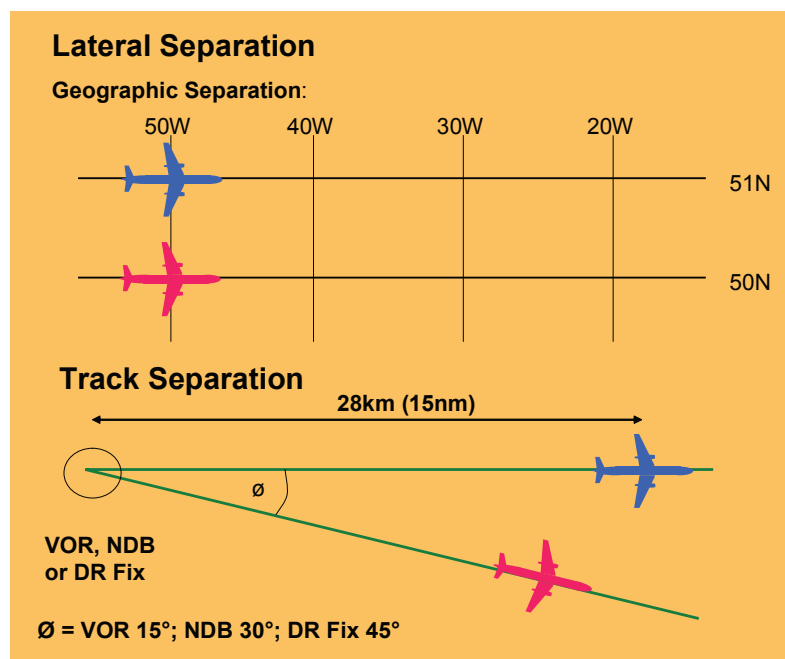

Figure 16.4: Lateral separation.

16.18 Different Navigation Aids. Lateral separation between aircraft using different navigation aids, or where one aircraft is using RNAV equipment, is to be established by ensuring that the derived protected airspaces (buffer areas) do not overlap.

16.19 RNAV Operations. Within designated airspace or on parallel routes where RNP is specified, lateral separation between RNAV aircraft may be obtained by requiring aircraft to be established on the centre lines of parallel tracks or ATS routes spaced at a distance which ensures that the protected airspaces do not overlap. This is the policy that determines the spacing of the NAT tracks employed in the NAT MNPSA.

16.20 Longitudinal Separation. Longitudinal separation is the most complex application of separation standards. In procedural ATC (not radar control) the position of the aircraft is that which is reported by the pilot. The positions reported are usually specified reporting points, radio navigation facilities, or geographic points for routes not specified by navigation aids. In any event, the position known to the ATCO is only as good as that reported by the pilot. In applying procedural separation, all possible errors must be allowed for and then a safety margin (buffer) applied. The only situation in which the safety margins may be relaxed is where the pilots of aircraft to which separation should be applied have (and confirmed) that they have visual contact with each other and that they can maintain visual contact during the necessary manoeuvre to which separation would otherwise be applied. Clearly, the separation standards assume operations in IMC. The accuracy of pilot position reporting relies on the accuracy of the navigation system in use. In remote areas (over the oceans and desert regions) where RNAV procedures may be used, greater protection needs to be applied. Longitudinal separation applied is either in terms of time or distance.

16.21 Application. Longitudinal separation is applied so that the spacing between the estimated positions of the aircraft being separated is never less than a prescribed minimum. Longitudinal separation between aircraft following the same or diverging tracks may be maintained by application of the Mach number technique, when so prescribed on the basis of RAN agreement. Longitudinal separation is established by requiring aircraft to depart at a specific time, to lose time, to arrive over a geographical location at a specified time, or to hold over a geographical location until a specified time. For the purpose of the application of longitudinal separation, the following terms are defined:

- **Same Track.** The same track case applies when the tracks of two aircraft that require separation, converge or diverge by an angular difference less than 45° , or more than 315° and whose protection areas overlap.
- **Reciprocal Track.** The reciprocal track case applies when the tracks of two aircraft that require separation, converge or diverge by an angular difference more than 135° but less than 225° and whose protection areas overlap.
- **Crossing Track.** Crossing tracks are defined as tracks which intersect at angles other than those defined in a. or b. above.

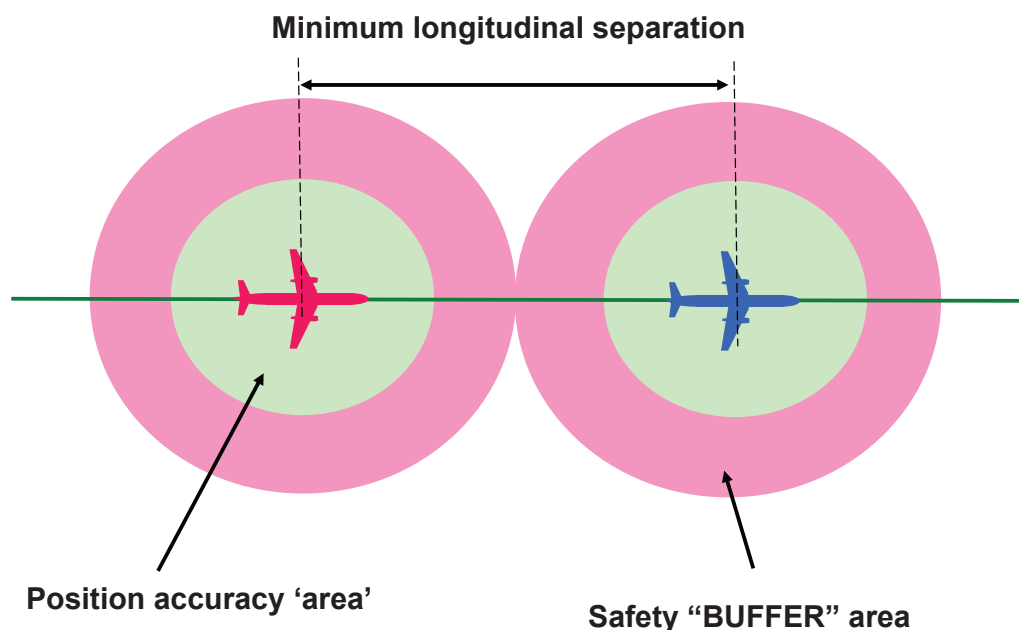

Figure 16.5: Longitudinal separation.

16.22 Time Based Longitudinal Separation. The separation standards applied depends upon whether the aircraft concerned are maintaining the same level, or are climbing/descending.

16.23 Same Level. In this situation the separation is dependant upon the track case:

- **Same track case.** The basic standard is that aircraft should be at least 15 minutes apart. If, however, navigation aids for the route being flown permit frequent determination of position and speed the basic standard may be reduced to 10 minutes. The standard may be further reduced to 5 minutes providing the aircraft have departed from the same aerodrome, or passed over the same en-route reporting point, or reported over a fix that is located relative to the departure point, to ensure that 5 minutes separation can be

established at the point the departing aircraft will join the route, with the overriding proviso that the preceding aircraft has TAS 20 kts or more faster than the succeeding aircraft. If the speed difference is increased to 40 kts, the standard may be further reduced to 3 minutes.

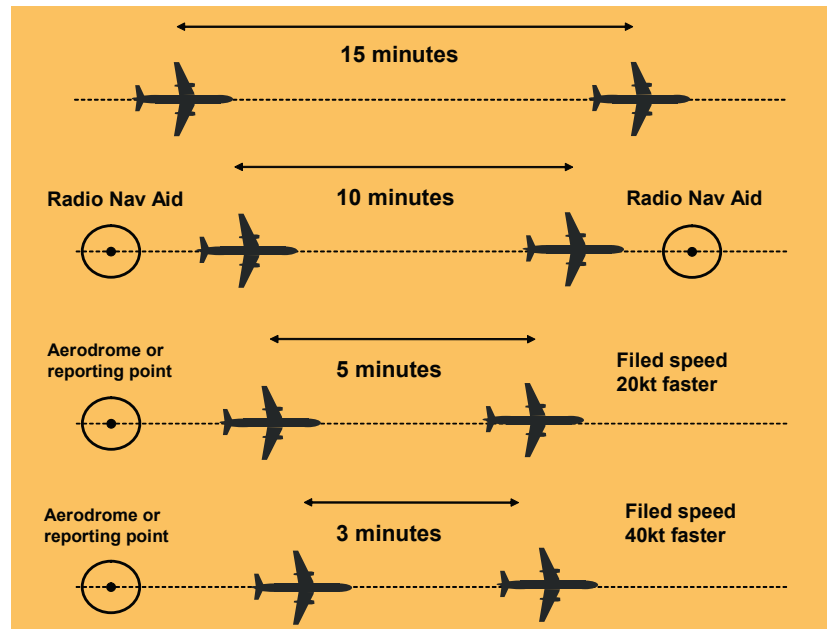

Figure 16.6:

- **Crossing track case.** The basic standard is 15 minutes. If however, the frequent determination of position and speed caveat applies, the standard may be reduced to 10 minutes.

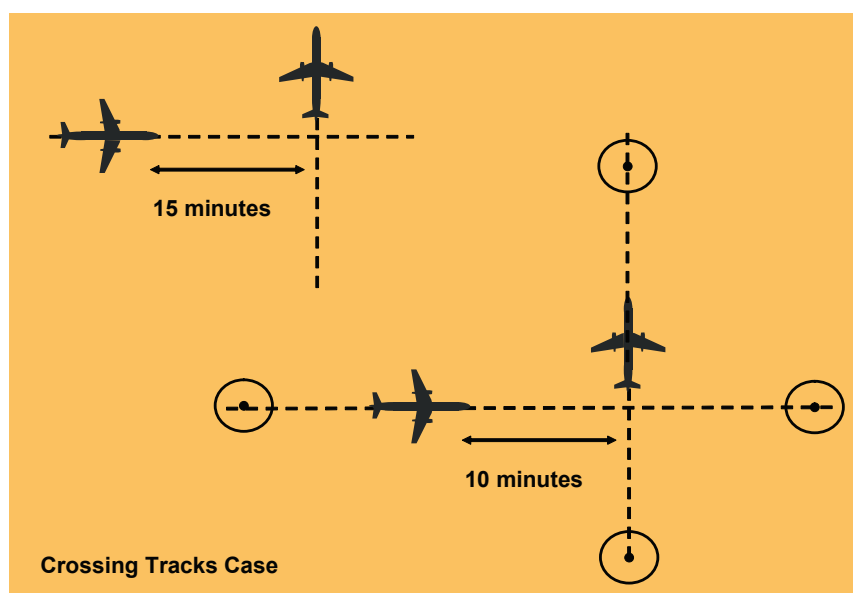

Figure 16.7:

16.24 Climbing or descending. This is a more complex case. The problem only exists when vertical separation does not exist (the aircraft are within the vertical separation standard of each other). Again it depends upon the relative tracks of the aeroplanes but now also involves the reciprocal track case.

- **Same track.** When an aircraft will pass through the level of another aircraft on the same track, the separation applied is 15 minutes, but may be reduced to 10 minutes provided that navigation aids permit frequent update of position and speed (and approved by the authority); or 5 minutes provided that the level change is commenced within 10 minutes of the time that the second aircraft has reported over an exact reporting point.

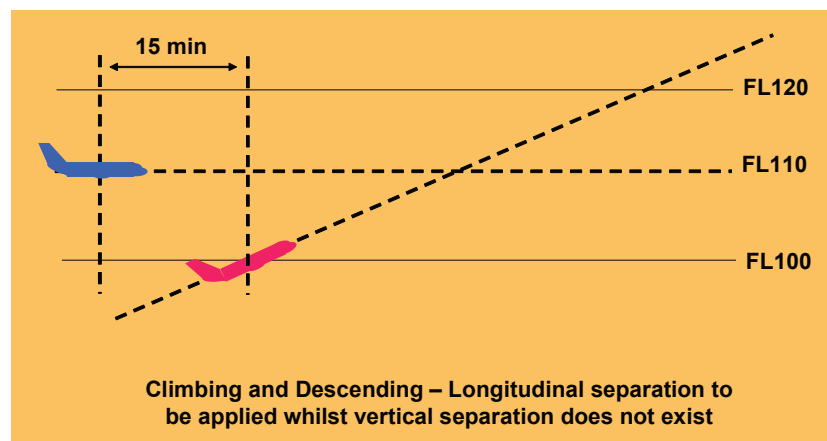

Figure 16.8:

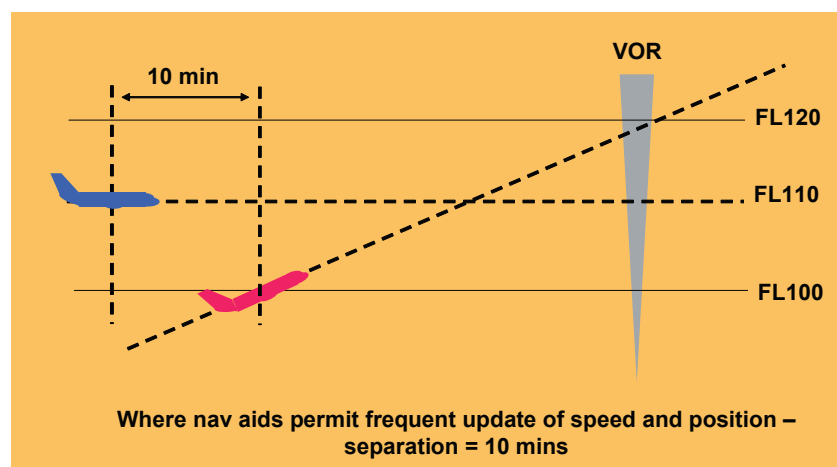

Figure 16.9:

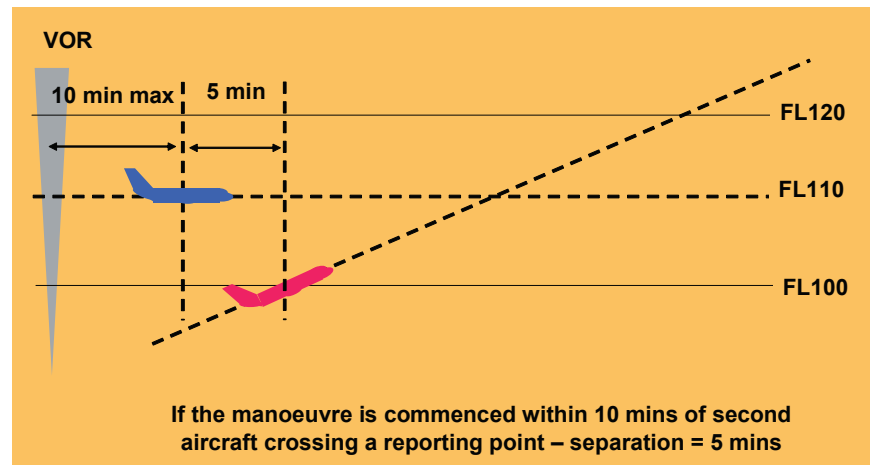

Figure 16.10:

Note: If the level change involved is considerable, an intermediate level just above or just below (depending on the case - climb or descend) may be allocated to the manoeuvring traffic. Once at that level, separation will be assessed and if applied, the level crossing manoeuvre approved and executed.

- **Crossing tracks.** The applicable standard is 15 minutes unless frequent update of position and speed is available, in which case the minimum is reduced to 10 minutes.
- **Reciprocal tracks.** Where lateral separation is not provided, vertical separation shall be provided for at least 10 minutes prior to and after the time the aircraft are estimated to have passed. Once it has been established (usually visually) that the aircraft have indeed passed, this minimum need not then further apply.

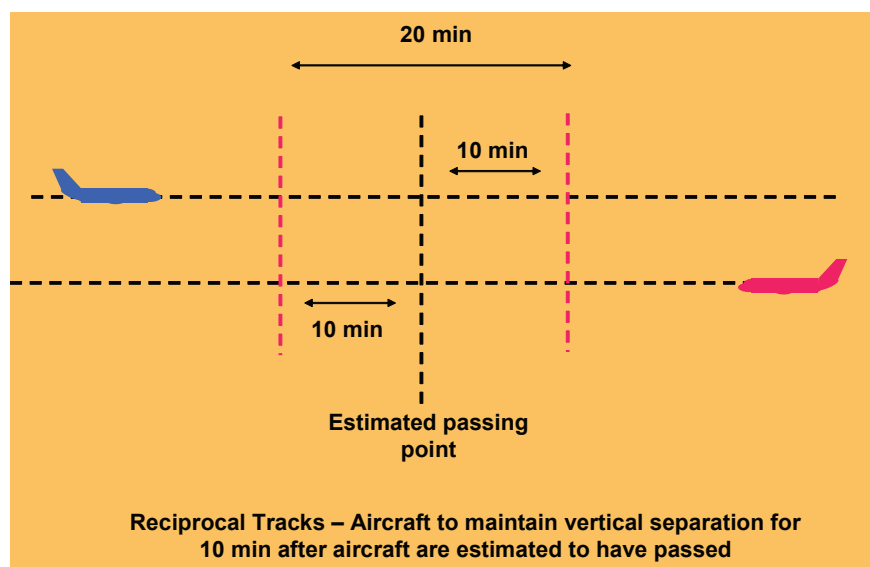

Figure 16.11:

16.25 Longitudinal separation based on DME. Where DME information is available, separation can be established by maintaining not less than the specified distances between aircraft positions. In this case it is a requirement that direct pilot - controller communication is maintained.

Note: in the NAT region using HF, communication is via a radio operator not direct to the controller.

16.26 Aircraft at the same level. The previously defined same and crossing track situations apply:

- **Same track.** The normal standard is 20 nm provided each aircraft uses on-track DME stations and separation is checked by obtaining simultaneous DME readings from the aircraft at frequent intervals. The standard may be reduced to 10 nm provided the leading aircraft maintains a TAS 20 kts or more, faster than the succeeding aircraft.
- **Crossing tracks.** The same track standards apply to crossing traffic providing that each aircraft reports distance from the station located at the crossing point and that the relative angle of the tracks is less than 90°.
- **Climbing or descending.** The standard separation is 10 nm whilst vertical separation does not exist, providing each aircraft uses 'on-track' DME stations; one aircraft maintains a level whilst vertical separation does not exist, and separation is established by simultaneous DME readings from the aircraft.
- **Reciprocal tracks.** Aircraft using on-track DME may be cleared to climb or descend to or through levels occupied by other aircraft using on-track DME, provided it has been positively established that the aircraft have passed each other and are at least 10 nm apart (or such other value as the authority specifies).

16.27 Longitudinal separation with Mach number technique based on time. The Mach number technique requires turbojet aircraft to fly at the Mach number approved by ATC, and to request approval before making any speed changes. If it is essential to make immediate temporary changes to speed (e.g. due to turbulence), ATC is to be informed as soon as possible. If it is not feasible due to aircraft performance to maintain the last assigned Mach no during en route climbs and descents, pilots are to advise ATC at the time clearance to climb or descent is requested. Separation will be deemed to exist when the required time interval exists providing:

- The aircraft concerned have reported over the same reporting point and follow the same track or continuously diverging tracks until some other form of separation is provided, or
- It is possible to ensure, by radar or other means that the appropriate time interval will exist at the common point from which they will either follow the same track or continuously diverge, if the aircraft have not already reported over the same point.

16.28 Time intervals. When the Mach number technique is applied, minimum longitudinal separation between turbojet aircraft on the same track, whether in level, climbing or descending flight is:

- 10 minutes providing the preceding aircraft maintains a Mach speed equal to or greater than that maintained by the following aircraft, or

- Between 9 and 5 minutes inclusive, providing the preceding aircraft is maintaining a Mach no greater than the following aircraft in accordance with the following:

Mach No difference between preceding and following	Longitudinal Separation standard
0	10 minutes
0.01	10 minutes
0.02	9 minutes
0.03	8 minutes
0.04	7 minutes
0.05	6 minutes
0.06	5 minutes

Figure 16.12: Mach number separation.

16.29 Longitudinal Separation based on RNAV. This is applicable to RNAV aircraft operating along RNAV routes or ATS routes defined by VOR. In this case, separation is established by maintaining the specified distance between aircraft positions reported by reference to the RNAV equipment. It is a requirement that direct controller/pilot communications are maintained. RNAV positions are defined as standard way points common to both aircraft subject to separation. The minimum is 150 km (80 nm) distance based separation instead of the normally required 10 minutes. It is also essential that the Mach no technique is applied. In the event of equipment failure reducing the navigation capability to less than the RNAV requirement, the normal longitudinal separation will be applied. The specific separation requirements are:

- **Same cruising level.** 150 km (80 nm) providing each aircraft reports position from same point and separation is checked by obtaining simultaneous RNAV distance readings from the aircraft at frequent intervals.
- **Climbing or descending on same track.** 150 km (80 nm) whilst vertical separation does not exist, provided each aircraft reports distance from same way point, one aircraft maintains level flight whilst vertical separation does not exist, and separation is established by obtaining simultaneous RNAV distance readings from the aircraft.
- **Reciprocal tracks.** Aircraft may be permitted climb or descend through levels occupied by other aircraft providing it has been positively established by simultaneous RNAV distance readings to or from the same on-track way point that the aircraft have passed each other by at least 150 km (80 nm).

16.30 Longitudinal Separation based on RNAV where RNP is specified. For aircraft cruising, climbing or descending on the same track in an RNP RNAV environment, the separation standards detailed in the table below may be used. During the application of the 50 nm minimum, if an aircraft fails to report its position, the controller is to take action within 3 minutes to establish communications. If communication has not been established within 8 minutes alternative separation is to be applied. An aircraft may climb or descend through an occupied level once it has been established that the aircraft concerned have passed.

RNP Type	Communication Requirement	Surveillance Requirement	Distance Verification Requirement	Separation
20	Direct pilot/controller communications	Procedural Position Reports	At least every 60 minutes	80 nm
10	Direct pilot/controller communications	Procedural Position Reports	At least every 30 minutes	50nm

Figure 16.13: RNP RNAV separation.

16.31 Reduction in separation minima. The separation minima may be reduced as determined by the appropriate ATS authority, after prior consultation with the aircraft operators, as appropriate, in the following circumstances:

- When special electronic or other aids enable the pilot-in-command of an aircraft to determine accurately the aircraft's position and when adequate communication facilities exist for that position to be transmitted without delay to the appropriate air traffic control unit; or
- When, in association with rapid and reliable communication facilities, radar-derived information of an aircraft's position is available to the appropriate air traffic control unit; or
- When special electronic or other aids enable the air traffic controller to predict rapidly and accurately the flight paths of an aircraft and adequate facilities exist to verify frequently the actual aircraft positions with the predicted positions; or
- When RNAV-equipped aircraft operate within the coverage of electronic aids that provide the necessary updates to maintain navigational accuracy.
- In accordance with RAN agreements, after prior consultation with the aircraft operators, when:
 - Special electronic, area navigation or other aids enable the aircraft to closely adhere to their current flight plans; and
 - The air traffic situation is such that the conditions regarding communications between pilots and the appropriate ATS unit or units need not necessarily be met to the degree specified therein, in order to maintain an adequate level of safety.

RADAR SEPARATION

16.32 Separation minima. Radar provides the ATCO with fairly accurate position information for an aircraft under his/her control. Problems associated with radar include: slant range display, target discrimination and loss of contact close to the radar overhead. These 'errors' must be handled in the same manner that other positional errors are: by the addition of 'buffer' allowances. The errors are worse for long range radars used in area control but must still be considered for terminal radars covering a much smaller area. The basic radar separation standard is 5nm. This means that where two aircraft identified on radar are at the same level, they are not permitted to approach closer than 5nm to each other on the radar display.

16.33 Reduced Radar Separation. When approved by the authority and in specific circumstances, the radar separation standard (5nm) may be reduced. The following describe these specific occasions:

- **Terminal Radar within 40nm of the Radar Head.** In this situation (usually where procedures are employed by an Approach Radar Controller) and the aircraft is within 40nm of the position of the radar transmitter (head), the separation standard may be reduced to 3nm between contacts on the radar display.
- **ILS Localiser.** Where two (or more) aircraft are established on the same ILS localiser course and within 10 nm of the threshold of the landing runway, the separation standard may be reduced to 2.5nm between contacts on the radar display.
- **Simultaneous Parallel Approaches (Mode 2 - Dependent).** During Mode 2 parallel runway operations radar separation is applied. Between aircraft on adjacent localiser courses the separation standard may be reduced to 2nm between contacts on the radar display.

PROCEDURAL WAKE TURBULENCE SEPARATION



Figure 16.14:

16.34 Situation. When the wings are creating lift (from 'rotate' to 'touchdown'), wake vortices are created behind the aircraft. This is apparent in the form of turbulence, the severity of which is a function of aircraft mass, the worst case being a heavy aircraft at low speed. Where

an aircraft is following another aircraft, allowance must be made for the 'wake turbulence effect' which under certain circumstance can be so severe as to cause structural damage (even catastrophic damage) to an airframe. The nature of the wake vortex is that it emanates from the wing tip in the form of spiraling air from the high pressure area below the wing to the low pressure area above the wing. It spirals 'in board' towards the fuselage. The vortex exists at the level of the generating aircraft and to an altitude not exceeding 1,000 ft below the generating aircraft. Where the following aircraft is within this airspace, wake turbulence separation must be applied.

16.35 Wake Turbulence Categories. Aircraft are categorised by maximum take off mass (MTOM) to relate to the severity of the wake vortices generated. There are three categories as follows:

- **Heavy** - all aircraft types with MTOM equal to 136,000 kg or more
- **Medium** - aircraft types with MTOM less than 136,000 kg but more than 7,000kg
- **Light** - aircraft types with MTOM of 7,000 kg or less

Note: MTOM is stated on the Certificate of Airworthiness for the aircraft.

16.36 Separation Minima. The following procedural (non-radar) wake turbulence separation is applied. Note the criteria are only applicable where the following aircraft is 'lighter' than the preceding aircraft.

16.37 Arriving Aircraft. timed approaches:

- Medium behind a heavy - 2 minutes
- Light behind a medium or heavy - 3 minutes

16.38 Departing Aircraft. For a light or medium taking off behind a heavy, or a light behind a medium, a minimum of 2 minutes is applied when they are using:

- The same runway;
- Parallel runways separated by less than 760 m;
- Crossing runways if the projected flight paths cross at the same altitude or within 1,000 ft below the higher;
- Parallel runways separated by 760 m or more if the projected flight paths cross at the same altitude or within 1,000 ft below the hig

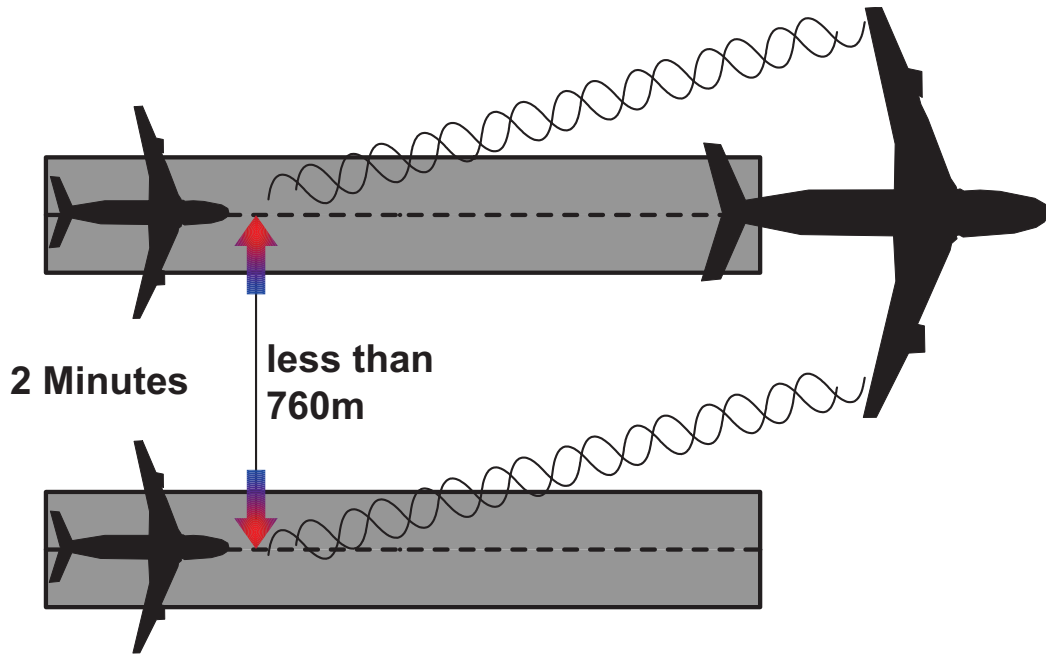

Figure 16.15: Parallel runways.

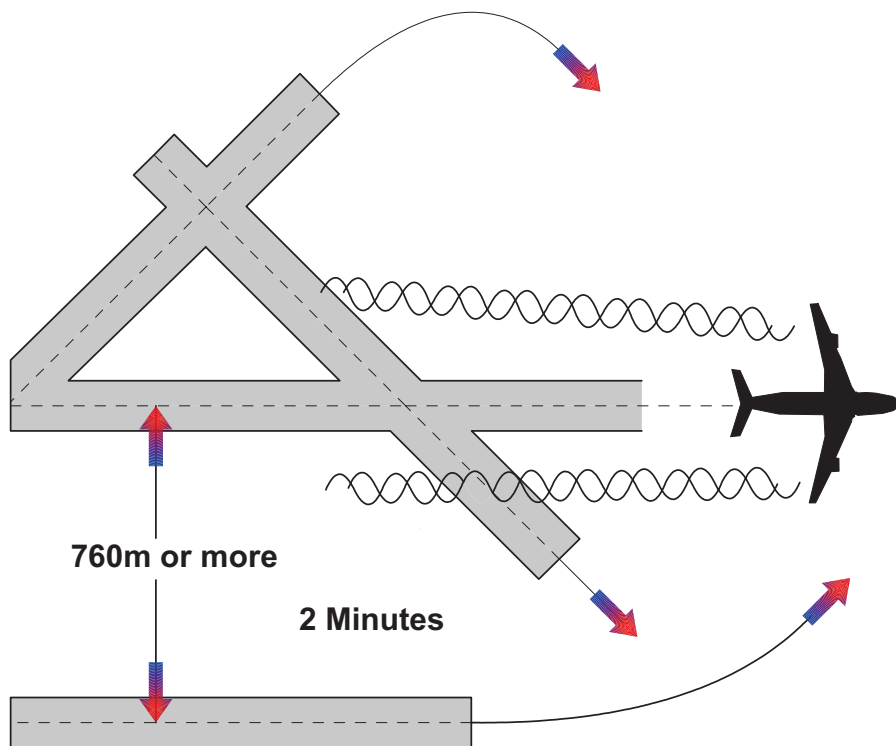

Figure 16.16: Parallel and crossing runways.

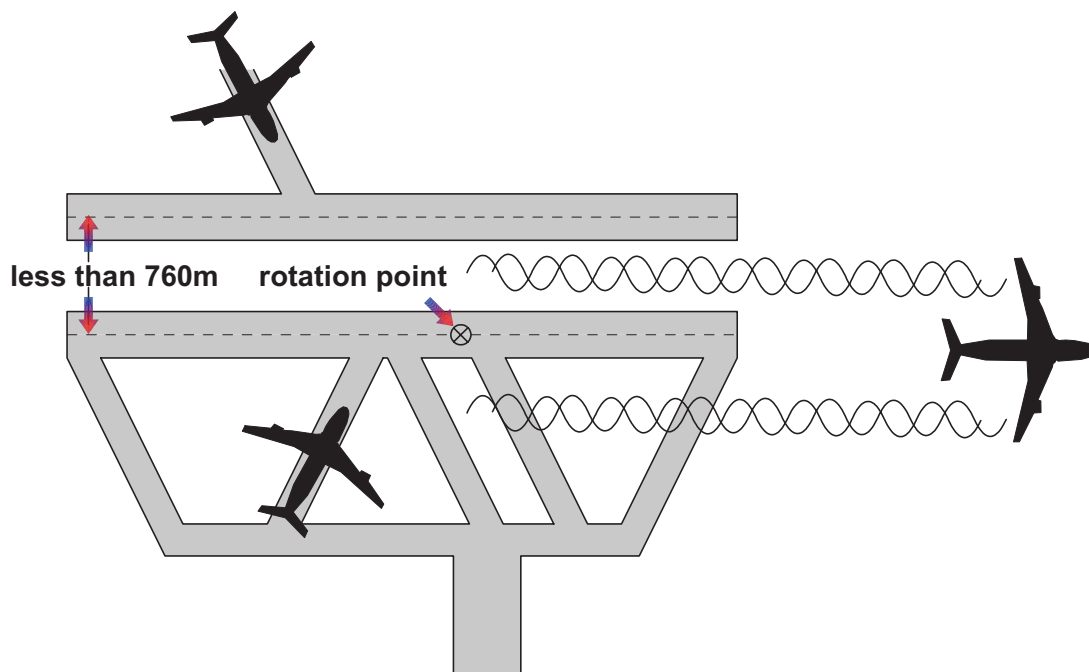

Figure 16.17: Intermediate take off.

Note: Separation is increased to 3 minutes where a light or medium is taking off behind a heavy (or light behind a medium) from an intermediate part of the same runway or an intermediate point on parallel runways.

16.39 Displaced landing threshold. A separation of 2 minutes is applied between light or medium and heavy (or between light and medium) when operating on a runway with a displaced threshold when:

- A departing light or medium follows a heavy arriving, or a departing light follows a medium arriving, or
- An arriving light or medium follows a heavy departing, or an arriving light follows a medium departing, if the projected flight paths are expected to cross.

16.40 Opposite direction. A separation of 2 minutes is applied between a light or medium and a heavy, or between a light and a medium, when the heavier aircraft is making a low or missed approach and the lighter aircraft is using an opposite direction runway for take-off, or is landing on the same runway in the opposite direction, or on a parallel opposite direction runway separated by less than 760 m.

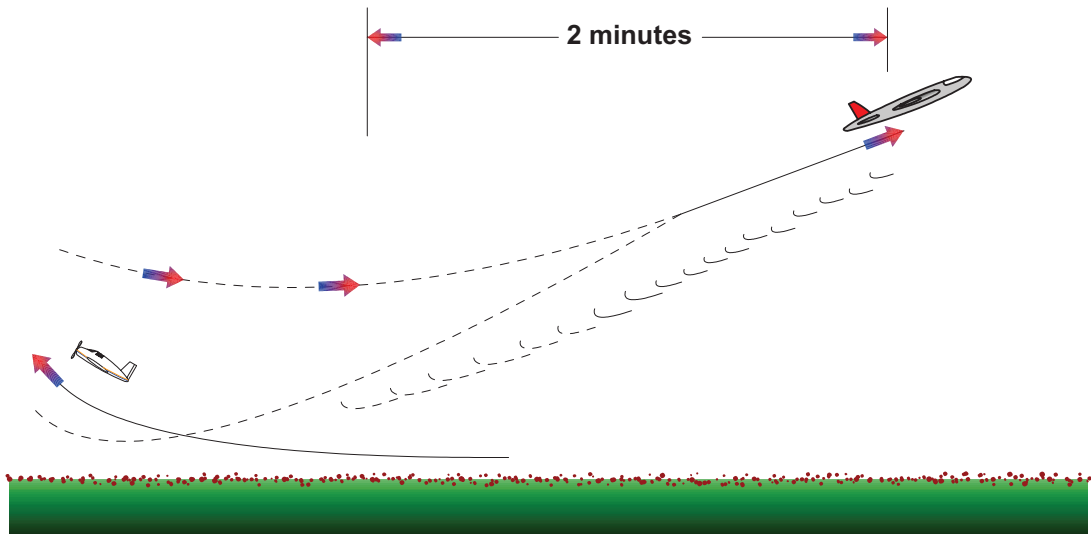

Figure 16.18: Opposite direction for take off.

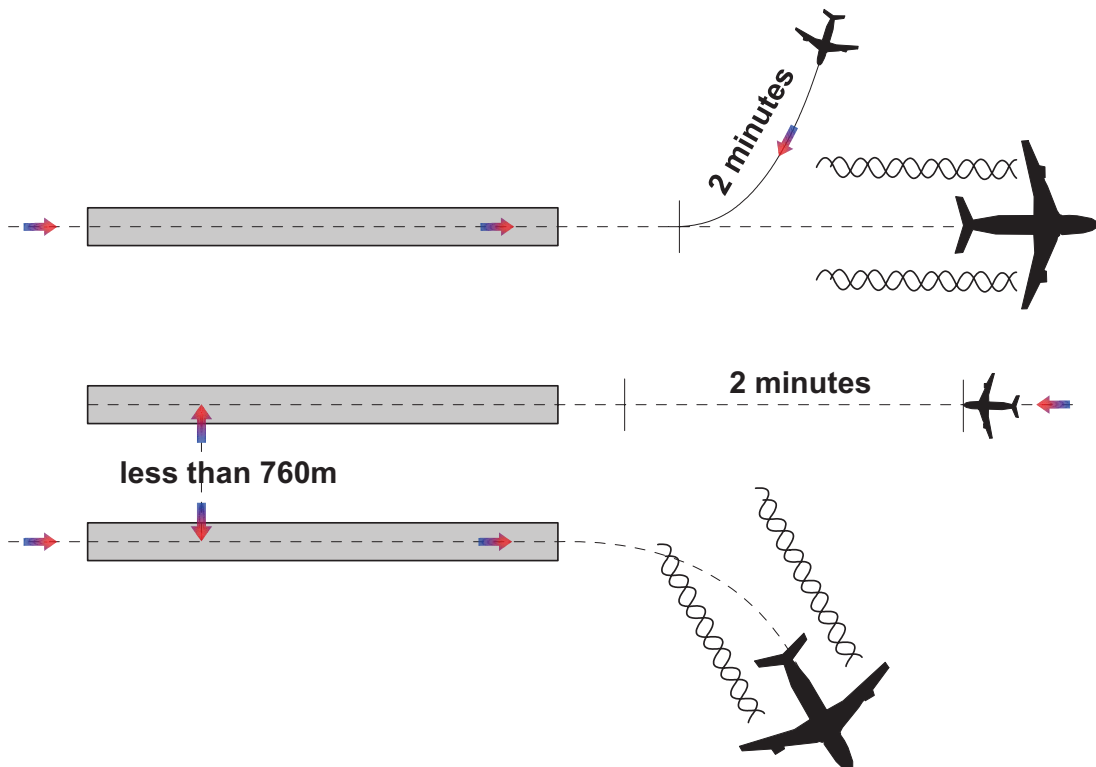

Figure 16.19: Opposite direction for landing.

16.41 Indication of Heavy category. Because of the inherent problems caused by heavy wake turbulence category aircraft requiring additional separation, pilots of heavy category aircraft are to indicate the aircraft's heavy category in the **initial** RTF contact with an ATCU by the inclusion of the suffix "heavy" to the identifying call sign of the aircraft. e.g. *"London Control this is Speedbird 216 heavy on 133.650"*

RADAR WAKE TURBULENCE SEPARATION

16.42 Radar Wake Turbulence Separation. Because the position of the aircraft is displayed to the controller, the required separation for wake turbulence in this case is expressed in distance. The table below contains the wake turbulence radar separation minima specified by ICAO which will be applied to aircraft in the approach and departure phases of flight. Note that in this case the criteria apply where the category of the following aircraft is lighter than the leading aircraft, except for the heavy/heavy case.

Aircraft Wake Turbulence category		
Leading Aircraft	Following Aircraft	Separation
Heavy	Heavy	4 nm
Heavy	Medium	5 nm
Heavy	Light	6 nm
Medium	Light	5 nm

Figure 16.20: Radar wake turbulence separation criteria.

VISUAL SEPARATION IN THE VICINITY OF AERODROMES

16.43 Introduction. Except in condition where 'Low Visibility' operations are in progress at an aerodrome, traffic flying in the vicinity of the aerodrome including arriving, departing and local area traffic, will be flying in condition which will either permit VFR or pilots of aircraft to maintain separation from other aircraft visually. The importance of this cannot be overstressed as the application of visual separation not only relieves the ATCO of having to impose either procedural or radar separation, but permits minimum runway occupancy time, 'land after' procedures and multiple aircraft flying in the visual traffic pattern. In effect, the application of visual separation increases aerodrome capacity and hence aerodrome utilisation. Typically, Heathrow has the capacity to accommodate about 60 take off operations and 60 landing operations per hour and at peak time the traffic load gets close to this. If procedural or radar separation had to be applied to the arrival or departure phases of operations, the utilisation would reduce dramatically. The standards previously mentioned can be reduced if:

- Adequate separation can be provided by the aerodrome controller when each aircraft is continuously visible to the controller, or
- Flight crews report that they have visual contact with other aircraft and this can be maintained; or

- In the case of one aircraft following another, the crew of the following aircraft report that the leading aircraft is within sight and that separation can be maintained.

16.44 Essential Local Traffic. Any aircraft, vehicle or personnel on or near the runway, or traffic in the take-off and climb out areas or the final approach area, which may constitute a collision hazard to a departing or arriving aircraft is defined as essential local traffic. Where essential local traffic is known to the controller the information is to be transmitted to flight crews without delay.

16.45 Departing Aircraft. Under IFR, departing aircraft will normally be separated from each other by requiring the aircraft to follow a SID. ATCUs will co-ordinate the issuing of clearances, and where possible, standard clearances will be used. Such clearances will normally be specified by the approach controller and passed to the aircraft by the aerodrome control tower. For departures in VMC, the aerodrome controller will clear an aircraft for take off once the preceding aircraft has either:

- Passed the upwind end of the runway, or
- Has made a turn away from the runway.

Where wake turbulence separation is applied, departures will be sequenced to minimise delays and maximise runway utilisation. For IFR traffic, the standard separation between departures is 5 minutes (12 movements per hour). This may be reduced to 2 minutes between aircraft following the same departure track providing the preceding aircraft has filed a FP speed 40kts greater than the succeeding aircraft. This may further be reduced to 1 minute (60 movements per hour) providing the track of the succeeding aircraft diverges from that of the preceding aircraft by 45° or more. Obviously, where parallel runways are used for simultaneous take-offs, or diverging runways are used, higher utilisation rates (lower separation) may be achieved.

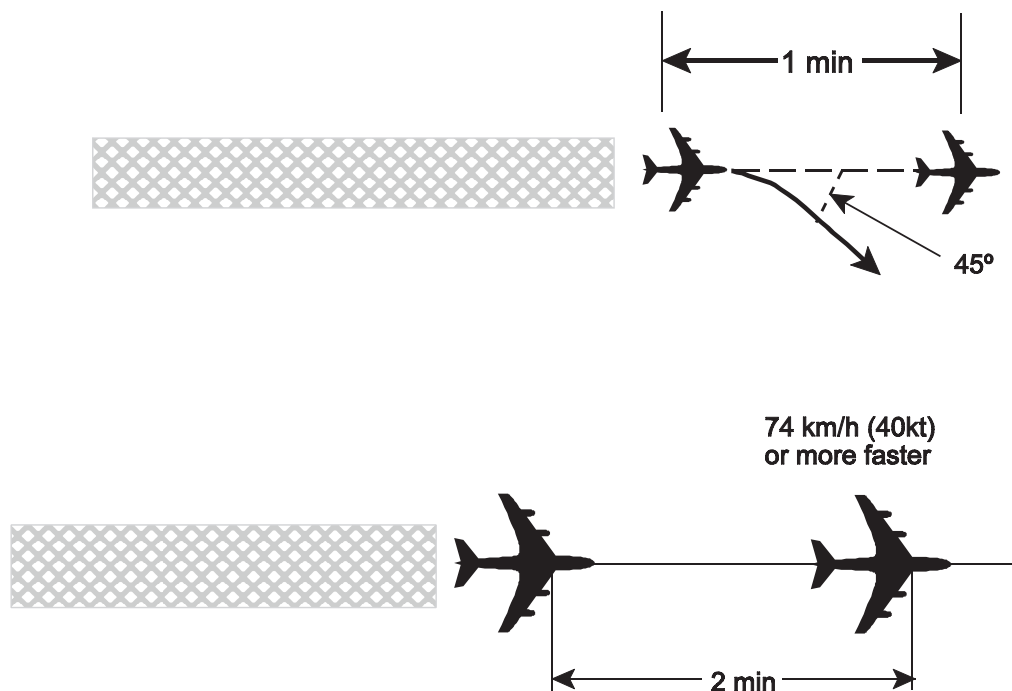

Figure 16.21:

16.46 Departure Sequence. At busy aerodromes, the ground movement of aircraft will be planned to ensure that the stated Off Blocks Time can be translated into the necessary slot time for the aircraft. This is the job of the Ground Movements Planner working for the aerodrome controller. If correctly sequenced, the aircraft will arrive at the holding point (or holding area) in the correct order for take off. Consideration will also be given to the route of the aircraft immediately after take-off to minimise wake turbulence separation. Departure may be expedited by suggesting a take-off direction that is not into wind. In this case, the PIC is to make the decision if this is acceptable.

16.47 Delays. It is inevitable that at some point a delay will occur. In which case, flights may be cleared to take-off in an order based on the estimated departure time. Deviation from this may be made to facilitate the maximum number of departures with the least average delay, or in response to requests from operators if possible. ATCUs should inform operators when anticipated delays exceed 30 minutes.

16.48 Arriving Aircraft. Arriving IFR aircraft may be cleared to make a visual approach provided that:

- The pilot can maintain visual reference to terrain; and
- The reported ceiling is at or above the approved initial approach level; or
- The pilot reports that at any time during an instrument approach the meteorological conditions are such that there is a reasonable assurance that an approach and landing will be made visually.

16.49 Separation. ATC will provide separation between aircraft making a visual approach and all other arriving or departing traffic. For arriving IFR traffic (in IMC) the Approach Controller will transfer control of the aircraft to the Aerodrome Controller at a point during the approach so that separation from departing traffic can be achieved and sufficient time is available to issue a landing clearance. For certain types of approach (PAR or SRA) the aircraft will remain under control of the Approach Radar Controller throughout the approach. This will necessitate the radar controller obtaining the landing clearance and passing it to the pilot during the latter stages of the approach. The Aerodrome Controller in co-operation with the Approach Controller will be responsible for sequencing departures during low visibility IFR operations. Two situations are considered:

- **Complete Procedure.** If an arriving aircraft is making a complete instrument approach, departing traffic will not be permitted to take off in any direction after the instrument traffic has started the procedure or base turn to final or after the aircraft has started a procedure turn and there will be at least 3 minutes between the departure and the time the arriving aircraft is over the threshold of the instrument runway.
- **Straight In Approach.** If an arriving aircraft is making a complete instrument approach, departing traffic will not be permitted to take off in any direction within 5 minutes of the estimated time the instrument traffic will be over the threshold of the instrument runway. For take-offs in a direction within 45° of the reciprocal of the instrument runway, no take offs within 3 minutes of the estimated time the instrument traffic will be over the threshold of the instrument runway, or after the instrument aircraft has passed a designated fix on the approach track.

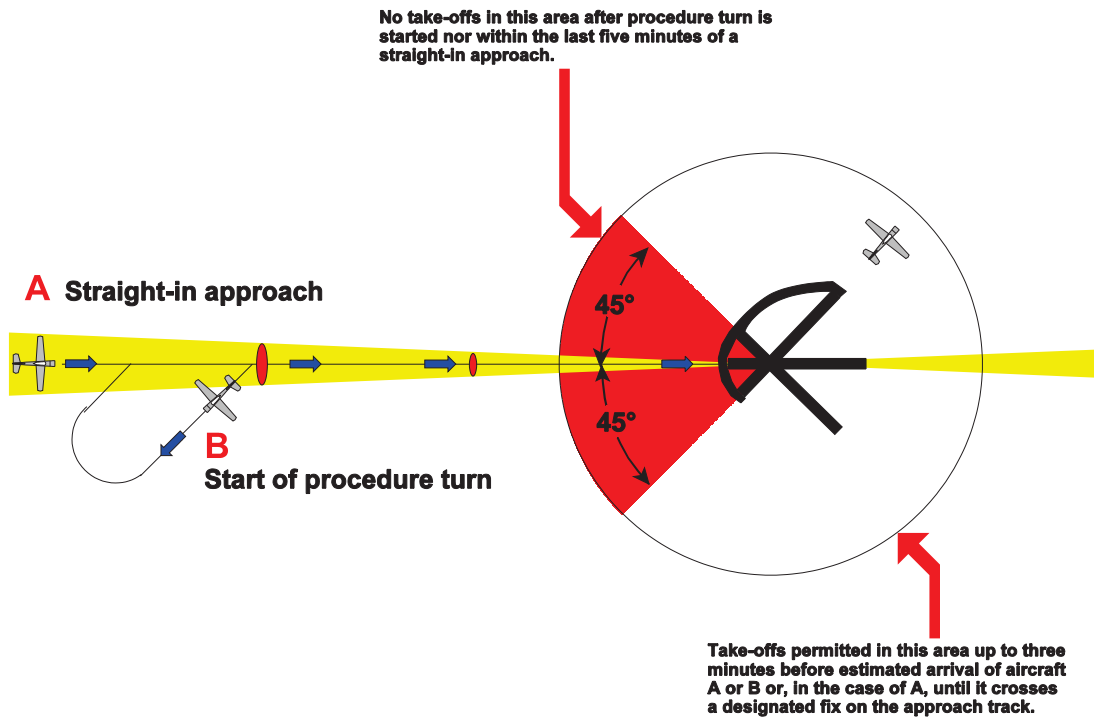

Figure 16.22:

16.50 Information to Arriving Aircraft. If a pilot requests it, or it is apparent to ATC that the pilot of an aircraft is not familiar with the procedures for an instrument approach, information will be passed to enable the approach to be flown. If the aircraft has been cleared for a straight in approach, only details of the final approach track need be passed.

16.51 Missed Approach Tracks. Where parallel runway segregated operations (the Heathrow case) are in progress, a missed approach to the landing runway creates a simultaneous departure situation where procedures for Mode 3 are not in force. To overcome the problems this creates, procedures are to be implemented to ensure that the missed approach track diverges from the normal departure track by at least 30°.

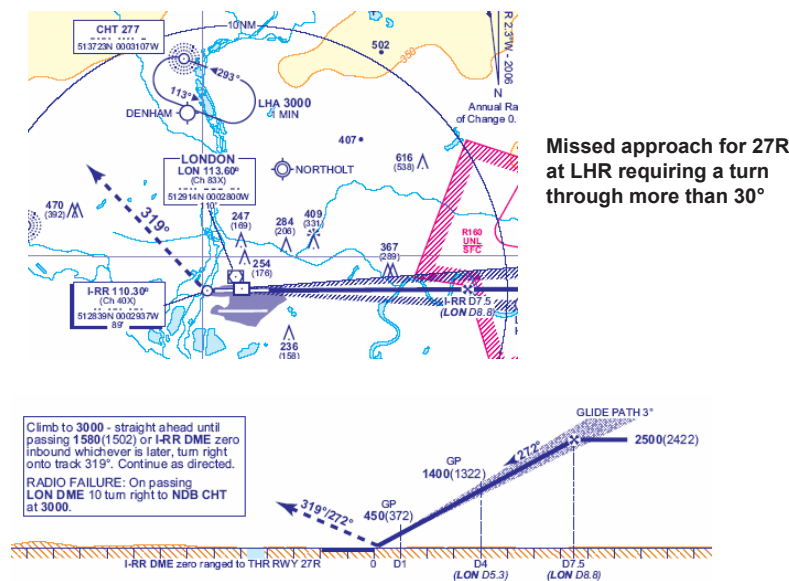

Figure 16.23:

STACKING

16.52 Approach Sequence. Where more than one aircraft is arriving it is normal for the aircraft at the lowest altitude to land first. Where necessary, a holding pattern will be established for 'stacking' of aircraft waiting to start the approach. Under certain circumstances, a later arrival will be given priority over earlier arrivals. Such circumstances are:

- Where an aircraft is compelled to land because of factors affecting the safety of the aeroplane or the occupants. In this case, the PIC of the aircraft involved will be expected to declare an emergency using either "MAYDAY" or "PAN PAN" procedures;
- Hospital aircraft or aircraft carrying sick or seriously injured people. International hospital flights will prefix initial RTF with "PAN PAN MEDICAL";
- Aircraft engaged in SAR operations;
- Other aircraft as may be determined by the authority.

16.53 Procedure. It is normal for 'stacks' to be established on the radio navigation beacons serving as the IAF for the instrument procedures to be used. The vertical size of the stack may be limited by airspace considerations and when full, 'overspill' stacks would be established on remote beacons. Arriving aircraft will be cleared into the stack at the lowest available level. Normal holding pattern joining procedures are used. Aircraft will be cleared to commence the instrument procedure from the lowest holding altitude (the bottom of the stack) using timed arrival procedures. If a pilot states his/her intention to continue holding awaiting a weather improvement when other pilots wish to make an instrument approach, the holding pilot will be instructed to take up another holding pattern or directed to rejoin the hold at the top. If a pilot elects to attempt an instrument approach when others remain in the hold, an unsuccessful approach would result in the aircraft being directed back into the stack at the top.

16.54 Expected Approach Time (EAT). When an aircraft enters a stack the controlling ATCO will pass an EAT which must be acknowledged by the pilot. This will be the time that the pilot can expect to commence the instrument approach. Initially the EAT will not be less than 30 minutes after the time of entry. If it is expected that the aircraft will not be held for more than 20 minutes the pilot will be informed "no delay expected". As the approach sequence progresses, if necessary the EAT will be revised by 5 minute intervals, passed to the pilot and acknowledged.

16.55 En Route Holding. It is often preferred to hold an aircraft en route at cruising altitude, rather than to progress the flight to the terminal stage and hold at low level with high fuel burn rates. Where delays are known to exist and aircraft are held en route, credit will be given for time spent holding en route by inserting the aircraft into the approach sequence ahead of other aircraft so that the aircraft that has held en route is not penalized.

STANDARD ARRIVAL CHART - INSTRUMENT (STAR) - ICAO

DISTANCES IN NAUTICAL MILES
BEARINGS, TRACKS AND RADIALS ARE MAGNETIC
ALTITUDES AND ELEVATIONS ARE IN FEET

LONDON HEATHROW via BIGGIN

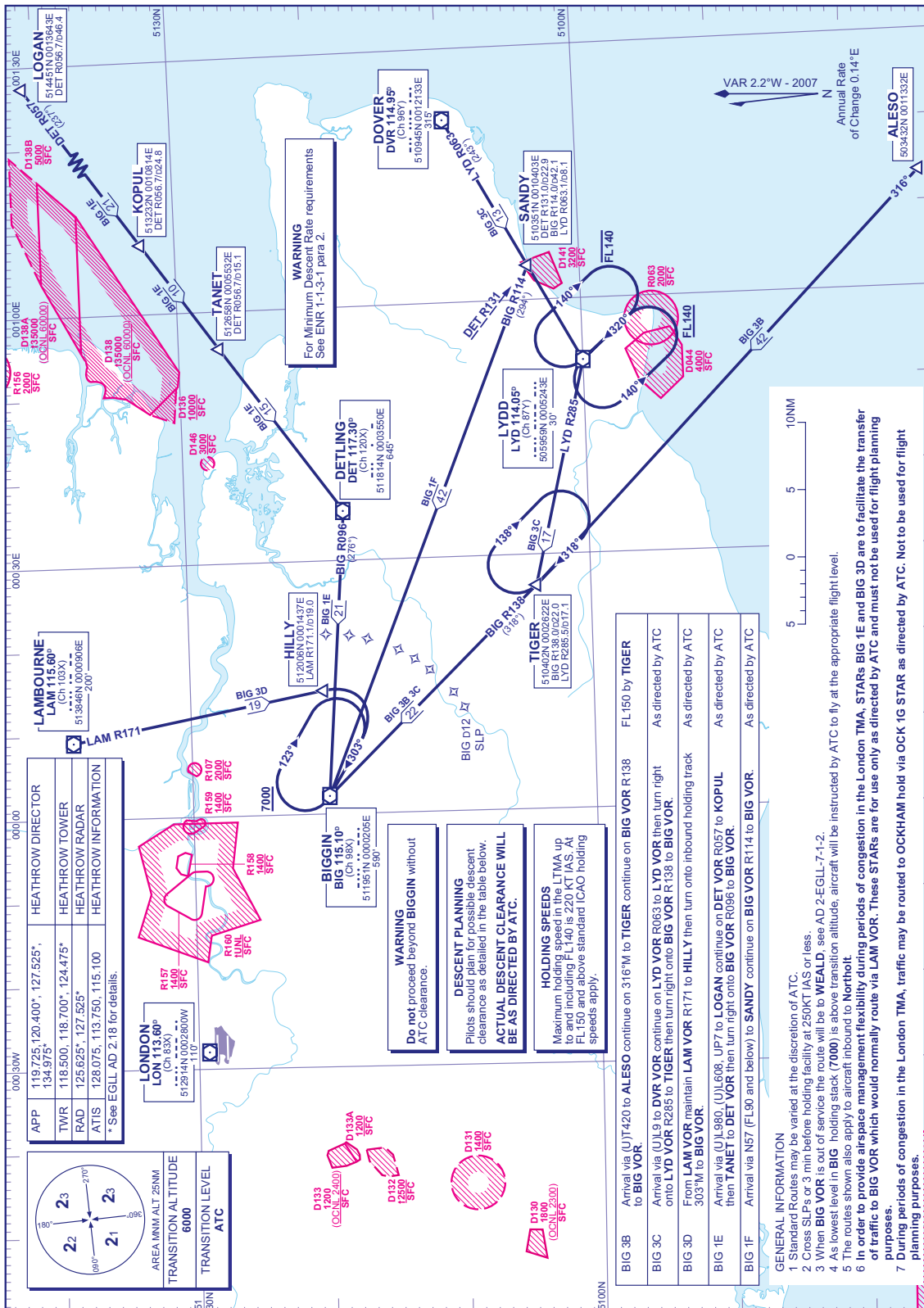

Figure 16.24: The STAR for LHR via the Biggin VOR showing the Biggin stack with LHA at 7,000 ft and the alternative stacks at LYDD.

QUESTIONS

1. What types of separation does ATC apply?
 - a. Horizontal, longitudinal and timing.
 - b. Horizontal, vertical and longitudinal.
 - c. Horizontal, vertical and composite.
 - d. Horizontal, vertical and lateral.

2. If you want to descend through the level of another aircraft on the same track, the basic separation is:
 - a. 20 minutes.
 - b. 10 minutes.
 - c. 5 minutes.
 - d. 15 minutes.

3. What is the minimum longitudinal separation standard required for RNAV routes?
 - a. 80 nm.
 - b. 60 nm.
 - c. 50 nm.
 - d. 20 nm.

4. What is the vertical separation minimum below 30,000 ft?
 - a. 500 ft.
 - b. 1,000 ft.
 - c. 2,000 ft.
 - d. It depends whether or not RVSM is applied.

5. What is the minimum vertical separation between IFR aircraft flying in the same direction above 30,000 ft in non RVSM airspace?
 - a. 1,000 ft.
 - b. 500 ft.
 - c. 2,000 ft.
 - d. 4,000 ft.

6. When can one aircraft pass through the level of another aircraft which is flying along an ATS route, in VMC maintaining own separation?
 - a. If the pilot requests and the state approves.
 - b. If the pilot requests and it is day time.
 - c. If the pilot requests during day or night.
 - d. Irrelevant - the manoeuvre is not permitted.

7. What is the separation based on RNAV when RNP is specified is:
 - a. 80 nm.
 - b. 50 nm.
 - c. 80 or 50 dependant upon the RNP type.
 - d. 15 minutes.

8. If two aircraft are using the same VOR for track separation, what distance must the aircraft be from the VOR before one of the two may commence a climb or descent?
- 5 nm.
 - 10 nm.
 - 15 nm.
 - 20 nm.
9. Whilst under IFR in VMC you decide to maintain your own separation to descend through the level of another aircraft. What is required?
- During day you must request clearance and with ATC authority approval.
 - You must request clearance and the ATC authority must approve, during day or night.
 - You only need to request approval for the manoeuvre.
 - In CAS the manoeuvre is illegal.
10. Two aircraft are on the same track at the same level and are using simultaneous DME fixes from the same on track DME station. What is the minimum longitudinal separation applied?
- 10 nm.
 - 5 nm.
 - 20 nm.
 - 15 nm.
11. What is the separation standard between aircraft at the same altitude when using DME to determine range from a beacon?
- 10 nm where the first aircraft speed is 40 kts faster than the second.
 - 10 nm where the first aircraft speed is 20 kts faster than the second.
 - 20 nm where the first aircraft speed is 40 kts faster than the second.
 - 20 nm where the first aircraft speed is 20 kts faster than the second.
12. Two aircraft are using the Mach number technique (both at same Mach number or first faster than second) for same track separation. If using an RNAV track what would be the standard separation in lieu of time?
- 80 nm.
 - 60 nm.
 - 50 nm.
 - 25 nm.
13. When can a controlled flight be given permission to climb/descend maintaining own separation in VMC?
- When directed by ATC.
 - When requested by the pilot and the ATC approves.
 - When there is no conflicting traffic.
 - When approved by the operator.
14. What is essential traffic?
- Flights engaged in priority flights i.e. VIP, hospital or police flights.
 - Any conflicting traffic.
 - Traffic which should be separated but which isn't.
 - Unidentified traffic on radar.

15. When is essential traffic information passed to an aircraft?
- Before a take-off clearance is issued.
 - Where traffic constitutes essential traffic to another controlled flight.
 - When the separation minima cannot be maintained.
 - When a pilot requests permission to descend or climb maintaining own separation.
16. What is the divergence angle that must be maintained from overhead an NDB to a range of 15nm to allow one aircraft to climb/descend through the level of another?
- 15°.
 - 30°.
 - 45°.
 - 60°.
17. The longitudinal separation minimum, based on time between two aircraft at the same altitude, for which navigation aids can give a frequent determination of position and speed and when the preceding aircraft has a true airspeed of at least 40 kts higher than the following aircraft, is:
- 5 minutes.
 - 6 minutes.
 - 10 minutes.
 - 3 minutes.
18. A separation minimum based on "RNAV" distance can be used at the moment the level is being passed, assuming that every aircraft reports its distance to or from the same "on-track" waypoint. The minimum is:
- 60 nms.
 - 80 nms.
 - 50 nms.
 - 20 nms.
19. With the Mach number technique applied what is the longitudinal standard separation between two aircraft of which the preceding aircraft is 0.04M faster than the following aircraft?
- 10 minutes.
 - 9 minutes.
 - 8 minutes.
 - 7 minutes.
20. What is the divergence angle that must be maintained from overhead a VOR to a range of 15nm to allow one aircraft to climb/descend through the level of another?
- 15°.
 - 30°.
 - 45°.
 - 60°.

21. The longitudinal separation minimum, based on time between two aircraft at the same altitude, for which navigation aids can give a frequent determination of position and speed and when both aircraft have updated navigation data, can be reduced to 5 minutes if:
- the first aircraft has updated the navigation data within the last 10 minutes.
 - both aircraft have updated the navigation data within the last 10 minutes.
 - the second aircraft is updating navigation data at the time.
 - the second aircraft has updated the navigation data within the last 10 minutes.
22. Two aircraft are on crossing tracks at the same level where the navigation aids do not permit frequent update of speed and position. What is the minimum separation applied?
- 3 minutes.
 - 5 minutes.
 - 10 minutes.
 - 15 minutes.
23. What is the required track divergence between the departure track and the missed approach track for parallel runway operations?
- 15°.
 - 30°.
 - 45°.
 - 60°.
24. Longitudinal separation based on time for aircraft at the same level when navigation aids permit frequent determination of speed and position and where the preceding aircraft is maintaining TAS 20 kts faster than the succeeding aircraft, is:
- 10 minutes.
 - 2 minutes.
 - 5 minutes.
 - 3 minutes.
25. The reduced radar separation provided to aircraft established on the same localiser course is:
- 2 nm.
 - 5 nm.
 - 3 nm.
 - 2.5 nm.
26. Longitudinal separation based on time for aircraft at the same level when navigation aids permit frequent determination of speed and position is:
- 10 minutes.
 - 2 minutes.
 - 5 minutes.
 - 3 minutes.

27. If an aircraft is making a 'straight in' approach a departing aircraft may take off in any direction:
- until 2 minutes before the arriving aircraft is estimated to be over the threshold of the instrument runway.
 - until 10 minutes before the arriving aircraft is estimated to be over the threshold of the instrument runway.
 - until 5 minutes before the arriving aircraft is estimated to be over the threshold of the instrument runway.
 - until 3 minutes before the arriving aircraft is estimated to be over the threshold of the instrument runway.
28. Unless otherwise prescribed by the appropriate ATS authority, the horizontal radar separation minimum is:
- 2.5 nm.
 - 5 nm.
 - 3 nm.
 - 2 nm.
29. Separation between departing aircraft may be reduced to 2 minutes when:
- the preceding aircraft is 30 kts or more faster than the succeeding aircraft.
 - the preceding aircraft is 20 kts or more faster than the succeeding aircraft.
 - the preceding aircraft is 10 kts or more faster than the succeeding aircraft.
 - the preceding aircraft is 40 kts or more faster than the succeeding aircraft.
30. To meet wake turbulence separation criteria for aircraft using timed approaches, what is the minimum applied to aircraft landing behind a heavy or medium aircraft?
- Medium behind heavy = 2 minutes.
 - Medium behind medium = 2 minutes.
 - Light behind medium = 4 minutes.
 - Medium behind heavy = 3 minutes.
31. Track separation between aircraft using the same DR fix shall be applied requiring the aircraft to fly:
- at least 45° separated at a distance of 15 nm or more from the fix.
 - at least 30° separated at a distance of 15 km or more from the fix.
 - at least 30° separated at a distance of 15 nm or more from the fix.
 - at least 45° separated at a distance of 15 km or more from the fix.
32. A separation minimum shall be applied between a light or medium aircraft and a heavy aircraft, and between a light and a medium aircraft, when the heavier aircraft is making a low or missed approach and the lighter aircraft is landing on the same runway in the opposite direction, or on a parallel opposite direction runway separated by:
- 730 m.
 - Less than 760 m.
 - 760 m.
 - Less than 730 m.

33. What would be the minimum distance applied in an approach sequence between a heavy aircraft followed by a light aircraft?
(*Note: It is assumed that this question is applicable to radar wake turbulence and assumes that the following aircraft is at the same level and the preceding aircraft.*)
- 6 nm.
 - 3 nm.
 - 4 nm.
 - 5 nm.
34. What is the minimum vertical separation between IFR aircraft flying below FL290?
- 500 ft.
 - 1,500 ft.
 - 2,000 ft.
 - 1,000 ft.
35. What is the minimum radar separation applied between aircraft on adjacent localiser courses during simultaneous parallel approaches mode 2 - dependant?
- 2 nm.
 - 2.5 nm.
 - 3 nm.
 - 5 nm.
36. When one aircraft will pass through the level of another aircraft on the same track where navigation aids permit frequent determination of speed and position, the minimum longitudinal separation provide is:
- 5 minutes at the time the level is crossed.
 - 10 minutes at the time the level is crossed.
 - 15 minutes at the time the level is crossed.
 - 20 minutes at the time the level is crossed.
37. In order to meet the wake turbulence separation criteria, what separation should be applied when a medium aircraft is taking off behind a heavy and both are using the same runway?
- 2 minutes.
 - 3 minutes.
 - 4 minutes.
 - 1 minute.
38. What is the reduced radar separation applied between aircraft on the same ILS localiser course within 10 nm of touchdown?
- 5 nm.
 - 2.5 nm.
 - 3 nm.
 - 2 nm.

39. Longitudinal separation based on time for aircraft at the same level when navigation aids permit frequent determination of speed and position and the preceding aircraft is maintaining a TAS 40kts faster than the succeeding aircraft is:
- 10 minutes.
 - 15 minutes.
 - 5 minutes.
 - 3 minutes.
40. RNAV distance based separation may be used at the time the level is crossed, provided that each aircraft reports its distance to or from the same 'on track' waypoint. The minimum is:
- 60 nm.
 - 50 nm.
 - 20 nm.
 - 80 nm.
41. The normal radar separation standard may be reduced, within 40 nm of the Radar head, to:
- 3 nm.
 - 5 nm.
 - 1.5 nm.
 - 1 nm.
42. What wake turbulence separation is applied when a light aircraft is taking off behind a medium aircraft?
- 3 minutes.
 - 1 minute.
 - 2 minutes.
 - 5 minutes.
43. One minute separation may be used between departing aircraft if the tracks to be flown diverge by at least:
- 25° immediately after take off.
 - 45° immediately after take off.
 - 30° immediately after take off.
 - 15° immediately after take off.
44. The separation method whereby the vertical and horizontal separation may be reduced to a minimum of half the standard is called:
- composite separation.
 - combined separation.
 - reduced separation.
 - essential separation.

45. The longitudinal separation minima based on distance using DME from 'on track' DME stations is:
- 10 nm.
 - 5 nm.
 - 20 nm when the leading aircraft maintains a TAS 20kts faster than the succeeding aircraft.
 - 20 nm.
46. The longitudinal separation minima based on distance using DME where each aircraft uses 'on track' DME stations is:
- 10 nm when the leading aircraft maintains a TAS 20kts faster than the succeeding aircraft.
 - 10 nm when the leading aircraft maintains a TAS 40kts faster than the succeeding aircraft.
 - 20 nm when the leading aircraft maintains a TAS 10kts faster than the succeeding aircraft.
 - 10 nm when the leading aircraft maintains a TAS 10kts faster than the succeeding aircraft.
47. Aircraft flying reciprocal tracks may be cleared to climb and descend through the level of the other aircraft provided the manoeuvre does not commence until:
- 5 minutes after the aircraft are assumed to have passed each other.
 - 10 minutes after the aircraft are assumed to have passed each other.
 - 15 minutes after the aircraft are assumed to have passed each other.
 - 20 minutes after the aircraft are assumed to have passed each other.
48. An aircraft will not be given clearance to take off until the preceding aircraft has:
- reported airborne and climbed to 500 ft.
 - left the aerodrome traffic zone.
 - crossed the upwind end of the runway or made a turn away from the runway.
 - reported 'downwind'.
49. A departing aircraft will not be permitted to take off when arriving instrument traffic has:
- started the procedure turn.
 - passed a point 10 minutes from the threshold of the instrument runway.
 - reported "field in sight".
 - reported "long final".
50. Wake turbulence separation is:
- applicable at all times.
 - applicable only between aircraft of different wake turbulence categories.
 - applicable only between aircraft at the same level or where the succeeding aircraft is less than 1,000 ft below the preceding aircraft.
 - not applicable to parallel runway operations.

ANSWERS

Question	Answer	Reference	Question	Answer	Reference
1.	C	16.1	26.	A	16.23
2.	D	16.24	27.	C	16.49
3.	A	16.29	28.	B	16.32
4.	B	16.5	29.	D	16.45
5.	D	16.5	30.	A	16.37
6.	B	16.14	31.	A	16.17
7.	C	16.30	32.	B	16.40
8.	C	16.17	33.	A	16.42
9.	A	16.14	34.	D	16.5
10.	C	16.26	35.	A	16.33
11.	B	16.26	36.	B	16.24
12.	A	16.30	37.	A	16.38
13.	B	16.13	38.	C	16.33
14.	C	16.4	39.	D	16.23
15.	B	16.4	40.	D	16.29
16.	B	16.17	41.	A	16.33
17.	D	16.23	42.	C	16.37
18.	B	16.29	43.	B	16.45
19.	D	16.28	44.	A	16.3
20.	A	16.17	45.	D	16.26
21.	D	16.23	46.	A	16.26
22.	D	16.23	47.	B	16.24
23.	B	16.51	48.	C	16.45
24.	C	16.23	49.	A	16.49
25.	D	16.33	50.	C	16.34

CHAPTER SEVENTEEN
CONTROL OF AIRCRAFT

Contents

PROCEDURAL ATC	299
RADAR CONTROL	299
RADAR IDENTIFICATION	301
RADAR SERVICE	301
AERODROME CONTROL	305
APPROACH CONTROL SERVICE	307
AIR TRAFFIC ADVISORY SERVICE	313
AIRCRAFT EMERGENCIES	313
QUESTIONS	316
ANSWERS	322

PROCEDURAL ATC

17.1 Concept. The provision of ATC to air traffic is largely a post WW2 concept. The need for ATC was highlighted by the high loss rate of aeroplanes during WW2 on and in the vicinity of aerodromes due to mid air collisions, collisions with obstacles and inadvertent flight into terrain. This led to the establishment of ATC at aerodromes provided by the control tower but beyond the aerodrome boundary (now replaced by the ATZ) little was provided other than a 'flight following' monitoring service essentially to ascertain that the aircraft was still airborne! After an accident in the US involving two Constellations over the Grand Canyon in the early 1950s concern was expressed that two relatively small objects flying over a vast geographic area could be a threat to each other. This led to the establishment of a 'one-way' system for east/west flight over the continental US and gave rise to the first established 'procedural' ATC service. The service provided separation by requiring aircraft naturally cruising at the same altitude to route via different routes (lateral geographic separation). It required the pilot to tell the air traffic controller where the aircraft was by passing position reports. The data collected was plotted and as the flight progressed any apparent collision risk was determined and the flights concerned would be asked to alter course to eliminate the problem. The problems with this were that the equipment used to determine the aircraft position was, by modern standards, somewhat crude; the communications equipment and facilities were poor and the availability of flight information including met data was virtually non-existent. However, the density of air traffic was also low and the application of large 'buffer' distances overcame the problems of inaccuracy and poor communications.

17.2 Flight Strips. Within the ATC centres, the progress of a flight is tracked with a paper system known as a flight strip. The strip is originated from the ATS FPL and in theory, is transferred from ATCO to ATCO and from centre to centre. Clearly, the progress of the flight strips may not actually be 'physical' but will require a new strip to be compiled at centre 'B' from information passed by telephone from centre 'A'. Within a centre the progress may be a physical passing of the strip from one controller to another. This system is virtually fool-proof and over the last 20 years ATC research centres (i.e. Eurocontrol at Brétigny) have tried to come up with electronic replacements. All attempts have failed and the paper flight strip is still the means by which procedural ATC is implemented.

17.3 Procedural Separation. The procedural separation standards are covered in chapter 16 of these notes.

17.4 Communications. Ever since aircraft have been able to carry radios, they have been used for air to ground communications. The present day ATC system relies on VHF two-way communications to make the system work. Over the ocean areas and remote land areas, HF is used together with the ability to maintain a radio watch using the Selcal system which relieves the pilot of having to actually listen to the radio. Each ATC unit has a radio callsign i.e. Oxford Approach as does each aircraft. If two aircraft have the same or confusingly similar call signs, ATC can ask one aircraft to use another call sign for the time being.

RADAR CONTROL

17.5 Concept. The primary use of Radar in ATC is to enhance the provision of separation. In theory, radar gives the ATCO the ability to determine the aircraft position with more accuracy than the pilot can! However, SATNAV systems with precision accuracy (+/- 30cm) are now adding a whole new dimension to ATC. Radar systems cover long range surveillance used in area control (en route traffic), terminal aerodrome radar (TAR) used in the vicinity of an aerodrome or aerodromes to provide a service to arriving and departing traffic, and surface movement radar at an aerodrome to provide the aerodrome controller with information in poor visibility or at night.

The system that provides a radar return displayed on a display system is called Primary Surveillance Radar (PSR). All radar systems can be augmented with Secondary Surveillance Radar (SSR) to provide flight specific identification and altitude information. Radar can also be used in the provision of precision or non-precision approaches.



Figure 17.1: ATC radar head at Cleve Hill, Shropshire.



Figure 17.2: ATC radar head at London Heathrow.

17.6 Radar Services. At its most basic, radar is used to derive information for the updating of information displayed on the flight strips. In this manner, it is augmenting a procedural system. If however, the radar response from a specific aircraft can be individually determined (identified) then the provision of separation from other radar contacts (aircraft) can be achieved. In this manner, the radar derived information is used directly to provide separation to a much greater degree of accuracy. The types of radar service are:

- Radar Control for controlled en-route aircraft
- Approach Radar Control for arriving and departing controlled traffic
- Radar vectoring: the provision of navigation instructions to an aircraft to achieve a specific aim i.e. positioning to intercept the ILS localiser.
- PAR and SRA as instrument approach systems

As with all ATC procedures, a radar service is only provided inside CAS. ICAO does however permit the use of radar to obtain information to enable the provision of a FIS outside of CAS. Radar may also be used to assist the provision of information as part of the Advisory ATC service provided in class F airspace. At an aerodrome, radar may be used by the aerodrome controller to determine the separation between departing aircraft but not to actually apply the separation. The UK NATS radar services RAS and RIS are not ICAO procedures and are not covered in the LOs for Air Law and ATC.

17.7 Radar Separation. There is only one radar separation standard and this is 5nm. As defined in chapter 16, reduced radar separation may be applied under specific conditions. The separation applied is based upon the aircraft position derived from PSR only. As defined and specified in Chapter 16, wake turbulence separation can be applied using radar derived information. In this case the separation standards applied are based on distance.

RADAR IDENTIFICATION

17.8 Requirement. Before a radar controller can provide any service to an aircraft, the radar identity of the aircraft must be established. Clearly, the basic SSR capability is to identify a specific aircraft squawking a specifically allocated code, therefore this method of identification is most commonly used. It is also the quickest method of identification. Once an aircraft has been allocated a SSR code, it must be retained until otherwise advised by the radar controller. If an emergency situation arises, the pilot should not squawk A7700 if the identity of the aircraft has already been established using SSR. All other methods of identification by radar require the ATCO to observe the radar contacts on the display screen and determine, either from geographic position or from a specific manoeuvre, which contact is the aircraft requiring the service. Such observations include:

- Geographic location i.e. '2nm west of Woodstock'
- Relative to a radio navigation aid - "On the 230 radial from the Daventry VOR DME 5 nm"
- Latitude and longitude
- Georef position
- Turn through 30° or more away from desired course and then return to the course
- Positive handover from a radar controller who had previously identified the aircraft

17.9 Procedure. When identifying a radar contact as a specific aircraft, the radar controller must tell the pilot how the identification was achieved. The controller will use the phrase '**radar contact**' to indicate that aircraft has been identified and that until further advised, a service will be provided - "G-CD radar contact 2nm west of Oxford". This position should agree with the position the pilot thinks the aircraft is at. If significantly different the pilot must inform the controller in the event that the controller has mis-identified the aircraft.

RADAR SERVICE

17.10 Commencement. After identification, the pilot is to be told what type of radar service is to be provided and what the objective is - "G-CD radar contact 6 nm west of Compton, radar control, expect radar vectors for ILS approach runway 26"

17.11 Termination. When an aircraft reaches the limit of radar cover, the edge of a radar vectoring area or the aim of the service has been achieved, the pilot will be advised that the service is terminated, given position information and instructions/advice how to continue. For instance: "G-CD radar service terminated, presently 10nm south of Benson, resume own navigation, suggest continue with London Information 125.650"

17.12 Radar Vectoring. Radar vectoring is the passing of navigation information to a pilot by a radar controller to achieve the aircraft flying a required track. This may be simply to avoid weather or manoeuvre around another aircraft radar contact. Once the aim of the vectoring has been achieved, the pilot will be told to “Resume own navigation”. This implies that the radar vectoring has ended. It may be provided to position the aircraft such that a straight in instrument approach can be achieved. In any event, radar vectoring is only carried out inside a radar vectoring area (RVA).

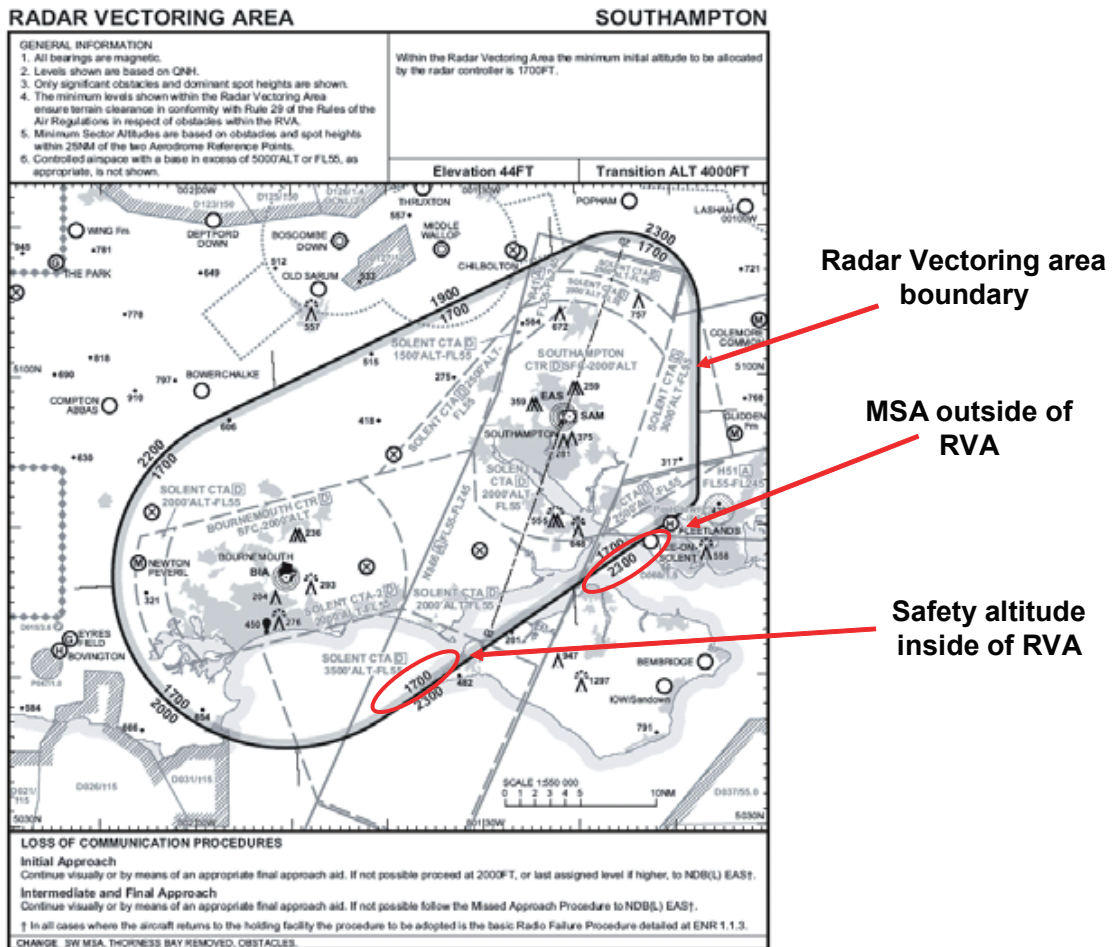

Figure 17.3: Radar vectoring area.

17.13 Vectoring Procedure. Radar vectoring will not begin until the aircraft radar contact is determined to be within the RVA. The RVA will be displayed on the radar display in the form of a video map electronically generated within the radar display software. Because of possible inaccuracies (‘slippage’) aircraft will not be radar vectored closer to the edge of the RVA than half the applicable radar separation standard or 2.5nm whichever is greater. Normally, radar vectoring will begin at a fix at MSA. It may however, begin at any time after the aircraft has been identified on radar and the aircraft altitude is known to the ATCO. The RVA chart displays the obstacles in the area together with the elevation of the terrain. The radar controller will pass magnetic headings to the pilot to steer to make good a desired track over the ground. The pilot will fly the heading and the controller will adjust the heading for the wind. The aircraft will not be given clearance to descend below the RVA safe altitude (highest obstacle in RVA plus MOC rounded up) until established on the ILS localiser course or on the final approach track, or the pilot reports that he/she is continuing the approach visually. Throughout the procedure, the radar controller must be aware of the elevation of the terrain and the aircraft configuration to avoid spurious GPWS warnings.

17.14 ILS Vectoring Requirements. Where the purpose of vectoring is to position the aircraft at a point where localiser capture is achieved, the closing heading to the centreline of the ILS localiser is 45° . If parallel runway operations Modes 1 or 2 are in use, the angle is limited to 30° . The closing heading is to be maintained for a distance of not less than 1nm.

17.15 Radar Controlled Approach. Radar may be used to provide a precision (PAR) or non precision (SRA) approach to a runway. In both cases, the radar controller provides radar derived information to the pilot to permit the aircraft to be flown along a pre-defined track and, in the case of PAR, a defined glide path. For SRA, a recommended vertical profile (virtual glide path) is published. If radar contact is lost for any significant period during the last 2 nm of a radar approach, the pilot will be advised to carry out a missed approach procedure.

17.16 PAR. This is specifically engineered radar equipment that provides very accurate (precision) azimuth and glide path information to a dedicated radar controller. Whilst providing a PAR service, the controller will be engaged in providing the service to one aircraft and will not have any other duty. The pilot will be passed azimuth (right or left turn or heading) information and elevation ('on'; 'above'; or 'below') information to fly the aircraft along the predetermined flight path. The service will continue until the aircraft reaches DH which would have been passed by the pilot to ATCO at the beginning of the procedure. At DH the pilot will be informed that the aircraft is at DH and radar service is terminated. Because the information is passed in the form of a continuous talk-down, the pilot must stay on the PAR approach frequency. The radar controller is therefore responsible for obtaining a landing clearance from the aerodrome controller. Normally this would be done at 4nm from the threshold of the landing runway, but may be delayed by the aerodrome controller until 2nm. If no clearance has been received at 2nm, the pilot will automatically begin the missed approach procedure. At some time during the approach (usually at 3nm) the pilot will be asked to confirm a final check of the landing gear (and at a military aerodrome, the flap configuration). At some point during the approach, the flight crew will cross check the position of the aircraft against the PAR information (for instance using DME and rad alt information). PAR will not generally be found at civilian aerodromes; however, the new generation of PAR equipment is widely installed at military aerodromes.



Figure 17.4: PAR installation at RAF Marham.

17.17 SRA. An SRA approach is a non precision procedure using TAR and will therefore have a determined MDA/H. The procedure for SRA is similar to PAR except that in this case advisory height information is passed with range information i.e. “5 miles from touchdown, you should be passing one thousand five hundred and fifty feet”. SRA approaches always have an RTR figure stated. This is the range at which the radar service will be automatically terminated. RTR stands for Radar Termination Range. Typically RTR2 is used indicating that the radar service will be terminated at 2nm from the threshold of the landing runway. During the procedure, the pilot is passed magnetic headings to fly and corrections (left or right) to the extended centreline of the landing runway. If the RTR is 2, distance information is passed (with advisory height information) every 1 nm. If RTR1 is applicable, range and height information is passed every 0.5nm. As for PAR, the radar controller will be responsible for obtaining a landing clearance from the aerodrome controller and passing it to the pilot. The approach plate for the SRA approach to Gatwick is shown below.

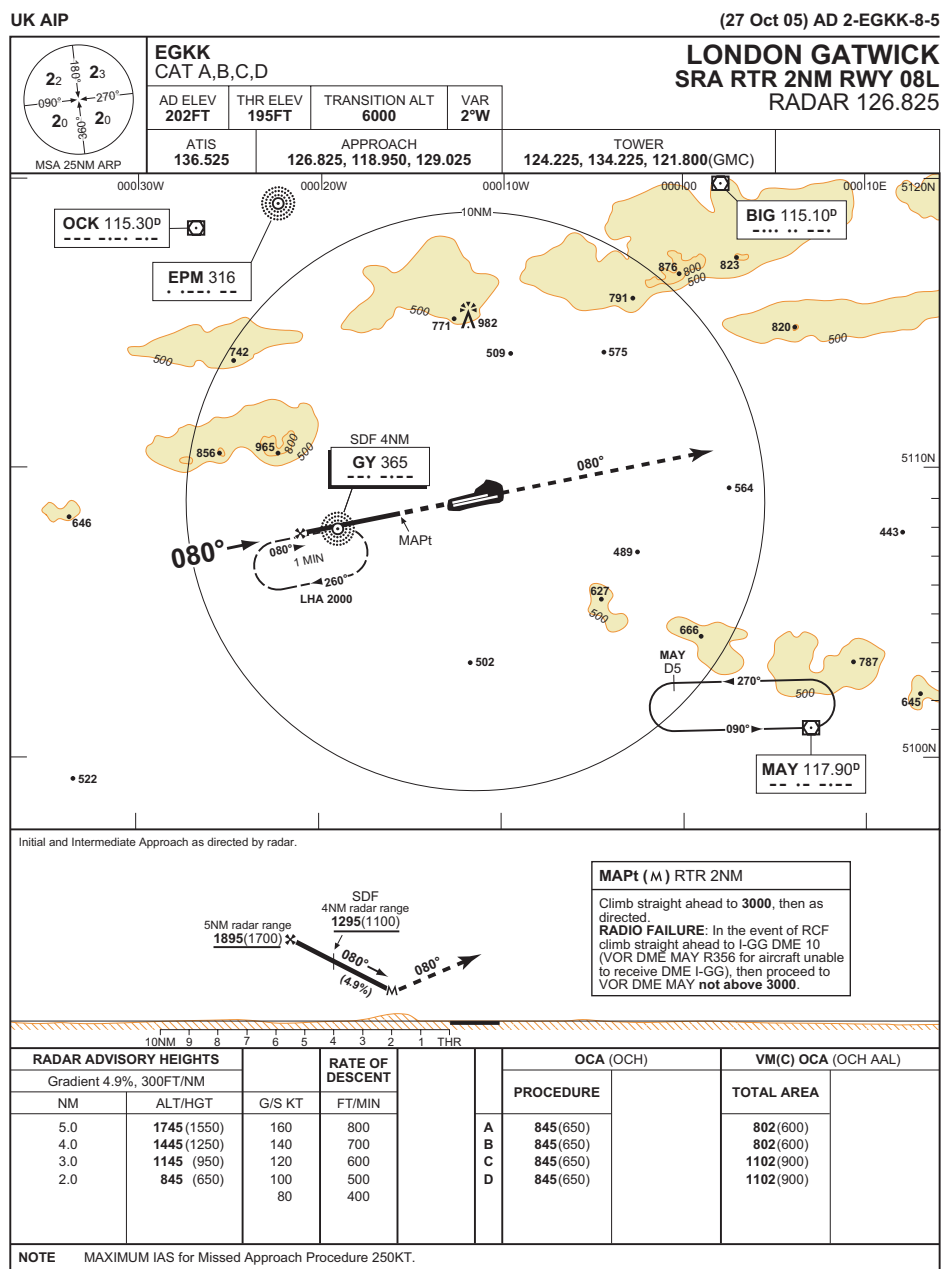

Figure 17.5: SAR approach.

AERODROME CONTROL

17.18 Introduction. The responsibility for avoiding collisions involving aircraft, obstacles, vehicles and personnel on or in the air in the vicinity of an aerodrome rests with the aerodrome controller. At a 'controlled aerodrome' (see definition) the aerodrome controller usually operates from the visual control room (VCR) situated at the top of the control tower. The VCR normally allows the aerodrome controller to see all parts of the aerodrome but may also have electronic aids to assist the controller when visibility is poor or at night. The primary duty of the aerodrome controller is to control access to the runway in use. The nature of the service offered is procedural, with the pilot telling the aerodrome controller where the aircraft is and the controller basing any instructions or clearances on that information. For departing aircraft the aerodrome controller will give a take-off clearance which will be de-facto permission to enter and take-off from the runway. Once airborne the pilot will report 'airborne' at which time another aircraft can be cleared to use the runway.

17.19 Use of the Runway. The aerodrome controller will normally decide which runway will be used for take-off and landing operations. The 'runway-in-use' will determine the direction for instrument approaches and the direction for the visual circuit. Normally, the wind direction will be the deciding factor, however, in calm or light wind conditions; another direction may be preferable for ATC, airspace restriction or noise abatement requirements. At London Heathrow, a departing aircraft will be expected to accept a 5kt tail wind and use the noise preferential runways. It is a generally accepted practice that only one aircraft is permitted on the runway at any time.

17.20 Departing Aircraft. Aircraft waiting for take-off will be held at a runway holding point on the taxiway at a safe distance from the centreline of the runway. It is normal procedure for aircraft to be given a 'take-off immediate' clearance. This requires the pilot to taxi the aircraft on to the runway and without stopping, line the aircraft on the centreline and then apply the necessary power to commence the take off run. A succeeding aircraft may be permitted to enter the runway (given the instruction 'line up and hold') as soon as the preceding aircraft has commenced the take off run. A succeeding aircraft will not be given clearance to take off until the preceding aircraft has either crossed the upwind threshold, or has commenced a turn away from the runway direction.

17.21 Arriving Aircraft. When established on final approach, an arriving aircraft will be given clearance to land if the runway is available. For an arriving instrument approach, the clearance to land will normally be given at about 4nm from the threshold and certainly no later than 2nm from the threshold. If the pilot of an arriving instrument approach has not been given a landing clearance, the missed approach procedure is to be flown commencing at 2nm. Once the landing run is complete and the pilot has turned the aircraft onto the taxiway, he/she is required to make a report to the aerodrome controller to confirm that the aircraft has 'vacated the runway'. This is to be made when all of the aircraft has passed the appropriate holding point.

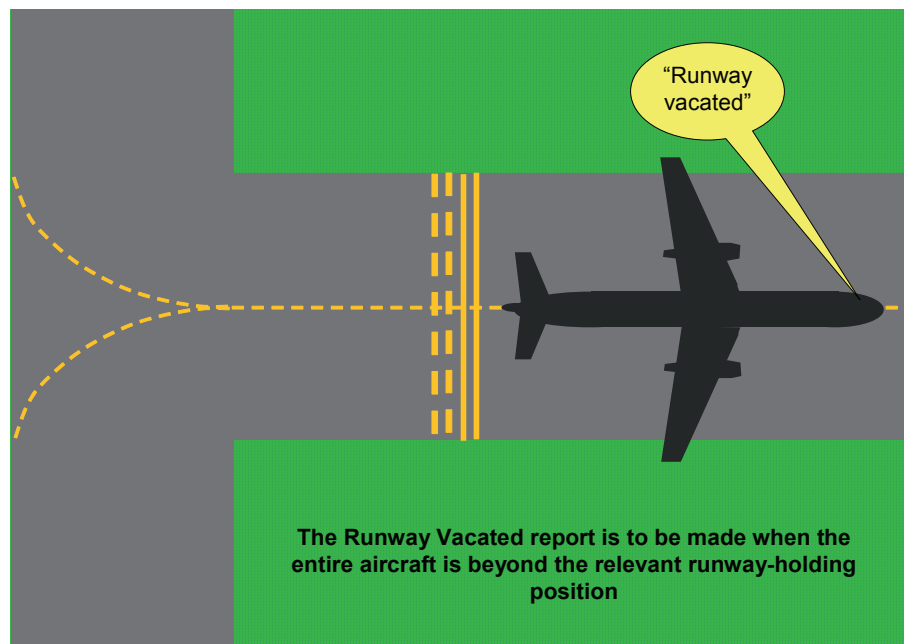

Figure 17.6: Runway vacated report.

17.22 “Land After” Clearance. Under certain conditions, a pilot may be given a provisional clearance to “land after the preceding aircraft”. This will be done to increase the utilisation of the runway at peak times so that aircraft may arrive at 1 minute intervals. In this case, the pilot of the second aircraft will decide if the preceding aircraft will be clear of the runway at the time he/she lands and that there is sufficient separation between the aircraft throughout the manoeuvre. Throughout the landing, the pilot of the following aircraft must be able to see the previous aircraft and is responsible for maintaining separation. In this case, the pilot of the following aircraft will apply the appropriate visual separation which may be less than the procedural separation. The provision of ‘fast turn off lanes’ or ‘rapid exit taxiways’ on aerodromes enhances this option. The necessary conditions are:

- Only permitted during daylight
- The pilot of the second aircraft must be able to see the preceding aircraft throughout the manoeuvre;
- The runway must be dry (braking action good);
- The pilot and operator of the aircraft concerned must be aware that the runway occupancy time is limited to 50 seconds;
- The ATCO must be able to see the entire length of the landing runway.

17.23 Flight Information. As with all other ATSU's the aerodrome controller is responsible for the provision of flight information to aircraft on the aerodrome or in flight in the vicinity of the aerodrome. Routine information may be passed using ATIS but the aerodrome controller is responsible for making sure that departing aircraft and arriving aircraft at the initial contact with ‘tower’ are aware of any limitations to the radio navigation or visual aids on the aerodrome. Likewise any work in progress on the aerodrome is to be reported in a timely manner.

17.24 Information to Departing and Arriving Aircraft. The aerodrome controller is required to ensure that pilots have adequate and accurate aerodrome information prior to using the aerodrome. Where wind information is passed the direction is to be in degrees magnetic so that the pilot can relate this directly to the aircraft compass.

- **Prior to Taxi.** Before taxiing a pilot is to be told:
 - What runway is in use;
 - The surface wind direction and speed;
 - The aerodrome QNH;
 - The air temperature for the runway to be used (for turbine engine aircraft only);
 - The visibility in the direction of take-off or the RVR;
 - The correct time.

- **Prior to Take Off.** The following is passed to a pilot prior to take-off:
 - Any significant changes in wind conditions, air temperature, visibility or RVR
 - Significant meteorological conditions in the take off and climb out areas (unless the pilot has already been informed)

- **Prior to Entering the Traffic Pattern.** Before entering the traffic pattern or commencing an approach to land, a pilot is to be provided with the following information:
 - The runway to be used;
 - The surface wind direction and speed;
 - The aerodrome QNH;

17.25 Alerting Service. The aerodrome controller is responsible for the activation of the aerodrome crash rescue and firefighting service when required. If necessary, all visual circuit traffic can be suspended by the aerodrome controller for the duration of an emergency situation. The aerodrome controller may suspend the visual circuit on the instructions of the Area Control Centre if an aircraft in an emergency is likely to land at the aerodrome. If an aircraft which has been cleared to land fails to do so within 5 minutes after the landing clearance has been issued, or fails to contact the aerodrome controller after having been transferred, the aerodrome controller will report the fact immediately to the ACC or the FIC and the Alert Phase will be declared immediately.

APPROACH CONTROL SERVICE

17.26 Establishment. Approach control provides ATC to traffic departing from, and arriving at, aerodromes. Where IFR traffic is departing to join airways, the approach controller is the link between the aerodrome departure procedures and the airways joining procedures and vice versa for arriving traffic. It usual nowadays for radar to be used in approach control although procedural approach control exists (as here at Oxford for the VDF and NDB approach procedures). Where an aerodrome is in a CTR, approach control is mandatory and the controller may be known as the zone controller. The approach office (approach control room) may be at another aerodrome if there is more than one aerodrome in the CTR. Where an aerodrome is outside of a CTR, approach control (where established, as here at Oxford) is advisory. Where procedures are established for instrument approaches, the approach controller may delegate radar vectoring (and monitoring of self positioning) to a radar director. At aerodromes in CTRs where the met conditions are IMC or the criteria for VMC take-off cannot be met, the approach controller will be responsible giving clearance for take-offs. It will also be the approach controller's responsibility for obtaining clearance to land from the aerodrome controller for IFR flights carrying out low visibility instrument approaches.

17.27 Departing Aircraft. When the control of traffic is based on an air traffic control clearances, the clearance is to specify:

- Direction of take-off and turn after take-off,
- Track to be made good before proceeding on desired heading,
- Level to maintain before continuing climb to assigned cruising level,
- Time, point and/or rate at which level change shall be made,
- Any other necessary manoeuvre consistent with the safe operation of the aircraft.

17.28 Take off direction. Departing aircraft may be expedited by suggesting a take-off direction which is not into the wind. It is the responsibility of the pilot-in-command of an aircraft to decide between making such a take-off, and waiting for normal take-off in a preferred direction.

17.29 Delays. In order to avoid excessive holding at the destination, aircraft may be held at the departure aerodrome prior to take off. ATC is required to advise operators (or their nominated representative) of substantial delays and in any case where the delay is expected to exceed 30 minutes.

17.30 Information for departing aircraft. The following information is to be passed to departing aircraft by the approach controller:

- **Meteorological information.** Information regarding significant changes in the meteorological conditions in the take-off or climb-out area, obtained by the unit providing approach control service is to be transmitted to departing aircraft without delay, except when it is known that the aircraft already has received the information. Significant changes in this context include those relating to surface wind direction or speed, visibility, runway visual range, or air temperature (for turbine engined aircraft), and the occurrence of thunderstorm or cumulonimbus, moderate or severe turbulence, windshear, hail, moderate or severe icing, severe squall line, freezing precipitation, severe mountain waves, sand storm, dust storm, blowing snow, tornado or waterspout.
- **Visual or non-visual aids.** Information regarding changes in the operational status of visual or non-visual aids essential for take-off and climb shall be transmitted without delay to a departing aircraft, except when it is known that the aircraft already has received the information.
- **Essential traffic information.** Information regarding essential local traffic known to the controller shall be transmitted to departing aircraft without delay.

17.31 Arriving Aircraft. Arriving aircraft (aircraft being handed over to approach from area (airways)) may be required to report when leaving or passing a reporting point, or when starting procedure turn or base turn, or to provide other information required by the controller to expedite departing aircraft.

17.32 Initial approach clearance. An IFR flight will not be cleared for an initial approach below the appropriate minimum altitude unless:

- The pilot has reported passing an appropriate point defined by a radio navigation aid; or
- The pilot reports that the aerodrome is (and can be maintained) in sight; or

- The aircraft is conducting a visual approach; or
- The aircraft's position has been positively determined by radar.

17.33 Visual Approach. Visual approach is defined as an approach by an IFR flight when either part or all of an instrument approach procedure is not completed and the approach is executed with visual reference to terrain. An IFR flight may be cleared to execute a visual approach provided that the pilot can maintain visual reference to the terrain and the reported ceiling is at or above the approved initial approach level for the aircraft so cleared; or the pilot reports at the initial approach level or at any time during the instrument approach procedure that the meteorological conditions are such that with reasonable assurance a visual approach and landing can be completed.

17.34 Separation. Separation shall be provided between an aircraft cleared to execute a visual approach and other arriving and departing aircraft. For successive visual approaches, radar or non-radar separation shall be maintained until the pilot of a succeeding aircraft reports having the preceding aircraft in sight. The aircraft shall be instructed to follow and maintain separation from the preceding aircraft. Transfer of communications should be effected at such a point or time that clearance to land or alternative instructions can be issued to the aircraft in a timely manner.

17.35 Instrument Approach. Instrument approaches are carried out under the supervision of the approach controller. Where radar vectoring and monitoring of approaches is carried out, control may be delegated to a radar director or radar final controller.

- **Speed control.** The method of maintaining separation during sequenced instrument approaches using radar is by asking the aircraft concerned to fly at specified a speed. It is usual for an aircraft to start an instrument approach (from the IAF) at 210kts (IAS).
For example a clearance might be: "Speedbird 289 leave Ockham heading 290 speed 210kts". This is a speed that most commercial operations aircraft can achieve without having to use drag or lift enhancing devices. If necessary the speed of a subsequent aircraft will be reduced to maintain the necessary time/distance interval between the aircraft. Speed adjustments will be made in intervals of no more than 20kts and required speeds will always be in multiples of 10 i.e. "Speedbird 289 maintain 180kts". During the latter stages of an approach, the pilot will need to reduce the speed to Vat so no further speed control will be applied after the aircraft has passed 4nm from touchdown.
- **Unfamiliar procedures.** If a pilot-in-command reports (or if it is clearly apparent to the ATC unit) that he or she is not familiar with an instrument approach procedure, the initial approach level, the point (in minutes from the appropriate reporting point) at which procedure turn will be started, the level at which the procedure turn shall be carried out and the final approach track shall be specified, except that only the last-mentioned need be specified if the aircraft is to be cleared for a straight in approach. The missed approach procedure shall be specified when deemed necessary.
- **Visual reference to terrain.** If visual reference to terrain is established before completion of the approach procedure, the entire procedure must nevertheless be executed unless the aircraft requests and is cleared for a visual approach.
- **Choice of procedure.** A particular approach procedure may be specified to expedite traffic. The omission of a specified approach procedure will indicate that any authorised approach may be used at the discretion of the pilot.

17.36 Holding. Where holding is required as part of an arrival procedure leading to an instrument approach, the approach controller will control the holding procedure (stack). Control may be delegated to a radar controller (director). Holding and holding pattern entry shall be accomplished in accordance with procedures established by the appropriate ATS authority and published in Aeronautical Information Publications. If entry and holding procedures have not been published or if the procedure are not known to the pilot in command of an aircraft, the appropriate air traffic control unit shall describe the procedures to be followed.

- **Holding point.** Aircraft shall be held at a designated holding point. The required minimum vertical, lateral or longitudinal separation from other aircraft, according to the system in use at that holding point, shall be provided.
- **Separation.** When aircraft are being held in flight, the appropriate vertical separation minima shall continue to be provided between holding aircraft and en-route aircraft while such en-route aircraft are within five minutes flying time of the holding area, unless lateral separation exists.
- **Holding levels.** Levels at holding points shall be assigned in a manner that will facilitate clearing each aircraft to approach in its proper priority. Normally the first aircraft to arrive over a holding point should be at the lowest level, with following aircraft at successively higher levels. However, aircraft particularly sensitive to high fuel consumption at low levels, such as supersonic aircraft, should be permitted to hold at higher levels than their order in the approach sequence, whenever the availability of discrete descent paths and/or radar makes it possible, subsequently, to clear the aircraft for descent through the levels occupied by other aircraft.
- **Alternate procedures.** If a pilot-in-command of an aircraft advises of an inability to comply with the approach control holding or communication procedures, the alternative procedure(s) requested by the pilot in command should be approved if known traffic conditions permit.

17.37 Stacking (Approach Sequence). Whenever approaches are in progress, the following procedures (stacking) are applied:

- **Priority.** The approach sequence (the stack) is established to permit the arrival of the maximum number of aircraft with the least average delay. Special priority **may** be given to:
 - An aircraft which anticipates being compelled to land because of factors affecting the safe operation of the aircraft (engine failure, fuel shortage, etc.).
 - Hospital aircraft or aircraft carrying any sick or seriously injured person requiring urgent medical attention.
- **Procedural sequence.** Except where timed approaches are in progress (see paragraph 17.38), succeeding aircraft will be cleared for approach (to start the procedure - leave the stack) when the preceding aircraft:
 - Has reported that it is able to complete its approach without encountering IMC; or
 - Is in communication with and has been sighted by the aerodrome controller, and reasonable assurance exists that a normal landing can be made.

- **Holding.** ATC will approve a request to hold for weather improvement (or for other reasons). If other aircraft holding decide to make an approach and radar is available, a pilot deciding to remain holding will be vectored to an adjacent fix to continue holding. Alternatively, he/she may be vectored (or given a procedural clearance) to place the aircraft at the top of the stack so that other aircraft may be permitted to carry out the procedure and land.
- **Credit time.** Where an aircraft has been authorised to absorb delay time whilst en-route (by reduced cruising speed or en-route holding), the time delayed should be credited in any stacking.

17.38 Timed Approaches. Timed approaches allow subsequent aircraft to commence approaches more frequently than as specified in paragraph 17.37. In this case an aircraft would be cleared to depart the fix of the stack a period of time after the preceding aircraft. The procedure must be authorised by the authority and the following complied with:

- A suitable point on the approach path (capable of being determined by the pilot - VOR radial, DME range) is to be specified as a check point for timing of successive approaches;
- Aircraft are to be given a time at which to pass the specified point inbound (the purpose of which is to achieve the desired interval between successive landings on the runway while respecting the applicable separation minima at all times including runway occupancy period). The time determined is to be passed to the pilot to allow sufficient time for him/her to arrange the flight to comply.

17.39 Expected approach time (EAT). An expected approach time shall be determined for an arriving aircraft that will be subjected to stacking, and shall be transmitted to the aircraft, as soon as practicable and preferably not later than at the commencement of its initial descent from cruising level. In the case of aircraft particularly sensitive to high fuel consumption at low levels, an expected approach time should, whenever possible, be transmitted to the aircraft early enough before its intended descent time to enable the pilot to choose the method of absorbing the delay and to request a change in the flight plan if the choice is to reduce speed en-route. A revised expected approach time shall be transmitted to the aircraft without delay whenever it differs from that previously transmitted by 5 minutes or more or such lesser period of time as has been established by the appropriate ATS authority or agreed between the ATS units concerned. An expected approach time shall be transmitted to the aircraft by the most expeditious means whenever it is anticipated that the aircraft will be required to hold for thirty minutes or more. The holding point to which an expected approach time relates shall be identified together with the expected approach time whenever circumstances are such that this would not otherwise be evident to the pilot.

17.40 Information for arriving aircraft. The following information is to be passed to aircraft during the approach phase:

- **When established.** As early as practicable after an aircraft has established communication with the approach controller, the following information, in the order listed, shall be transmitted to the aircraft, except where it is known the aircraft has already received it:
 - Runway-in-use;
 - Meteorological information;

Note: The meteorological information is identical to that required in ATIS broadcasts for aircraft arriving, and is to be extracted from meteorological reports disseminated locally at the aerodrome.

- Current runway surface conditions, in case of precipitants or other temporary hazards;
 - Changes in the operational status of visual and non-visual aids essential for approach and landing.
- **Commencing final approach.** At the commencement of final approach, the following information shall be transmitted to the aircraft:

- Significant changes in the mean surface wind direction and speed;

Note: Significant changes are detailed in Annex 3 (Met). If the controller has access to wind component tables, the following are considered to be significant:

- Mean head-wind component 10 kt
 - Mean tail-wind component 2 kt
 - Mean cross-wind component 5 kt
- The latest information, if any, on wind shear and/or turbulence in the final approach area;
 - The current visibility representative of the direction of approach and landing or, when provided, the current runway visual range value(s) and the trend, if practicable, supplemented by slant visual range value(s), if provided;
- **During final approach.** The following information shall be transmitted without delay;
- The sudden occurrence of hazards (for example: unauthorised traffic on the runway)
 - Significant variations in the current surface wind, expressed in terms of minimum and maximum values;
 - Significant changes in runway surface conditions
 - Changes in the operational status of required visual or non-visual aids;
- Changes in observed RVR value(s), in accordance with the reported scale in use, or changes in the visibility representative of the direction of approach and landing.

AIR TRAFFIC ADVISORY SERVICE

17.41 Establishment and Objective. The Air Traffic Advisory Service is defined as a service provided within advisory airspace (class F) to ensure separation between aircraft operating on IFR flight plans. In practice, this service is established in response to a request where the establishment of a full ATC service has not been determined. In other words, it is a temporary arrangement pending a decision on whether or not a full ATC service is required. The objective is to make information on collision hazards more effective than it would be in the provision of a flight information service only. It is provided to IFR flights in advisory airspace or on advisory routes.

17.42 Operation. The Air Traffic Advisory Service does not afford the degree of safety and does not assume the same responsibilities as a full ATC service. To this end clearances are not issued and only advice or suggestions are offered by the ATCOs. An IFR flight electing to use the service is expected to comply with the same procedures as would be in force in CAS, except that FPL changes are not subject to clearance. All IFR flights flying in class F airspace are required to file FPLs. Traffic electing to use the advisory service will receive an 'acknowledgement' of the submission of the FPL only. IFR flights crossing an advisory route are required to do so at 'right angles' to the route direction at a level appropriate to the semi circular rule.

AIRCRAFT EMERGENCIES

17.43 Use of SSR. Use of the reserved SSR codes is the most expeditious means of indicating a situation where an aircraft requires assistance. Clearly, the aircraft must be flying in an area where radar is used for ATC, and in this may be a factor of altitude. Even outside of radar control areas there are military facilities and mobile units that can interrogate and receive SSR information which can assist the alerting service to provide the necessary assistance. The reserved codes are:

- | | | |
|---|------------------|-----------------------|
| ➤ | Mode A code 7700 | Emergency |
| ➤ | Mode A code 7600 | Radio failure |
| ➤ | Mode A code 7500 | Unlawful Interference |

Additionally:

- | | | |
|---|------------------|--|
| ➤ | Mode A code 7000 | Conspicuity code for an aircraft operating in an area where a radar service is available but the aircraft is not in receipt of the service (commonly referred to as VFR conspicuity) |
| ➤ | Mode A code 2000 | An aircraft is operating in an area where a radar service is not available but will be entering an area where a radar service is available and will be requesting that service (this is used for eastbound NAT traffic east of 30W that intend entering the Scottish UIR). |

17.44 Aircraft Already Identified. If a pilot is already in receipt of a radar service and has been identified by the use of a discrete SSR code, selection of a reserved code to indicate a state of emergency may delay the application of the assistance. In this case the allocated Mode A code should be retained.

17.45 Emergency Descent. If an aircraft suffers a pressurisation failure at altitude, the rules require the aircraft to be descended to an altitude where oxygen in the air supports life. In the event, ATC will broadcast a warning to aircraft in the vicinity of a descending aircraft. The pilot of the descending aircraft should attempt to broadcast the aircraft altitude at intervals to assist other aircraft to avoid a collision.

17.46 Fuel Jettison. In certain circumstances, it may be necessary to reduce the mass of the aircraft to maximum landing mass as soon as possible by dumping as much fuel as is required. All aircraft which have a maximum take off mass greater than the maximum landing mass are required to have fuel jettison system. If the aircraft is flying in CAS, before commencing fuel jettison, the controlling ATCU is to be informed. The route over which the fuel is to be jettisoned should be clear of towns, preferably over water and clear of areas where thunderstorm activity has been reported or is expected. The level at which the jettison takes place is to be not lower than 6000ft. This will allow the fuel in aerosol form to evaporate before reaching the ground. The ATCU is to be advised of the duration of the

QUESTIONS

1. In what class of airspace is an advisory service provided for participating IFR traffic and a FIS for all other traffic?
 - a. C
 - b. D
 - c. C
 - d. F

2. List the services that must be provided in a FIR:
 - a. FIS only.
 - b. FIS, advisory ATC, ATC.
 - c. FIS, aerodrome control.
 - d. FIS, alerting service.

3. An aircraft has been cleared to land and fails to do so within 5 minutes of the ETA of landing and communications have not been re-established with the aircraft. What phase of the Alerting Service will be declared?
 - a. DETRESFA.
 - b. INCERFA.
 - c. ALERFA.
 - d. EMERGFA.

4. When must QNH be passed to an aircraft prior to take-off?
 - a. In the taxi clearance.
 - b. On engine start-up request.
 - c. On first contact with ATC.
 - d. Just prior to take-off.

5. The necessary separation minima for controlled traffic in the vicinity of an aerodrome may be reduced when:
 - a. the commander of the aircraft requests reduced separation.
 - b. the aerodrome controller has the involved aircraft in sight.
 - c. the commander in the following aircraft has the preceding aircraft in sight and is able to maintain own separation.
 - d. directed by the aerodrome controller.

6. At commencement of final approach, if the approach controller has wind component information, what change in cross wind component change would be passed to the pilot?
 - a. 10 kts.
 - b. 8 kts.
 - c. 3 kts.
 - d. 5 kts.

7. For departure, 1 minute separation can be applied if the aircraft fly on diverging tracks immediately after take-off at least:
- 45°.
 - 15°.
 - 30°.
 - 2°.
8. During an approach, when can normal separation be reduced?
- When the controller has both aircraft in sight.
 - When the following aircraft has the preceding in sight and can maintain it.
 - When both pilots request it.
 - When both aircraft are under radar control.
9. For parallel runway operations, the missed approach tracks must diverge by:
- 15°.
 - 30°.
 - 45°.
 - 20°.
10. When the air traffic controller has wind information as components at the start of final approach, significant changes in the average surface wind direction and speed must be given to the pilot. The significant change of the average tailwind is:
- 5 kts.
 - 2 kts.
 - 4 kts.
 - 3 kts.
11. According to international agreements the wind direction, in degrees magnetic converted with local magnetic variation from the true wind direction must be passed to the pilot of an aircraft:
- before entering the traffic pattern or commencing an approach to landing, and prior to taxiing for take-off.
 - in anticipation of the upper wind for areas North of 60° N and South of 60° S.
 - when an aircraft is requested by the meteorological office or on specified points to give a AIREP.
 - when the local variation is greater than 10° East or West.
12. What is the closest to touchdown that a radar controller can request a change of speed to an aircraft on final approach?
- 5nm.
 - 3nm.
 - 2nm.
 - 4nm.
13. What defines a controlled aerodrome?
- It must be located within a CTR.
 - It must have a control tower giving an ATC service.
 - It must have a control tower and be in a CTR.
 - It must be in controlled airspace.

14. What is the primary use for Radar in ATC?
 - a. Separation.
 - b. Helping when aircraft communications have failed.
 - c. To assist pilots with technical problems.
 - d. To assist pilots of aircraft that are lost.

 15. When must the SSR transponder be operated?
 - a. Always.
 - b. At all times unless otherwise instructed by ATC.
 - c. At the pilot's discretion regardless of ATC instructions.
 - d. Mode A always; Mode C at pilots discretion.

 16. What is the minimum distance from threshold that a controller must have issued clearance to land by, for a non precision approach?
 - a. 5 nm.
 - b. 2 nm.
 - c. 3 nm.
 - d. 10 nm.

 17. The maximum speed change that may be required during a radar approach is:
 - a. ± 40 kts.
 - b. ± 5 kts.
 - c. ± 10 kts.
 - d. ± 20 kts.

 18. What is the distance on final approach within which the controller should suggest that the aircraft executes a missed approach if the aircraft either is lost from the radar for a significant time, or the identity of the aircraft is in doubt?
 - a. 1 nm.
 - b. 2 nms.
 - c. 3 nms.
 - d. 4 nms.

 19. What is the closest point to the threshold that a radar controller may request a speed change?
 - a. 1 nm.
 - b. 2 nms.
 - c. 3 nms.
 - d. 4 nms.

 20. An aircraft in receipt of a radar service is told to "resume own navigation". What does this mean?
 - a. The pilot is responsible for own navigation.
 - b. Radar vectoring is terminated.
 - c. The pilot should contact next ATC unit.
 - d. The pilot should contact the current ATC unit.
-

21. What is standard radar separation?
- 5nm.
 - 3nm.
 - 10nm.
 - 2.5nm.
22. By how much will a radar controller turn an aircraft to identify that aircraft on the radar?
- 45°.
 - 15°.
 - 30° or more.
 - a minimum of 25°.
23. What is the acceptable tolerance for Mode 'C' altitude indication (not in RVSM airspace)?
- ± 100 ft.
 - ± 150 ft.
 - ± 300 ft.
 - ± 200 ft.
24. When may the pilot operate the 'IDENT' switch on the transponder?
- Only in controlled airspace.
 - When instructed by ATC.
 - Only in uncontrolled airspace.
 - Only when under radar control.
25. If you are given an instruction by ATC to steer heading 030, is the heading:
- degrees true and must be corrected for wind.
 - degrees magnetic and must be corrected for wind.
 - degrees true no correction to be applied.
 - degrees magnetic no correction to be applied.
26. When would you squawk SSR mode C?
- Only when directed by ATC.
 - Always.
 - Always in controlled airspace.
 - Only in controlled airspace.
27. If radar contact is lost during an approach, at what range from touchdown would ATC order a missed approach to be flown?
- 1 nm.
 - 2 nm.
 - 3 nm.
 - 4 nm.

28. When is an aircraft considered to have left the allocated flight level in the descent when referencing altitude to Mode C?
- Once it has descended through 100 ft.
 - Once it has descended through 200 ft.
 - Once it has descended through 300 ft.
 - Once it has descended through 500 ft.
29. If you are intercepted by a military aircraft, what do you set on the SSR transponder?
- A/2000 + C.
 - A/7500 + C.
 - A/7600 + C.
 - A/7700 + C.
30. Aerodrome traffic is considered to be:
- aircraft on the movement area and flying in the vicinity.
 - aircraft on the manoeuvring area and flying in the vicinity.
 - aircraft on the movement area only.
 - aircraft on the manoeuvring area only.
31. The criterion that determines the specific level occupied by an aircraft based on Mode C information (except where the appropriate ATC authority specifies a lesser criterion) is:
- +/- 300 ft.
 - +/- 150 ft.
 - +/- 250 ft.
 - +/- 200 ft.
32. If approved by the authority within 40 nm of the radar transmitter, radar separation can be reduced to:
- 5 nms.
 - 4.5 nms.
 - 4 nms.
 - 3 nms.
33. How close to the boundary of a radar vectoring area can an aircraft be vectored?
- 2nm.
 - 2.5nm.
 - 5nm.
 - 3nm.
34. A radar controller can request an aircraft to change speed when it is on the intermediate and final approach phase, except in certain conditions specified by the proper ATS authority. The speed change must not be more than:
- ± 15 kts.
 - ± 8 kts.
 - ± 10 kts.
 - ± 20 kts.

35. What does the ATC term "radar contact" mean?
- The aircraft is identified and will receive separation from all aircraft while you are communicating with this radar facility.
 - ATC is receiving your transponder and will provide you with vectors and advice concerning traffic, until you are notified that contact is lost.
 - Your aircraft is seen and identified on the radar display and until further advised a service will be provided.
 - You will receive radar advisory concerning traffic until you are notified that the contact is lost or radar service is terminated.
36. The "land after" procedure may only be applied during:
- daylight hours only.
 - night or day.
 - VMC.
 - IMC.
37. An aircraft making a radar approach must be told to make a missed approach, when no landing clearance has been received from the non-radar traffic controller, when the aircraft is at a distance of:
- 5 nms from the touchdown.
 - 1.5 nms from the touchdown.
 - 4 nms from the touchdown.
 - 2 nms from the touchdown.
38. A radar controller cannot ask a pilot to change speed if the aircraft is within:
- 4 nms from the threshold on final approach.
 - 5 nms from the threshold on final approach.
 - 2 nms from the threshold on final approach.
 - 3 nms from the threshold on final approach.
39. When an aircraft's SSR transponder appears to be unserviceable prior to departure and repair is not possible:
- the pilot must indicate the failure in the flight plan, after which ATC will approve the operation of the aircraft without SSR.
 - if required by ATC, departure to the nearest suitable airport where repair can be effected will be approved.
 - the pilot will not be allowed to commence the flight.
 - the flight can only continue in the most direct manner.
40. Using SSR, a method by which a radar controller may identify an aircraft is to ask the pilot to:
- set a specific SSR Code.
 - switch from "off" to "on".
 - switch to "off".
 - switch to "on".

ANSWERS

Question	Answer	Reference	Question	Answer	Reference
1.	D	17.41	21.	A	17.7
2.	D	15.25	22.	C	17.8
3.	C	15.38	23.	C	13.6
4.	A	17.24	24.	B	13.4
5.	C	17.22	25.	D	17.13
6.	D	17.40	26.	B	13.6
7.	A	16.45	27.	B	17.15
8.	B	17.22	28.	C	13.13
9.	B	12.13	29.	D	6.48
10.	B	17.40	30.	B	Definitions
11.	A	17.24	31.	A	13.13
12.	D	17.35	32.	D	16.33
13.	B	Chap 1	33.	B	17.13
14.	A	17.5	34.	D	13.35
15.	B	13.2	35.	A	17.9
16.	B	17.21	36.	A	17.22
17.	D	17.35	37.	D	17.15
18.	B	17.15	38.	A	17.35
19.	D	17.35	39.	B	13.7
20.	B	17.12	40.	A	17.8

CHAPTER EIGHTEEN

AERONAUTICAL INFORMATION SERVICE (AIS)

Contents

INTRODUCTION	325
GENERAL.	325
THE INTEGRATED AERONAUTICAL INFORMATION PACKAGE	326
THE AERONAUTICAL INFORMATION PUBLICATION (AIP).	326
NOTICES TO AIRMEN (NOTAM).	329
SNOWTAM.	330
ASHTAM	332
AERONAUTICAL INFORMATION CIRCULARS (AICs).	333
PRE-FLIGHT AND POST-FLIGHT INFORMATION	334
QUESTIONS	337
ANSWERS	340

INTRODUCTION

18.1 Objectives of the AIS. The safety, regularity and efficiency of international air navigation rely on an organized and efficient flow of information. Pilots and Operators must have information concerning the availability of aerodromes, navigation facilities and ATS routes to enable a scheduled flight to take place. Air Traffic Controllers require the same information but also need information from pilots to ensure safety. The provision of this information, its handling and dissemination (publication) is the responsibility of the Aeronautical Information Service of the state. Whilst it has always been necessary for such information to be available, the role and importance of aeronautical information/data has changed significantly with the implementation of area navigation (RNAV), required navigation performance (RNP) and airborne computer-based navigation systems. Corrupt or erroneous aeronautical information/data can potentially affect the safety of air navigation. The introduction of precision RNAV approach systems, using GLS (GPS based landing systems) is another example of the need for precise information being available at all times to ensure the success of the system.

18.2 Annex 15. The ICAO document concerning the Standards and Recommended Practices for the provision of the AIS and which contains the material relevant to the learning objectives is Annex 15 to the Convention on Civil Aviation.

GENERAL

18.3 Functions. Each Contracting State is required to provide an aeronautical information service; or agree with one or more other Contracting State(s) for the provision of a joint service; or delegate the authority for the service to a non-governmental agency, provided the Standards and Recommended Practices of Annex 15 are adequately met.

18.4 Responsibilities. The State concerned shall remain responsible for the information published. Aeronautical information published for and on behalf of a State shall clearly indicate that it is published under the authority of that state. Each Contracting State shall take all necessary measures to ensure that aeronautical information/data it provides relating to its own territory, as well as areas in which the State is responsible for air traffic services outside its territory, is adequate, of required quality and timely. This shall include arrangements for the timely provision of required information to the aeronautical information service by each of the State services associated with aircraft operations.

18.5 Availability. Generally, the AIS will be available on a 24 hour a day basis. Where 24-hour service is not provided, service shall be available during the whole period an aircraft is in flight in the area of responsibility of an AIS plus a period of at least two hours before and after such period. The service shall also be available at such other time as may be requested by an appropriate ground organisation.

18.6 Sources of information. An AIS is also required to provide a pre-flight information service as well as in-flight information from the aeronautical information services of other States and from other sources that may be available.

18.7 Requirements of the service. Aeronautical information distributed by the AIS is to be verified by and attributable to the State of Origin. If this is not possible when distributed, the information must be clearly identified as such. The AIS is to make available any information necessary for the safety, regularity or efficiency of air navigation to any other State that requires the information. The information provided is to be in a form suitable for the operational requirements of flight operations personnel including flight crews, flight planning and flight simulator; and the ATSU responsible for the FIS within a FIR and the services responsible for pre-flight information.

18.8 Publication. The AIS is to receive and/or originate, collate or assemble, edit, format, publish/store and distribute aeronautical information/data concerning the entire territory of the State as well as areas in which the State is responsible for ATS outside its territory. Aeronautical information is published in the form of an Integrated Aeronautical Information Package (IAIP).

18.9 World Geodetic System - 1984 (WGS - 84). Since 1 January 1998, published geographical co-ordinates indicating latitude and longitude used in aviation have been expressed in terms of the World Geodetic System - 1984 (WGS - 84). Since 5 November 1998, in addition to the elevation (referenced to mean sea level) for the specific surveyed ground positions, geoid undulation (gravity variations caused by the varying radius of the Earth referenced to the WGS-84 ellipsoid) for those positions specified in the AIP AD section is also required to be published. This has implications for the orbits of satellites used in SatNav systems.

THE INTEGRATED AERONAUTICAL INFORMATION PACKAGE

18.10 Definition and contents. The Integrated Aeronautical Information Package is a system of dissemination of information essential to aviation operations and safety. It consists of the following elements:

- Aeronautical Information Publication (AIP - including amendment service)
- Supplements to the AIP
- NOTAM and pre-flight information bulletins (PIBs)
- Aeronautical Information Circulars (AICs)
- Checklists and Summaries

THE AERONAUTICAL INFORMATION PUBLICATION (AIP)

18.11 Use. The AIP (previously called the 'Air Pilot' in the UK) is designed to allow information of a generally 'static' nature to be published, if practicable, in a form that can be used in flight (i.e. instrument approach plates or SID plates). The AIP is required to be the definitive reference for permanent information and for information concerning long duration temporary changes. This means that aircrew and operators can rely on the information published to be accurate and up to date. The AIP does not contain aerodrome operating minima which are defined by the operator i.e. visual criteria to continue an instrument approach.

18.12 Contents. The AIP consists of three parts:

- Part 1 - General (GEN)
- Part 2 - En-route (ENR)
- Part 3 - Aerodrome Data (AD)

18.13 Part 1 - GEN. Part 1 contains information of a regulatory and administrative nature. It consists of five sections. It is important that to know that differences to the ICAO SARPS and PANS notified by the state publishing the AIP are detailed fully at GEN 1.7 (this is the usual method of referral to the AIP contents). The complete content of part 1 (by headings) is as follows but the learning objectives only require the student to recall the location of the information in bold italics:

- **GEN 0** Preface; Record AIP amendments; Record of AIP Supplements;

Checklist of AIP pages; List of hand amendments to Part 1; Table of Contents to Part 1;

- **GEN 1** National regulations and requirements - Designated authorities; Entry, transit and departure of aircraft; *Entry, transit and departure of passengers, crew and cargo; Aircraft instruments, equipment and flight documents*; Summary of national regulations and international agreements/conventions; *Differences from ICAO Standards and Recommended Practices*.
- **GEN 2** Tables and Codes - Measuring system, aircraft markings, holidays; Abbreviations used in AIS publications; Chart symbols; *ICAO 4 letter Location indicators*; List of Radio Navigation Aids; Conversion tables; Sunrise/Sunset tables; Rate of Climb Table.
- **GEN 3** Services - *Aeronautical Information Services*; Aeronautical Charts; Air Traffic Services; Communications Services; *Meteorological Services*; Search and Rescue.
- **GEN 4** Charges for aerodrome/heliport and air navigation services - Aerodrome/heliport charges; Air navigation service charges.

18.14 Part 2 - En-Route (ENR). This part contains information for planning flights. It also contains information of a procedural administrative nature to allow notification of flights (submission of a FPL) and compliance with ATC requirements. It consists of seven sections.

- **ENR 0** Preface: List of hand amendments to Part 2; Table of Contents of Part 2.
- **ENR 1** General rules and procedures - *General rules; Visual flight rules; Instrument flight rules*; ATS airspace classification; *Holding, Approach and Departure procedures*; Radar services and procedures; *Altimeter setting procedures*; Regional Supplementary procedures; Air Traffic flow management; Flight Planning; Addressing of flight plan messages; *Interception of civil aircraft; Unlawful interference; Air traffic incidents*; Off-shore operations.
- **ENR 2** *Air traffic services airspace* - Detailed description of Flight Information Regions (FIR); Upper Flight Information Regions (UIR); Terminal Control Areas (TMA); other regulated airspace.
- **ENR 3** *ATS routes* - Detailed description of Lower ATS routes; Upper ATS routes; Area navigation routes; Helicopter routes; Other routes; En-route holding; *Minimum flight Altitude*.
- **ENR 4** Radio Navigation aids/systems - Radio navigation aids - en route; Special navigation systems; Name-code designators for significant points; Aeronautical ground lights - en-route.
- **ENR 5** *Navigation warnings - Prohibited, restricted and danger areas*; Military exercise and training areas; Other activities of a dangerous nature; Air navigation obstacles - en-route; Aerial sporting and recreational activities; Bird migration and areas of sensitive fauna.
- **ENR 6** En-route charts - En-route Chart ICAO and index charts.

18.15 Part 3 - Aerodromes. This part consists of four sections containing information concerning aerodromes (and heliports). Each aerodrome entry contains specified information in accordance with a set schedule. For instance, AD2.3 for EGLL (Heathrow) contains details of operational hours of the aerodrome; AD2.3 for EGTK (Oxford) contains the same information applicable to that aerodrome. The contents are:

- **AD 0** Preface; List of hand amendments to Part 3; Table of Contents to Part 3.
- **AD 1** Aerodrome/Heliports - Introduction - Aeronautical/helicopter availability; Rescue and fire fighting services and snow plan; Index to aerodromes and heliports; Grouping of aerodromes/heliports.
- **AD 2** Aerodromes - Detailed information about aerodromes (including helicopter landing areas if located at the aerodromes) listed under 24 sub-sections, including information concerning: Aprons, taxiways and check locations; surface movement guidance and control systems and markings; radio navigation and landing aids; charts relating to an aerodrome; *refuelling facilities*.
- **AD 3** Heliports - Detailed information about heliports (not located at aerodromes), listed under 23 sub-sections.

18.16 AIP Amendments. All changes to the AIP, or new information on a reprinted page, is identified by a distinctive symbol or annotation. In the UK this is a vertical black line in the page margin adjacent to the amended/new data. The AIP is amended or reissued at regular intervals as are necessary to keep the data up to date. The normal method of amendment is by replacement pages. Permanent changes to the AIP are published as AIP amendments. Each AIP amendment is allocated a consecutive serial number and each amended page, including the cover sheet, shows the publication date.

18.17 AIRAC. Operationally significant changes to the AIP are published in accordance with Aeronautical Information Regulation and Control procedures, and shall be clearly identified by the acronym - AIRAC. Each AIRAC AIP amendment page, including the cover sheet, must display an effective date. AIRAC is based on a series of common effective dates at intervals of 28 days (started 10 Jan 91). AIRAC information is distributed by the AIS unit at least 42 days in advance of the effective date and the information notified must not be changed for at least another 28 days after the effective date, unless the circumstance notified is of a temporary nature and would not persist for the full period. Whenever major changes are planned and where additional notice is desirable, a publication date 56 days in advance of the effective date should be used.

18.18 AIP Supplements. Temporary changes of long duration (three months or longer) and information of short duration which contains extensive text and/or graphics are published as AIP supplements. Each AIP Supplement is allocated a serial number which shall be consecutive and based on the calendar year. AIP Supplement pages are kept in the AIP as long as all or some of their contents remain valid. When an AIP Supplement is sent in replacement of a NOTAM, it is to include a reference to the serial number of the NOTAM. A checklist of AIP Supplements currently in force is issued at intervals of not more than one month (i.e. monthly or more frequent). AIP Supplement pages should be coloured in order to be conspicuous, preferably in yellow.

NOTICES TO AIRMEN (NOTAM)

18.19 Definition: NOTAM are notices distributed by means of telecommunications containing information concerning the establishment, condition or change in any aeronautical facility, service, procedure or hazard, the timely knowledge of which is essential to personnel concerned with flight operations.

18.20 Origination. NOTAM are to be originated and issued promptly whenever the information to be distributed is of a temporary nature and of short duration, or when operationally significant permanent changes, or temporary changes of long duration, are made at short notice (except when extensive text and/or graphics is essentially included, in which case, the information is published as an AIP supplement). NOTAM are required whenever information is of direct operational significance.

18.21 AIRAC notification. When an AIP amendment or an AIP Supplement is published in accordance with AIRAC procedures (see 18.4.7), NOTAM are to be originated giving a brief description of the contents, the effective date and the reference number to the amendment supplement. This NOTAM shall come into force on the same effective date as the amendment or supplement.

18.22 Notice and validity. NOTAM should remain in force as a reminder in the pre-flight information bulletin until the next checklist/summary is issued. Whenever possible, at least 24 hours' advance notice is desirable, to permit timely completion of the notification process and to facilitate airspace utilization planning. NOTAM notifying the unserviceability of aids to air navigation, facilities or communication services should give an estimate of the period of unserviceability or the time at which restoration of service is expected.

18.23 Excluded matter. NOTAM should not include information of non operational importance including partial failures of lighting or ground systems, routine maintenance, any work in progress on runways not in use or if the equipment can be rapidly removed from the duty runway, temporary obstructions, local area parachuting, and the lack of apron marshalling services and road traffic control.

18.24 Distribution. NOTAM are to be distributed to addressees to whom the information is of direct operational significance, and who would not otherwise have at least seven days prior notification. The aeronautical fixed telecommunication network (AFTN - teleprinter) is, whenever practicable, employed for NOTAM distribution. When NOTAM are sent by means other than the AFTN a six digit date-time group indicating the date and time of filing the NOTAM and the identification of the originator is used, preceding the text.

18.25 NOTAM Checklists. A checklist of current NOTAM is issued at intervals of not more than one month. The checklist is to refer to the latest AIP Amendment, AIP Supplement and the internationally distributed AICs.

18.26 Summary. A monthly printed plain language summary of NOTAM in force, including the indications of the latest AIP Amendments, checklist of AIP Supplements and AIC issued, is to be sent by the most expeditious means to recipients of the IAIP.

SNOWTAM

18.27 Description. Information concerning snow, ice and standing water on aerodrome pavement areas is to be reported by SNOWTAM.

18.28 Contents of a SNOWTAM. Appendix 2 to Annex 15 details the requirements of a SNOWTAM. The information contained is as follows (If a field is not applicable then it is left blank and nothing is transmitted):

- A. The ICAO aerodrome locator code e.g. EGLL (Heathrow)
- B. The date/time of observation (UTC)
- C. Runway designators (e.g. 27R)
- D. Cleared runway length if less than published length (m)
- E. Cleared runway width if less than the published width (m; if off set: L or R)
- F. Deposits over total runway length:
 - Nil - Clear and dry
 - Damp
 - Wet or water patches
 - Rime or frost covered
 - Dry snow
 - Wet snow
 - Slush
 - Ice
 - Compacted or rolled snow
 - Frozen ruts or ridges
- G. Mean depth (mm) for each third of total runway length
- H. Friction measurement on each third of runway and friction measuring device

Friction Co-efficient	Estimated surface friction	Code
0.4 and above	Good	5
0.39 – 0.36	Medium to good	4
0.35 – 0.3	Medium	3
0.29 – 0.26	Medium to poor	2
0.25 and below	Poor	1
Reading unreliable	Unreliable	9

Figure 18.1: Surface friction reporting codes.

- J. Critical snow banks (m)
- K. Runway lights (if obscured "yes" followed by L , R or LR)
- L. Further clearance (if planned inset length/width to be cleared or if to full dimensions insert FULL)
- M. Further clearance expected to be completed by (UTC)
- N. Taxiway
- P. Taxiway snow banks (if >60cm insert "Yes" followed by distance apart (m))
- Q. Apron
- S. Next planned observation /measurement is for (month/day/hour (UTC))
- T. Plain language remarks

18.29 SNOWCLO. A term used in a VOLMET Broadcast to indicate that an aerodrome is closed due to snow or snow clearance in progress.



Photo: Mercedes Benz

Figure 18.2: Snow clearance.

18.30 Wheel Braking On Wet Runways. The inherent friction characteristics of a runway surface deteriorate only slowly over a period of time, but the friction of a runway surface and thus the braking action can vary significantly over a short period in wet conditions depending on the actual depth of water on the runway. Also, long term (six monthly) seasonal variations in friction value may exist. The consequence of combination of these factors is that no meaningful operational benefit can be derived from continually measuring the friction value of a runway in wet conditions. In the context of these paragraphs a 'wet runway' covers a range of conditions from 'Damp' to 'Flooded' as described below. It does not include ice or runways contaminated with snow, slush, or water associated with slush. Paved runways of 1200 m and longer at Civil aerodromes licensed for public use have been calibrated, to ensure that the friction characteristics of a runway surface, are of a quality to provide good braking action in wet conditions. The presence of water on a runway will be reported on R/T using the following descriptions:

Description	Meaning
Dry	The surface is dry
Damp	The surface shows a change of colour due to moisture
Wet	The surface is soaked but no significant patches of standing water are visible.
Water Patches	Significant patches of standing water are visible
Flooded	Extensive standing water is visible.

Figure 18.3: Runway surface description.

18.31 Interpretation. When a runway is reported as 'DAMP' or 'WET' pilots may assume that an acceptable level of runway wheel braking friction is available. When a runway is reported as having 'WATER PATCHES' or being 'FLOODED' braking may be affected by aquaplaning and appropriate operational adjustments should be considered. "Water patches" will be used if at least 25% of the runway length is covered with standing water. When a runway is notified as liable to be slippery when wet, take-offs or landings in wet conditions should only be considered when the distances available equal or exceed those required for a very slippery or icy runway as determined from information in the aeroplane's Flight Manual. At military aerodromes in the UK, runway surface conditions will be described in plain language, and, where a braking action measuring device has been used, braking action will be described as good, medium or poor.

ASHTAM

18.32 Purpose. Volcanic ash cloud presents a significant hazard to turbine engine aeroplanes. Timely warning of the presence of ash clouds or the possibility of an ash cloud existing is vital to safe operations in areas where volcanic activity is common. Information concerning an operationally significant change in volcanic activity, a volcanic eruption and/or volcanic ash cloud is reported by means of an ASHTAM.

18.33 Description. The ASHTAM provides information on the status of activity of a volcano when a change in its activity is, or is expected to be of operational significance. This information is provided using the volcano level of alert colour code. In the event of a volcanic eruption producing ash cloud of operational significance, the ASHTAM also provides information on the location, extent and movement of the ash cloud and the air routes and flight levels affected. The maximum period of validity of an ASHTAM is 24 hours. A new ASHTAM must be issued whenever there is a change in the alert level.

18.34 ASHTAM Colour Code. The table below details the volcano alert code used in field E of an ASHTAM:

Colour	Description of Volcanic Activity
Red	Volcanic eruption in progress. Pyroclastic ash plume/cloud reported above FL 250, or volcano dangerous, eruption likely, with pyroclastic ash plume/cloud expected to rise above FL 250
Orange	Volcanic eruption in progress. Pyroclastic ash plume/cloud not reaching nor expected to reach FL 250, or volcano dangerous, eruption likely, with pyroclastic ash plume/cloud not expected to reach FL250
Yellow	Volcano known to be active from time to time and volcanic activity has recently increased significantly, volcano not currently considered dangerous but caution should be exercised, or after a volcanic eruption (i.e. change in alert to yellow from red or orange) volcanic activity has decreased significantly, volcano not currently considered dangerous but caution should be exercised.
Green	Volcanic activity considered to have ceased and volcano reverted to its normal state.

Figure 18.4: ASHTAM colour code.

AERONAUTICAL INFORMATION CIRCULARS (AICs)

18.35 Description. AICs are a method whereby information that doesn't qualify for inclusion in the AIP or is not suitable for NOTAM is disseminated to all interested parties. An AIC is originated whenever it is desirable to promulgate: a long-term forecast of any major change in legislation, regulations, procedures or facilities; information of a purely explanatory or advisory nature liable to affect flight safety; or information or notification of an explanatory or advisory nature concerning technical, legislative or purely administrative matters.

18.36 General specifications of AICs. AICs are issued in printed form, and both text and diagrams may be included. The originating State can select the AICs that are to be given international distribution. AICs are allocated a serial number which should be consecutive and based on the calendar year. When AICs are distributed in more than one series, each series is separately identified by a letter. It is normal for differentiation and identification of AIC topics according to subjects to use a colour coding system (i.e. the paper on which the information is published is distinguished by topic by different colour). A checklist of AIC currently in force is issued at least once a year, with distribution as for the AIC. AICs in the UK are published on Thursdays every 28 days.

37.37 **Colour coding of UK AICs.** In the UK the following colour coding scheme for AICs is adopted.

Colour	Meaning
Pink	Matters relating to safety
Yellow	Operational matters including ATS facilities and requirements
White	Administrative matters i.e. exam dates and fees
Mauve (Purple)	UK airspace reservations imposed in accordance with applicable regulations
Green	Maps and Charts

Figure 18.5: Colour coding of AICs.

PRE-FLIGHT AND POST-FLIGHT INFORMATION

18.39 Pre-flight information. At any aerodrome normally used for international air operations, aeronautical information essential for the safety, regularity and efficiency of air navigation and relative to the route stages originating at the aerodrome must be made available to flight operations personnel, including flight crews and services responsible for pre-flight information. Aeronautical information provided for pre-flight planning purposes at the aerodromes must include: relevant elements of the Integrated Aeronautical Information Package; and maps and charts. The documentation may be limited to national publications and when practicable, those of immediately adjacent states, provided a complete library of aeronautical information is available at a central location and means of direct communications are available between the aerodrome AIS unit and that library.

18.40 Aerodrome information. Additional current information relating to the aerodrome of departure shall be provided concerning the following:

- Construction or maintenance work on or immediately adjacent to the manoeuvring area;
- Rough portions of any part of the manoeuvring area, whether marked or not (For example: broken parts of the surface of runways and taxiways)
- Presence and depth of snow, ice or water on runways and taxiways, including their effect on surface friction;
- Snow drifted or piled on or adjacent to runways or taxiways;
- Parked aircraft or other objects on or immediately adjacent to taxiways;
- Presence of other temporary hazards including those created by birds;

- Failure or irregular operation of part or all of the aerodrome lighting system including approach, threshold, runway, taxiway, obstruction and manoeuvring area unserviceability lights and aerodrome power supply;
- Failure, irregular operation and changes in operation status of ILS (including markers) SRE, PAR, DME, SSR, VOR, NDB, VHF aeronautical mobile channels, RVR observing system, and secondary power supply;
- Presence and operations of humanitarian relief missions, such as those undertaken under the auspices of the United Nations, together with any associated procedures, and/or limitations applied thereof;

18.41 PIBs. A recapitulation of current NOTAM and other information of urgent character shall be made available to flight crews in the form of plain language pre-flight information bulletins (PIB).

18.42 Post-flight information. States shall ensure that arrangements are made to receive at aerodromes/heliports information concerning the state and operation of air navigation facilities noted by aircrews, and shall ensure that such information is made available to the aeronautical information service for such distribution as the circumstances necessitate.

QUESTIONS

1. What level of alert would be inserted in field E of an ASHTAM following a volcanic eruption in which a pyroclastic ash cloud extends above FL250?
 - a. Red alert.
 - b. Orange alert.
 - c. Yellow alert.
 - d. Green alert.

 2. In which section of the AIP would you find information on holding, approach and departing procedures?
 - a. GEN.
 - b. ENR.
 - c. SAT.
 - d. AD.

 3. An integrated aeronautical information package consists of:
 - a. AIP and amendment service, supplement to the AIP, NOTAM, Pre-flight Information Bulletins (PIBs), AICs, checklists and summaries.
 - b. AIP and amendment service, NOTAM, Pre-flight Information Bulletins (PIBs), and AICs, AIRAC, checklists and summaries.
 - c. AIP and amendment service, supplement to the AIP, NOTAM, AIRAC, AICs, checklists and summaries.
 - d. AIP & Supplements, AIRAC, NOTAM and pre-flight bulletins.

 4. In what section of the AIP are details of SIGMET found?
 - a. GEN.
 - b. ENR.
 - c. AD.
 - d. COMMS.

 5. Where in the AIP is a list of Location Indicators to be found?
 - a. GEN.
 - b. COMMS.
 - c. AD.
 - d. AGA.

 6. A check list for NOTAM is issued:
 - a. every 5 days.
 - b. every 28 days.
 - c. every 18 days.
 - d. at intervals of not more than one month.

 7. AIP approach charts do not give information for Instrument Approach Procedures for:
 - a. OCA/H.
 - b. visibility minima.
 - c. obstacles protruding above the obstacle free zone.
 - d. DME frequencies.
-

8. AIP supplements with extensive text and graphics cover a short period. What is a long period in this respect?
- 1 yr.
 - 2 months.
 - 3 months.
 - 6 months.
9. AIRAC is:
- a breakdown service.
 - operationally significant changes to the AIP.
 - a medical evacuation flight.
 - an Army Air Corps publication.
10. What information is not on an aerodrome approach plate?
- DME frequency.
 - OCA.
 - Dominant obstacles.
 - Operating minima if the aerodrome is being used as an alternative.
11. Where in the AIP is information concerning re-fuelling facilities and services found?
- ENR.
 - SUPP.
 - AD.
 - GEN.
12. Where in the AIP would you find information concerning prohibited, restricted or danger areas?
- ENR.
 - SUPP.
 - AD.
 - GEN.
13. In what part of the AIP are the details of SIGMET found?
- GEN.
 - ENR.
 - AD.
 - AIRAC.
14. What is the co-efficient of braking, if the braking action is reported as medium?
- Between 1.0 and 0.25.
 - Between 0.25 and 0.3.
 - Between 0.30 and 0.35.
 - Between 0.35 and 0.4.

15. Regarding the AIS what is the time limit for a checklist of current NOTAM to be issued?
 - a. 7 days.
 - b. 14 days.
 - c. 28 days.
 - d. One month.

16. A checklist of the active NOTAM must be published on the AFTN at intervals of:
 - a. not more than 28 days.
 - b. not more than 15 days.
 - c. not more than 1 month.
 - d. not more than 10 days.

17. Operationally significant changes to the AIP shall be published in accordance with:
 - a. AICs.
 - b. AIP Supplements.
 - c. AIRAC procedures.
 - d. trigger NOTAMS.

18. A notice containing information concerning flight safety, air navigation, administration or legislative matters and originated at the AIS of a state is called:
 - a. Aeronautical Information Publication (AIP).
 - b. Aeronautical Information Circular (AIC).
 - c. AIRAC.
 - d. NOTAM.

ANSWERS

Question	Answer	Reference
1.	A	18.34
2.	B	18.14
3.	A	18.10
4.	A	18.13
5.	A	18.13
6.	D	18.25
7.	B	18.11
8.	C	18.18
9.	B	18.17
10.	D	18.11
11.	C	18.15
12.	A	18.14
13.	A	18.13
14.	C	18.28
15.	D	18.25
16.	C	18.25
17.	C	18.17
18.	B	18.35

CHAPTER NINETEEN

AERODROMES PHYSICAL CHARACTERISTICS

Contents

INTRODUCTION	343
AERODROME REFERENCE CODE	344
GLOSSARY OF TERMS	346
AERODROME DATA	348
RUNWAYS	350
TAXIWAYS	354
APRONS	359
QUESTIONS	360
ANSWERS	364

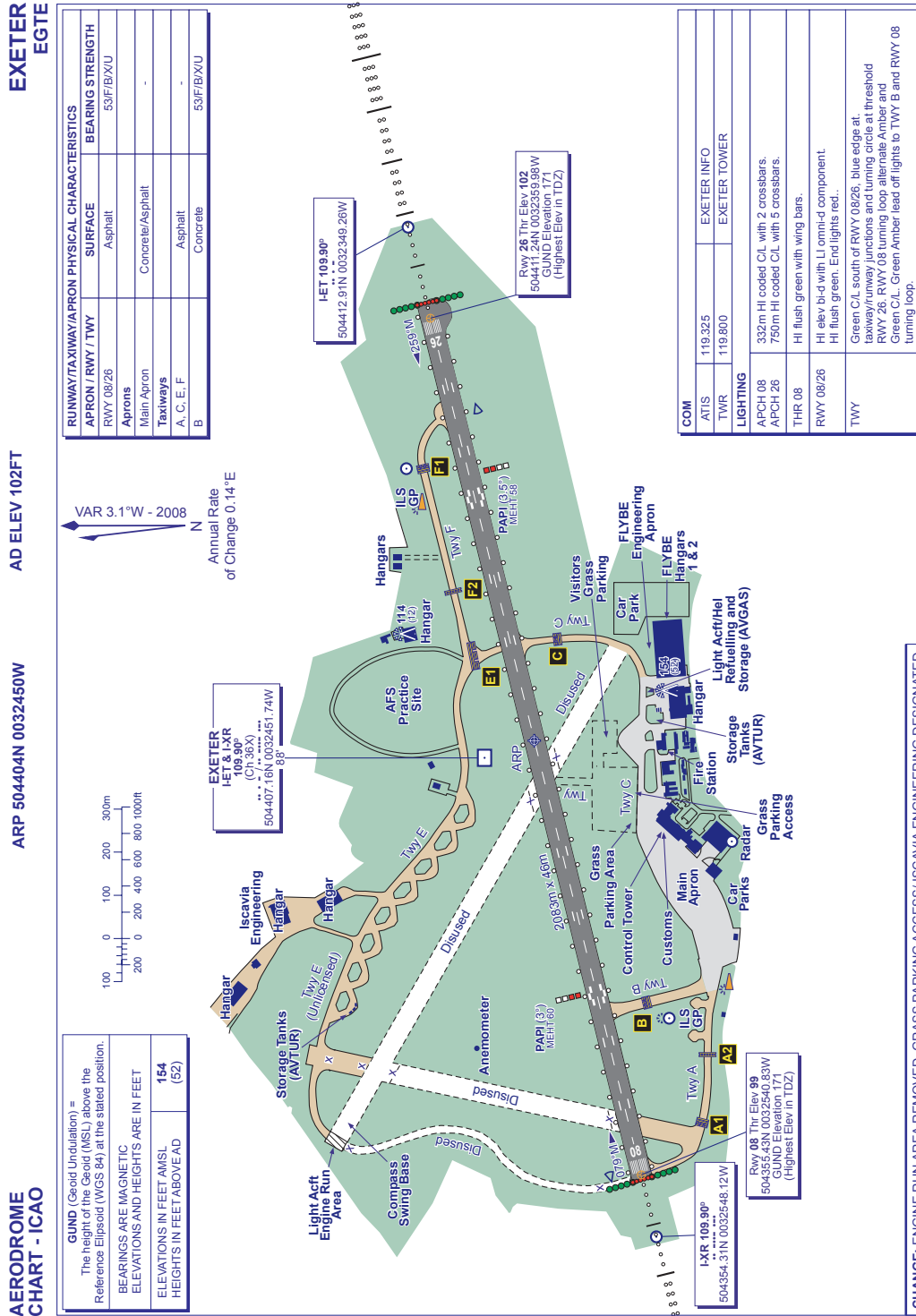

Figure 19.1:

Note: the Movement Area includes the apron, the manoeuvring area and the technical area.
The aeronautical part = inside the security area, including buildings.

INTRODUCTION

19.1 Aerodromes. The place on the surface of the Earth where aeroplanes (aircraft) take off and land is known as an aerodrome. Aerodromes may be nothing more than a field used for light private flying, a defined strip of open water (a water aerodrome) or the complex and fascinating areas of real estate we associate with places like Heathrow, Gatwick, Chicago O'Hare, JFK etc... The one thing they all have in common is that they are all provided especially for the use of aeroplanes. In this chapter of the notes discussion will be limited to the physical construction of land aerodromes with emphasis on the aerodromes used for international commercial aviation. There is widely differing terminology used with reference to aerodromes mostly colloquial and usually incorrect in interpretation. For instance, an airfield is exactly that: a field (usually unprepared) which is occasionally used as a landing ground for aeroplanes. An airport is a portal (entry) into a state for people and cargo which arrives by air, just as a sea port is the same for arrival by ship. The accepted and legally correct term is an aerodrome.

19.2 Annex 14. The annex to the Conference on International Civil Aviation that is concerned with aerodromes is Annex 14. In common with other annexes, it contains standards and recommended practices (SARPs) and states can notify differences to Annex 14 under article 38 of the convention. In accordance with article 15 of the convention, Annex 14 is only concerned with aerodromes that are open to the public. Each contracting state is required to ensure that such aerodromes comply with the requirements of the annex. In the United Kingdom, the authority responsible for ensuring compliance is the CAA. In the UK there are 4 types of aerodrome:

- Public use licensed aerodrome (open for general use on an equal basis)
- Ordinary (private) licensed aerodrome (use by licence holder and others with licence holder's permission only)
- Unlicensed aerodrome (limited use only)
- Government owned (Military, DERA etc.)

19.3 Use by Commercial Air Transport. The learning objectives of the course are directed towards the use of aerodromes by commercial air transport (CAT). The differentiation between public and private (ordinary) is immaterial. If an aerodrome is to be used for CAT, the services, facilities, markings, lighting and aircraft handling capability must comply with the requirements of the state for the issue of a licence. The use of an unlicensed aerodrome is not precluded for CAT, but the absence of a licence means that any instrument procedures associated with instrument approaches have not been certified as safe for use for CAT. It is therefore implicit that the use of an unlicensed aerodrome for CAT is restricted to visual operations only.

19.4 International Airports. Each state has the right to impose immigration, health and customs and excise controls on persons and cargo entering that state. An aerodrome at which such procedures and facilities for those controls are established and operated is known as an International Aerodrome. The place name of the aerodrome is usually suffixed with the word 'international' to denote the fact. For instance 'Los Angeles International'. In the UK such aerodromes are defined as 'customs aerodromes' although the term 'international' is becoming common place i.e. Birmingham International. As the student will recall, the Montreal Convention is only concerned with acts of unlawful interference committed at an 'international' aerodrome.

19.5 Basic layout. All aerodromes complying with the SARPs of Annex 14 have a movement area, a manoeuvring area and an apron. The 'real estate' of an aerodrome is generally covered by the requirements of the licence but certain safety features associated with large aerodromes may fall outside the control of the licensing authority and be devolved to the local civil planning authority. For instance the erection of a 30 storey block of flats half a mile from the end of runway 27R at Heathrow would not be permitted by the local planning authority. At a controlled aerodrome there must be an ATC control tower which has a visual control room (VCR). If the aerodrome accepts non-radio traffic, there must be a signals area laid out on the ground so that it is visible from the air within a defined distance and height from the aerodrome. The omission signal square implies that the aerodrome cannot accept non-radio traffic. The signals used have already been covered in the Rules of the Air. The physical construction of an aerodrome will depend upon the requirements of the aeroplanes using it and the required availability (utilisation) of the aerodrome and its services.

19.6 Movement Area. This is defined as: that part of an aerodrome intended for the surface movement of aircraft including the manoeuvring area, aprons and any part of the aerodrome provided for the maintenance of aircraft. Effectively, this is all the 'real estate' of the aerodrome. It may include grass areas where these are specified for aircraft use, but clearly does not include buildings and other constructed facilities.

19.7 Manoeuvring Area. This is defined as: that part of an aerodrome provided for the take-off and landing of aircraft and for the movement of aircraft on the surface, excluding the apron and any part of the aerodrome used for the maintenance of aircraft. The manoeuvring area will include runways (grass and paved), the taxiways (grass and paved) and any defined stop way or pre take off areas before the threshold of a runway.

19.8 Apron. The apron is a legally defined portion of the aerodrome where passengers, mail and cargo are loaded on to an aeroplane. It is commonly called the 'ramp' in the US. It is also the place where the pilot is required to check the accuracy of the altimeter(s). At busy commercial aerodromes, ATC delegates the safe movement of aircraft on the apron to the Apron Management Service. This is usually provided by an organisation contracted to the aerodrome authority specialising in the provision of baggage handling, refuelling, and marshalling and associated transportation requirements.

19.9 Aeronautical Part. This again is a legal definition of that portion of the aerodrome, this time including buildings and facilities, which are not accessible without security control. A commonly used term is 'air-side'.

AERODROME REFERENCE CODE

19.10 Use. The reference code, which is used for aerodrome planning and construction purposes, is a simple method of inter-relating the specifications concerning the characteristics of aerodromes, so as to provide aerodrome facilities that are suitable for the aeroplanes that are intended to operate at the aerodrome. It is not intended to be used for determining the runway length or pavement strength requirements for aeroplanes or to specify a minimum or maximum length for a runway. In the discussion of aerodrome characteristics, reference will be made to the code elements where the learning objectives require it. Historically, questions have been asked in the exam concerning the code elements.

19.11 Elements. The code is composed of two elements which are related to aeroplane performance characteristics and dimensions. Element 1 is a number based on the aeroplane reference field length (see 19.2.3 below) and element 2 is a letter based on the aeroplane wing span and the outer main gear wheel span (the distance between the outside wheels of the undercarriage). A particular specification is related to the more appropriate of the two elements of the code or to an appropriate combination of the two code elements. The code letter or number selected for design purposes is related to the critical aeroplane characteristics for which the facility is provided. In aerodrome design and operations, the aeroplanes which the aerodrome is intended to serve are first identified and then the two elements of the code. The following table defines the aerodrome code.

Aerodrome Reference Code				
Code Element 1		Code Element 2		
Code Number	Aerodrome Reference Field Length	Code Letter	Wing Span	Outer Main Gear Wheel Span
1	Less than 800m	A	Up to but not including 15m	Up to but not including 4.5m
2	800m or more, but less than 1 200m	B	15m or more, but less than 24m	4.5m up to but not including 6m
3	1 200m or more, but less than 1 800m	C	24m or more, but less than 36m	6m up to but not including 9m
4	1 800m or more	D	36m or more, but less than 52m	9m up to but not including 14m
		E	52m or more, but less than 65m	9m up to but not including 14m
		F	65m up to but not including 80m	14m up to but not including 16m

Figure 19.2: Aerodrome reference code.

19.12 Aeroplane Reference Field Length. This is defined as the minimum field length (take off distance) required for take off at max certificated take off mass, at sea level, with standard atmospheric conditions, still air and runway slope, as shown in the appropriate AFM prescribed by the certifying authority or equivalent data from the aeroplane manufacturer.

GLOSSARY OF TERMS

19.13 Knowledge Requirement. The learning objectives require the student to be able to recall the definitions contained in the following table. Most of them will already be familiar and the remainder will be used in the ensuing discussions concerning aerodromes.

Term	Definition
Aerodrome	Any area of land or water designed, equipped, set apart or commonly used for affording facilities for the landing and departure of aircraft and includes any area or space, whether on the ground, on the roof of a building or elsewhere, which is designed, equipped or set apart for affording facilities for the landing and departure of aircraft capable of descending or climbing vertically, but shall not include any area the use of which for affording facilities for the landing and departure of aircraft has been abandoned and has not been resumed.
Aerodrome elevation	The elevation of the highest point of the landing area.
Aerodrome Reference point (ARP)	The geographical location of the aerodrome and the centre of its traffic zone where an ATZ is established.
Aircraft stand taxi lane	A portion of an apron designated as a taxiway and intended to provide access to aircraft stands only.
Apron taxiway	A portion of a taxiway system located on an apron and intended to provide a through taxi route across the apron.
Clearway	An area at the end of the take-off run available and under the control of the aerodrome licensee, selected or prepared as a suitable area over which an aircraft may make a portion of its initial climb to a specified height.
Crosswind component	The velocity component of the wind measured at or corrected to a height of 33 feet above ground level at right angles to the direction of take-off or landing.
Instrument approach runway	A runway intended for the operation of aircraft using non-visual aids providing at least directional guidance in azimuth adequate for a straight-in approach.
Instrument approach strip	An area of specified dimensions which encloses an instrument runway.
Landing area	That part of the manoeuvring area primarily intended for the landing or take-off of aircraft.
Main runway	The runway most used for take-off and landing.
Non-instrument (visual) runway	A runway intended for the operation of aircraft using visual approach procedures.
Obstacle	All fixed (whether temporary or permanent) and mobile objects, or parts thereof, that are located on an area intended for the surface movement of aircraft or that extend above a defined surface intended to protect aircraft in flight.

Obstacle Free Zone	A volume of airspace extending upwards and outwards from an inner portion of the strip to specified upper limits which is kept clear of all obstructions except for minor specified items.
Precision approach runway	A runway intended for the operation of aircraft using visual and non-visual aids providing guidance in both pitch and azimuth adequate for a straight-in approach. These runways are divided into three categories.
Rapid exit taxiway (High speed turn-off)	A taxiway connected to a runway at an acute angle and designed to allow landing aeroplanes to turn off at higher speeds than are achieved on other exit taxiways thereby minimising runway occupancy times.
Runway	A defined rectangular area, on a land aerodrome prepared for the landing and take-off run of aircraft along its length.
Runway End Safety Area (RESA)	An area defined about the extended runway centreline and adjacent to the end of the strip primarily intended to reduce the risk of damage to an aeroplane undershooting or overrunning the runway.
Shoulder	An area adjacent to the edge of a paved surface so prepared as to provide a transition between the pavement and the adjacent surface for aircraft running of the pavement.
Stop way	A defined rectangular area at the end of the take-off run available prepared and designated as suitable area in which an aircraft can be stopped in the case of a discontinued take-off.
Strip	An area of specified dimensions enclosing a runway and taxiway to provide for the safety of aircraft operations.
Take-off Runway	A runway equipped to allow take-offs in specified weather minima.
Taxiway	A defined path on a land aerodrome established for the taxiing of aircraft and intended to provide a link between one part of the aerodrome and another.
Taxiway holding position	A designated position at which taxiing aircraft and vehicles may be required to hold in order to provide adequate clearance from a runway.
Taxiway Intersection	A junction of two or more taxiways.
Threshold	The beginning of that portion of the runway usable for landing.
Usability	The percentage of occasions on which the crosswind component is below a specified value. The usability may be determined for any combination of take-off and landing directions available at an aerodrome.

AERODROME DATA

19.14 Aerodrome Reference Point (ARP). An aerodrome reference point must be established for an aerodrome. It is defined as the designated geographical (Lat and Long) location of the aerodrome and is to be reported to the aeronautical information services authority in degrees, minutes and seconds. The ARP should be located near the initial or planned geometric centre of the aerodrome and will normally remain where first established. In reality, it is usually the centre of the longest runway.

19.15 Pre-flight altimeter check location. One or more pre-flight altimeter check locations are required for an aerodrome. These should be located on an apron to enable an altimeter check to be made prior to obtaining taxi clearance and thus eliminate the need for stopping for that purpose after leaving the apron. Normally an entire apron can serve as a satisfactory altimeter check location. The elevation of a pre-flight altimeter check location is given as the average elevation, rounded to the nearest metre or foot, of the area in which it is located. The elevation of any portion of a pre-flight altimeter check location must be within 3m (10ft) of the average elevation for that location.

19.16 Aerodrome and Runway Elevations. The aerodrome elevation and geoid undulation at the aerodrome elevation position (the highest point of the landing area) is measured to the nearest half metre or foot. For precision runways, it is to be measured to the nearest 0.25m or foot. *Note:* The geoid is the gravitational level of mean sea level extending continuously through the continents. It is irregular due to local gravitational disturbances, hence geoid undulations.

19.17 Pavement strengths. Where paved areas (runways, taxiways, aprons) are used by aircraft with maximum take off mass greater than 5,700 kg, the strength of the pavement is reported by the aircraft classification number - pavement classification number (ACN-PCN) system. An aircraft can safely use a paved area if the PCN is equal to or greater than the ACN.

19.18 PCN. The Pavement Classification Number (PCN) is used to indicate the strength of a runway, taxiway or apron. It is of primary importance for the apron as this is where the aircraft mass will be greatest. PCN is only used for paved areas.

19.19 ACN. The Aircraft Classification Number (ACN) is a single unique number expressing the relative effect of an aircraft on a paved area relating to pavement type and thickness. It is a number on a continuous scale increasing from 0 with no upper limit. Each aircraft has an ACN.

19.20 Aircraft less than 5,700Kg. The strength of the pavement for use by aircraft with maximum mass equal to or less than 5,700kg is calculated from the maximum allowable mass or the maximum tyre pressure.

19.21 Declared distances. The following distances must be calculated to the nearest metre or foot for a runway intended for the use by international commercial air transport:

- Take-off run available (TORA);
- Take-off distance available (TODA);
- Accelerate-stop distance available (ASDA);
- Landing distance available (LDA).

19.22 TORA. Definition: The distance between the point at which an aeroplane can commence the take-off run to the nearest point in the direction of take off at which the surface is incapable of bearing the mass of the aeroplane under normal operating conditions.

19.23 TODA. Definition: The distance from the start of TORA to the nearest obstacle in the direction of take-off projecting above the surface of the aerodrome and capable of affecting the safety of an aeroplane in flight (up to a maximum distance of $1.5 \times \text{TORA}$). Usually, TODA is TORA plus clearway if a clearway exists.

19.24 ASDA. Definition: The distance from the start of the take-off run to the nearest point in the direction of take-off at which the aircraft cannot roll over the surface and be brought to rest in an emergency without risk of accident. ASDA used to be called EDA (Emergency Distance Available). Usually ASDA consists of TORA plus the stop way if available.

19.25 LDA. Definition: The distance from the point where an aeroplane can commence its landing to the point where the surface is incapable of bearing the mass of the aircraft under normal operating conditions. Usually this is the full length of the runway, but may include a paved stop way (if available) where the threshold is displaced.

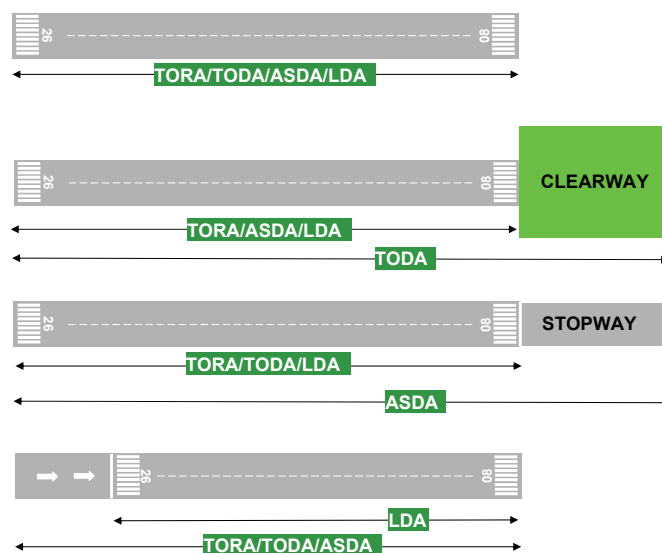

Figure 19.3: Declared distances.

19.26 Condition of the Movement Area and Related Facilities. Information on the condition of the movement area and the operational status of related facilities must be provided to the appropriate aeronautical information service units, and similar information of operational significance to the air traffic service units, to enable those units to provide the necessary information to arriving and departing aircraft. The information must be kept up to date and changes in conditions reported without delay. The condition of the movement area and the operational status of related facilities are to be monitored and reports on matters of operational significance or affecting aircraft performance given, particularly in respect of the following:

- Construction or maintenance work;
- Rough or broken surfaces on a runway, a taxiway or an apron;
- Snow, slush or ice on a runway, a taxiway or an apron;
- Water on a runway, a taxiway or an apron;
- Snow banks or drifts adjacent to a runway, a taxiway or an apron;
- Anti-icing or de-icing liquid chemicals on a runway or a taxiway;
- Other temporary hazards, including parked aircraft;
- Failure or irregular operation of part or all of the aerodrome visual aids; and
- Failure of the normal or secondary power supply.

RUNWAYS

19.27 General. Runways are the parts of the manoeuvring area used for take-off and landing of aircraft. Except in remote areas, runways will always be prepared and usually paved (concrete and tarmac). A runway should be straight and not have excessive slopes. It is usual to be able to use the 'concrete strip' in either direction hence one concrete strip will provide two runways. In all cases, runways require markings (painted on the surface) which will give the pilot indications about the use of the runway and also assist the pilot to land the aircraft. It is true to say that no two runways are identical, and part of the learning curve for a pilot new to an airline is to become familiar with the aerodromes and the runways used during the operation. At a controlled aerodrome, the runway 'belongs' to the aerodrome controller. The pilot will be given permission to enter; backtrack; cross; take-off from and land on a specified runway. The ATCO will always specify the runway and the pilot always reads back the runway designator in RTF communications. For instance: ATCO "G-AG clear take-off runway 01"; pilot "Clear take-off runway 01 G-AB". In issuing this instruction, the ATCO is 'lending' the pilot the runway and after use it is returned to the ATCO.

19.28 Usability. Many factors affect the orientation, position and number of runways at an aerodrome. One important consideration is the usability factor with regard to the wind, which could be affected by the alignment of the runway. The number and orientation of runways should be such that the usability factor of the aerodrome is not less than 95% for the aeroplanes that the aerodrome is intended to serve. It is normal practice to take off and land into wind.

19.29 Types of Runway. Runways are defined by the use to which the runway is put, rather than by physical characteristics. An 'airfield' (a defined area of grass on which runways may be marked out or the direction of landing is indicated) may have several or no defined runways, whereas an 'airport' (a point of entry or exit from a country by air) may have several defined paved runways. The types of operations carried out on or to a runway determine the runway type. The service provided, markings, signs, and physical characteristics of a runway are type dependant.

19.30 Visual Runway. A non - instrument (visual) runway is used where take-off and landing criteria are determined visually. The criteria are usually defined by reference to ground visibility or RVR, cloud ceiling and day/night considerations. The markings of the runway will clearly indicate this fact.

19.31 Instrument Runway. An instrument runway is one to which instrument departure and approach procedures are applied. For departing traffic, the instrument departure procedure will be defined in the form of a SID. For arriving traffic, instrument runways are sub-divided into:

- Precision runways (using ILS; GLS; MLS or PAR approaches)
- Non-precision (using VOR; NDB; SRA or ILS in azimuth only approaches)

19.32 Take Off Runway. A take-off runway is a runway that can be used only for take offs. This is usually due to terrain preventing an instrument approach or precluding a missed approach. A take-off runway is usually only in one direction (the reciprocal not being used).

19.33 Location of Runway Threshold. The threshold of a runway should normally be located at the extremity of a runway unless operational considerations justify the choice of another location. If the threshold is displaced from the beginning of the paved strip, the location of the threshold is shown by a transverse white stripe across the runway surface and arrows leading to the position of the threshold. Reasons for displacing a threshold may include unserviceable runway conditions, RESA, radio altimeter operating area, glide path angle, obstacle clearance etc...

19.34 Length of Runways. The actual length of a runway should be adequate to meet the operational requirements of the aeroplanes for which the runway is intended and should be not less than the longest length calculated to correct for local conditions (elevation, temperature, runway slope, humidity and surface characteristics). There is no requirement to cater for the worst case aeroplane at critical mass. Where a secondary runway is constructed, the length criteria are applied in order to obtain a usability factor of 95%. Runway length is reported in metres, however, fixed distance markers (distance to go signs) along the edge of runways are in 1000s of ft but are defined in terms of 300m starting 300m from the threshold. For a 'concrete strip' to accommodate instrument approaches from either end it must be at least 1,800m between thresholds.

19.35 Width of Runways. Clearly, the width of a runway should not be less than that required for the aeroplanes using the aerodrome. During the construction of an aerodrome this can be easily achieved but with the introduction of big aeroplanes (i.e. the A380) previously acceptable runways may be rendered inadequate. The primary factors in deciding the width of a runway are wing span and outer main gear wheel span. The table below specifies the width of runways in terms of the aerodrome reference code:

Width of Runways						
Code number	Code letter					
	A	B	C	D	E	F
1(a)	18m	18m	23m	-	-	-
2(a)	23m	23m	30m	-	-	-
3	30m	30m	30m	45m	-	-
4	-	-	45m	45m	45m	60m
Note:(a): For a precision runway, w = 30 m where code is 1 and 2						

Figure 19.4: Width of runways.

19.36 Runway Strips. A runway strip is defined as an area including the runway, and stop way if provided, in which obstacles are kept to a minimum. Any that are there must be constructed so as to present the minimum danger to aircraft, in other words, they must be frangible (collapse upon impact). The purpose of the runway strip is to reduce the risk of damage to aircraft running off a runway, and to protect aircraft flying over it during take-off or landing operations.

19.37 Length of Runway Strips. A runway strip should extend before the threshold and beyond the end of the runway or stop way for a distance of at least:

- 60m where the code number is 2, 3 or 4;
- 60m for a code 1 instrument runway; and
- 30m for a code 1 non-instrument runway.

19.38 Width of Runway Strips. A runway strip, wherever practicable, is to extend laterally on each side of the centre line of the runway and its extended centre line, throughout the length of the runway strip, to a distance defined in the table below.

Width of Runway Strip				
Type of Runway	Runway code number			
	1	2	3	4
Precision	75m	75m	150m	150m
Non-precision	75m	75m	150m	150m
Non instrument	30m	40m	75m	75m

Figure 19.5: Width of runway strips.

19.39 Grading of Runway Strips. That portion of a strip of an instrument runway within a distance of at least 75m where the code number is at 3 or 4, and 40m where the code number is 1 or 2, from the centre line of the runway and its extended centre line, should provide a graded area for aeroplanes which the runway is intended to serve in the event of an aeroplane running off the runway. The surface of that portion of a strip that abuts a runway, shoulder or stopway must be flush with the surface of the runway, shoulder or stopway.

19.40 Objects on a Runway Strip. No fixed objects other than visual aids (PAPIs) are permitted on a runway strip within 77.5 m of the centre line for code 4F precision CAT I/II/III runways (60 m code 3 or 4 precision CAT I/II/III runways; or 45 m code 1 or 2 CAT I). No mobile objects are permitted on this part of a runway strip during landing or take off. An object which is situated within the stated dimensions is to be regarded as an obstacle and, as far as is practicable, removed.

19.41 Runway End Safety Area (RESA). This is an area of land usually at each end of a runway strip either side of the extended centreline which doesn't form part of the runway for operational (performance or planning) purposes, which is free from obstructions and set aside in case an aeroplane overshoots/overruns the end of the runway. It is primarily intended to reduce the risk of damage to the aeroplane. RESAs should be provided for all code 3 and 4 runways and for code 1 and 2 instrument runways. The RESA should be at least twice the width of the runway and extend from the end of the runway strip for a distance not less than 90m. However, for a code 3 or 4 runway it is recommended to extend for 240 m, and for 120 m for code 1 and 2.

Runway Strip – Code 4

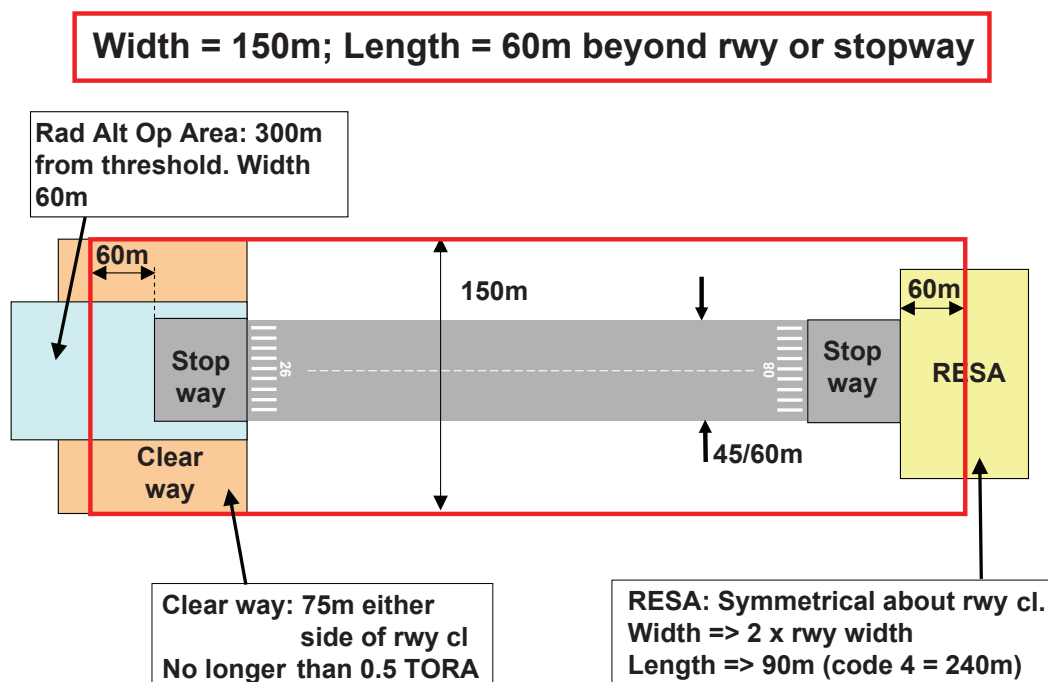

Figure 19.6: Runway strip - Code 4.

19.42 Clearways. This is a defined rectangular area on the ground under the control of the appropriate authority, selected or prepared as a suitable area over which an aeroplane may make a portion of its initial climb to a specified height. The origin of a clearway should be at the end of the take-off run available (TORA). The length should not exceed half the length of TORA, and the width should extend laterally to a distance of at least 75m on each side of the extended centre line of the runway.

19.43 Stopways. A stopway is a defined rectangular area on the ground at the end of take-off run available (TORA), prepared as a suitable area in which an aircraft can be stopped in the case of an abandoned/rejected take-off. It is to have the same width as the runway with which it is associated.

19.44 Radio Altimeter Operating Area. The radio altimeter operating area should be established in the pre-threshold area of a precision approach runway. For CAT II/III operations the use of rad alt is mandatory to determine DH. For CATII the minimum DH is 100ft (system minima) and for a 300ft/nm glide path this point would be at 600m (1/3 nm) from the aiming point. Usually the aiming point is 300m down the runway beyond the threshold; therefore the DH point would be 300m before the threshold. For CATIII the DH is less than 50ft, so a rad alt operating area for CATII would be suitable for CATIII also. The area should extend before the threshold for a distance of at least 300m. The area should extend laterally, on each side of the extended centre line of the runway; to a distance of 60m, except that when special circumstances so warrant, the distance may be reduced to no less than 30m if an aeronautical study indicates that such reduction would not affect the safety of operations of aircraft. The surface of the rad alt operating area should be level with no undulations of more than 7%.

TAXIWAYS

19.45 Introduction. A major limitation to the use of an aerodrome is the capability of the taxiways to accommodate different sizes of aeroplanes. Clearly, a narrow taxiway cannot cope with a large aeroplane. However, width is not the only consideration. The strength of a taxiway needs to be equal to that of the runway and the surface of taxiways is more vulnerable to damage than a runway (constant loading and unloading, turning and stopping). Taxiways may include turns especially close to runways. Taxiways may cross, join, intersect and require signs and markings to enable pilots to reach their destination on the aerodrome. Taxiways, especially parallel to runways, must not be confused with runways. At some aerodromes, Gatwick for example, the parallel taxiway is also the secondary runway! Considerations have to be given to the points on taxiways where aeroplanes are held prior to entering the runway for take-off, and also portions of taxiways close to the runway where the presence of a large aeroplane (a large lump of electromagnetically friendly metal) may interfere with ILS or MLS transmissions, or more fundamentally, is an obstacle to operations. In basic terms according to Annex 14, taxiways should be provided to permit the safe and expeditious surface movement of aircraft.

19.46 General layout. Sufficient entrance and exit taxiways for a runway are to be provided to expedite to movement of aeroplanes to and from the runway including the provision of rapid exit taxiways (fast turn off lanes) where traffic volumes are high. Where the end of a runway is not served by a taxiway, it may be necessary to provide additional pavement at the end of the runway for turning aeroplanes. Such areas may be usefully situated along the runway to reduce taxi times.

19.47 Taxiing of Aeroplanes. Taxiways are required to have a painted centreline which may be lit if the aerodrome is to be used at night. When taxiing an aeroplane it is vitally important that the nose wheel of the aeroplane is kept on the centreline especially during turns. Pilots usually gain this skill by experience but special procedures may be used in extreme cases i.e. Concorde where the nose wheel was so far aft of the nose of the aeroplane that pilots used marks on the windscreens to 'fix' the taxiway edge thus keeping the nose wheel in position on the centre line.

19.48 Rapid Exit Taxiways. Rapid exit taxiways, commonly called 'fast turn off lanes', are provided where traffic density is high. They are used to allow aeroplanes to turn off of the duty runway at a speed higher than would be permitted at a right angle turn on to a normal taxiway. They are located along runways and are designed and constructed to cater for turn off speeds of 93 km/h (50 kts) for code 3 or 4 runways and 65 km/h (35 kts) on code 1 and 2 runways, in wet conditions. Operators will specify the maximum speed for dry runway/taxiway operations. The taxiway is to include a straight section after the turn off curve to allow an exiting aircraft to come to a full stop clear of the intersecting taxiway. The intersecting angle with the runway should not be greater than 45°; not less than 25°; and preferably 30°.

19.49 Minimum Requirements. As previously mentioned, width is the most important factor in taxiway design and construction. The table below specifies the minimum requirements for clearance of the outermost main wheels when the nose wheel is on the centre line of the taxiway. The shoulders of taxiways which are used by turbine aeroplanes are to be prepared to prevent erosion by jet blast, and the ingestion of surface material into the jet engines. Taxiway strips, similar to runway strips, are provided primarily to delineate the area to be cleared of objects which may be obstacles. In the table, wheel base refers to the distance from the front of the nose wheel to the trailing edge of the main gear. Wheel to edge clearance refers to the distance from the outer edge of the main gear tyres to the defined edge of the taxiway.

Wheel to Taxiway Edge Clearance	
Code Letter	Clearance
A	1.5m
B	2.25m
C	3m if the taxiway is intended to be used by aeroplanes with wheel base less than 18m; otherwise 4.5m
D	4.5m
E	4.5m
F	4.5m

Figure 19.7: Wheel to edge clearance.

19.50 Width of taxiways. The straight portion of a taxiway should have a width of not less than that specified in the table below.

Taxiway Width	
Code Letter	
A	7.5m
B	10.5m
C	15 m if the taxiway is intended to be used by aeroplanes with a wheel base less than 18 m; otherwise 18 m
D	18 m if the taxiway is intended to be used by aeroplanes with an outer main gear span of less than 9 m; otherwise 23 m
E	23m
F	25m

Figure 19.8: Width of taxiways.

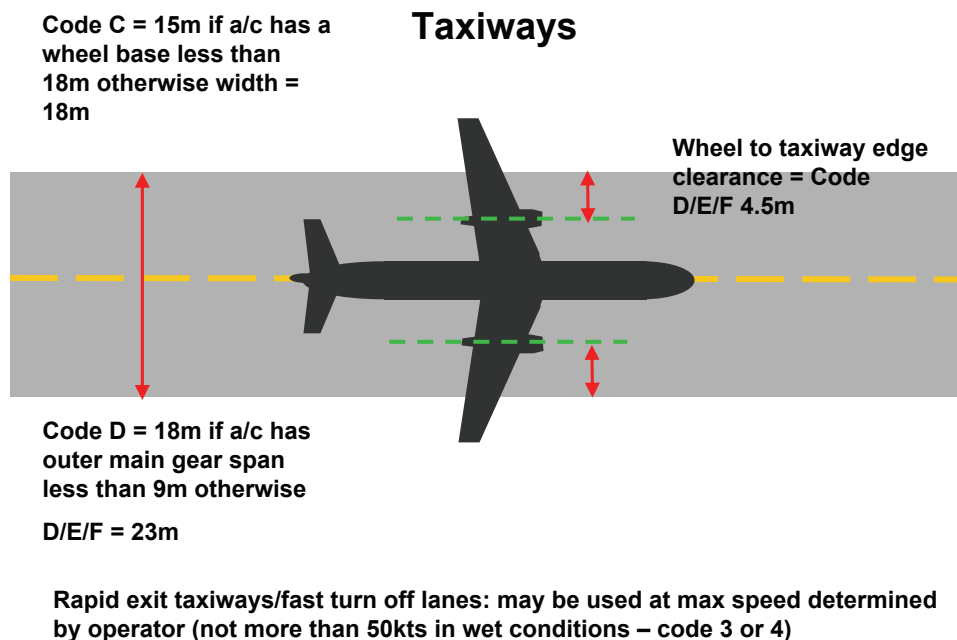

Figure 19.9: Taxiways.

19.51 Taxiway curves. Changes in direction of taxiways should be as few and small as possible. The radii of the curves should be compatible with the manoeuvring capability and normal taxiing speeds of the aeroplanes for which the taxiway is intended. An example of widening taxiways to achieve the wheel clearance specified is illustrated below.

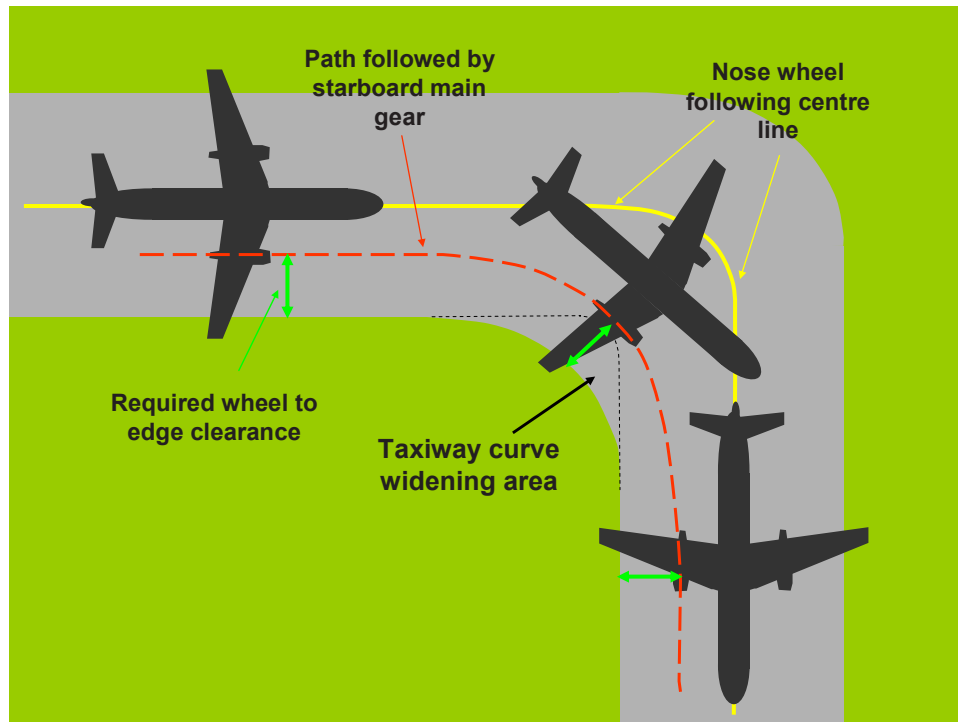

Figure 19.10: Taxiway curves.

19.52 Holding bays and Runway-Holding Positions. Inevitably, at a busy aerodrome, aeroplanes will be required to wait their turn for take off. It is common to see a stream of traffic waiting along the taxiway for take off, but at an international airport the queues for take off can exceed the capability of the taxiway to accommodate all the aircraft waiting. In this situation or where environmental considerations exist, holding bays are provided adjacent to runway entrances which leave the taxiways clear. At some major aerodromes with particularly high traffic levels or intense peaks in traffic density, 'sin bins' are established to take aeroplanes out of the stream if something has gone wrong. Regardless of the position of holding bays, the entrance to the runway will be protected by a defined mandatory holding point set back from the edge of the runway to accommodate all the traffic using the runway. A runway-holding position must be established on a taxiway if the location or alignment of the taxiway is such that a taxiing aircraft or vehicle can infringe an obstacle limitation surface or interfere with the operation of radio navigation aids (ILS or MLS). The method of indicating a runway-holding position is covered later in the notes (under Signs and Markings). A runway-holding position, or positions, must be established at the distances in the table on page 383 at an intersection of a taxiway with a runway; and an intersection of a runway with another runway when the former runway is part of a standard taxi-route.

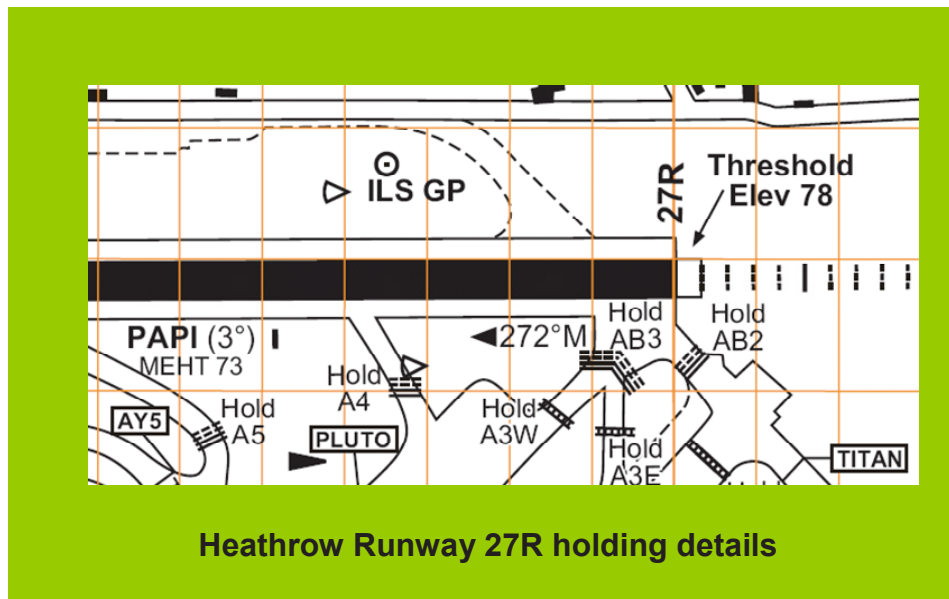

Figure 19.11: Holding points.

Runway Holding Point Positions (Distance from Centre Line of Runway)				
Type of Runway	Runway code number			
	1	2	3	4
Take-off	30m	40m	75m	75m
Non instrument (Visual)	30m	40m	75m	75m
Non-precision Instrument	40m	40m	75m	75m
Precision CAT I	60m(b)	60m(b)	90m(a,b)	90m(a,b,c)
Precision CAT II/III	-	-	90m(a,b)	90m(a,b,c)
<p><i>Notes:</i></p> <ul style="list-style-type: none"> a. May be increased if holding elevation lower than runway b. May be increased to avoid interference with radio navigation aids c. For code F this should be 107.5 m 				

Figure 19.12: Minimum distances from runway centre lines of holding positions.



Figure 19.13: A "line-up" at Manchester for rwy 06L.

19.53 Road holding position. This is a designated position at which vehicles may be required to stop and wait where the taxiway is also used as a road for aerodrome vehicular traffic. Normally, a road holding point will have traffic lights. A road holding position must be established at an intersection of a road with a runway. The distances in the table on page 383 apply to road holding points.

APRONS

19.54 Requirement. Aprons are provided where necessary to permit the embarking and disembarking of passengers and the loading and off loading of cargo and mail, as well as the servicing of aircraft, without interference with aerodrome traffic. The total apron area should be adequate to permit the expeditious handling of the aerodrome traffic at its maximum anticipated density. Aprons are to be built to accommodate slow moving traffic and in any case to withstand higher stresses than runways. Aircraft parking areas on aprons (stands) are to be marked and are required to provide a minimum distance between parked aircraft. For code A the distance is 3m, and for code D and above 7.5m.

19.55 Isolated Aircraft Parking Position. An isolated aircraft parking position is to be designated, or the control tower advised of an areas or areas, suitable for the parking of an aircraft which is known or believed to be the subject of unlawful interference, or which for other reasons needs isolation from normal aerodrome traffic. This special area is not to be less than 100m from any other parking area, building, or public area, or over underground utilities (gas, aviation fuel, electrical or communications cables).

QUESTIONS

1. Aerodrome reference code 4 refers to field length of:
 - a. 900 m.
 - b. 1000 m.
 - c. 1600 m.
 - d. 1800 m or more.

2. The signal area should be located so that it is visible from the air. A lack of a signal area denotes that:
 - a. non-radio traffic will not be accepted at the aerodrome other than emergency traffic.
 - b. non-radio traffic will be accepted.
 - c. non-radio traffic will be accepted in daylight hours only.
 - d. non-radio traffic will not be accepted in daylight hours only.

3. The Aerodrome Reference Code consists of Code Element 1 (aeroplane reference field length) and Code Element 2. What does Code Element 2 define?
 - a. Wing span and inner main gear wheel span.
 - b. Fuselage width and inner main gear wheel span.
 - c. Fuselage width and outer main gear wheel span.
 - d. Wing span and outer main gear wheel span.

4. A radio altimeter operating area must extend before the threshold of a precision approach runway for a distance of at least:
 - a. 100 metres.
 - b. 200 metres.
 - c. 300 metres.
 - d. 500 metres.

5. Which of the following is a valid aerodrome reference code?
 - a. 6B.
 - b. 4G.
 - c. 7G.
 - d. 2B.

6. What is a stopway for?
 - a. Stopping after landing distance.
 - b. Extending the Landing Distance Available.
 - c. Stopping after a rejected take off.
 - d. A runway extension for big aircraft.

7. A transverse white stripe on a runway is associated with a:
 - a. closed runway.
 - b. a runway which is 2400 meters or longer.
 - c. displaced threshold.
 - d. a runway available for circling to land approaches.

8. Which "code letter" identifies a taxiway that has to be used by an aircraft with a wheel-base of 15 metres?
- Code letter E .
 - Code letter C.
 - Code letter B.
 - Code letter D.
9. According to the Aerodrome Reference Code, the code letter E relates to an aircraft wingspan of:
- 15m or more but less than 24m.
 - 36m or more but less than 52m.
 - 52m or more but less than 65m.
 - 24m or more but less than 36m.
10. The stopway is a defined rectangular area on the ground at the end of the take-off run available which is prepared as a suitable area:
- to stop an aircraft after a rejected take-off.
 - to stop a landing aircraft in case of an emergency.
 - to stop a starting or landing aircraft.
 - to stop a landing aircraft if it overshoots the runway.
11. An area defined about the extended runway centreline and adjacent to the end of the strip, primarily intended to reduce the risk of damage to an aircraft undershooting or overrunning the runway is defined as a:
- clearway.
 - runway strip extension.
 - runway end safety area.
 - altimeter operating area extension.
12. What is the width of a code letter D taxiway used by aircraft with an outer main gear wheel span of less than 9m?
- 10.5m.
 - 15m.
 - 18m.
 - 23m.
13. What is the minimum width of a code 4 runway?
- 18m.
 - 23m.
 - 30m.
 - 45m.
14. When a fixed distance marking has to be provided this marking shall commence at:
- 150m from the threshold.
 - 300m from the threshold.
 - 150m from the aiming point.
 - 300m from the aiming point.

15. TODA consists of:
- a. TORA but excluding the clearway.
 - b. TORA and includes the clearway.
 - c. TORA but excluding the stopway.
 - d. TORA only.

ANSWERS

Question	Answer	Reference
1.	D	19.10
2.	A	6.83 / 19.5
3.	D	19.11
4.	C	19.44
5.	D	19.10
6.	C	19.43
7.	C	19.33
8.	B	19.50
9.	C	19.10
10.	A	19.43
11.	C	19.41
12.	C	19.50
13.	D	19.35
14.	B	19.34
15.	B	19.23

CHAPTER TWENTY

AERODROMES VISUAL AIDS MARKINGS AND SIGNS

Contents

REQUIREMENTS	365
VISUAL AIDS FOR NAVIGATION	365
RUNWAY MARKINGS	366
TAXIWAY MARKINGS.	371
SIGNS	376
MARKERS.	382
VISUAL DOCKING GUIDANCE SYSTEMS	384
QUESTIONS	386
ANSWERS	388

REQUIREMENTS

20.1 Background. The complex nature of aerodromes coupled with the fact that no two aerodromes have the same layout, operations and geographic position, makes standardisation in the provision of visual information to pilots taxiing aircraft and preparing for landing or take-off, essential. Annex 14 specifies the applicable SARPS and the learning objectives are specific in requiring the student to have more than just a theoretical understanding of the subject. The discussion is broken down into three sections dealing with visual aids for navigation; aerodrome markings, and aerodrome signage. It must be born in mind that whilst the SARPS are adopted by all contracting states, there may be differences and there may some signs for instance, seen at foreign aerodromes that are not seen on a UK aerodrome and vice versa.

VISUAL AIDS FOR NAVIGATION

20.2 Indicators and Signalling Devices. Aerodromes are required to be equipped with a means of indicating the wind direction to pilots of non-radio aircraft. Remember, the Rules of the Air require a pilot to land and take off into wind, so there must be a method of indication. In order for a non-radio pilot to know what the landing direction is, a landing indicator is required. Also a means of communicating visual signal to non-radio aircraft is required to be positioned in the visual control room.

20.3 Wind Direction Indicators. An aerodrome must be equipped with at least one wind direction indicator (commonly called a 'wind sock'). The wind direction indicator should be in the form of a truncated cone made of fabric and should have a length of not less than 3.6m and a diameter, at the larger end, of not less than 0.9m. It should be constructed so that it gives a clear indication of the direction of the surface wind and a general indication of the wind speed. The colour or colours should be so selected as to make the wind direction indicator clearly visible and understandable from a height of at least 300m, having regard to background. Where practicable, a single colour, preferably white or orange, should be used. The location of at least one wind direction indicator (the 'master' wind sock) should be marked by a circular white band 15m in diameter and 1.2m wide. Provisions should be made for illuminating at least one wind indicator at an aerodrome intended for use at night.

20.4 Landing Direction Indicator. When provided, a landing direction indicator shall be located in a conspicuous place on the aerodrome. If a signal square is provided a landing "T" will always be included in the signs in the square. The landing direction indicator should be in the form of a "T". The colour of the "T" should be either white or orange, the choice being dependent on the colour that contrasts best with the background against which the indicator will be viewed. Where required for use at night the landing "T" is to be either illuminated or outlined by white lights.

20.5 Signalling Lamp. A signalling lamp must be provided at a controlled aerodrome in the aerodrome control tower for the purpose of showing the light signals to aircraft either in the air or on the ground as defined in chapter 6. The lamp, usually an Aldis lamp specially designed for signalling, must be capable of producing red, green and white light and of being aimed manually at any target as required; giving a signal in any one colour followed by a signal in either of the other two colours; and being operated to transmit a message in any one of the three colours by Morse code up to a speed of at least four words per minute. The VCR should also be equipped with the means of 'firing' pyrotechnic signals again as required in chapter 6.

20.6 Signal Panels and Signal Area. The provision of a signals area ('signals square') at an aerodrome implies that non-radio traffic is accepted. A signals area is not required if an aerodrome authority has proscribed routine non-radio traffic (the aerodrome would still be required to provide a service to an aircraft suffering a communications failure that has indicated the intention to land). The signals area should be located so as to be visible for all angles of azimuth above an angle of 10° above the horizontal when viewed from a height of 300m. The signal area shall be an even horizontal surface of at least 9m square. The colour of the signal area should be chosen to contrast with the colours of the signal panels used, and it should be surrounded by a white border not less than 0.3m wide. It is normal for the signals area to be positioned in front (on the aerodrome side) of the control tower/VCR. The signals that may be displayed in the signals area are covered in chapter 6.

RUNWAY MARKINGS

20.7 General. Markings are characters; numbers and shapes painted on the concrete surfaces of the aerodrome. Markings are found on runways, taxiways and aprons. Markings may either give location or directional information or indicate a mandatory requirement i.e. to stop. The colour of a marking is dependent upon where it is used and the size must be sufficient for it to be read or understood easily from the flight deck of an aeroplane. The ICAO standard is for runway markings to be white and taxiway markings to be yellow.

20.8 Runway Markings. Runway markings are white. It has been found that, on runway surfaces of light colour, the conspicuity of white markings can be improved by outlining them in black. Large areas of paint can create a friction problem; therefore this should be reduced, as far as practicable, by the use of a suitable kind of paint. Markings may consist of numbers and letters; solid areas, or a series of longitudinal stripes providing an effect equivalent to the solid areas. Generally, runway markings assist the pilot with locating the threshold, identifying the runway, defining the centreline and locating the aiming point. Additionally for an instrument runway, as well as the aiming point, it will have touchdown zone markings.



Figure 20.1: Runway markings at RAF Brize Norton.

20.9 Runway Designation Marking. A runway designation marking is to be provided at the threshold of paved runways, and as far as is practicable at the threshold of unpaved (grass) runways. If the runway threshold is displaced from the extremity of the runway, a sign showing the designation of the runway may be provided for aeroplanes taking off.

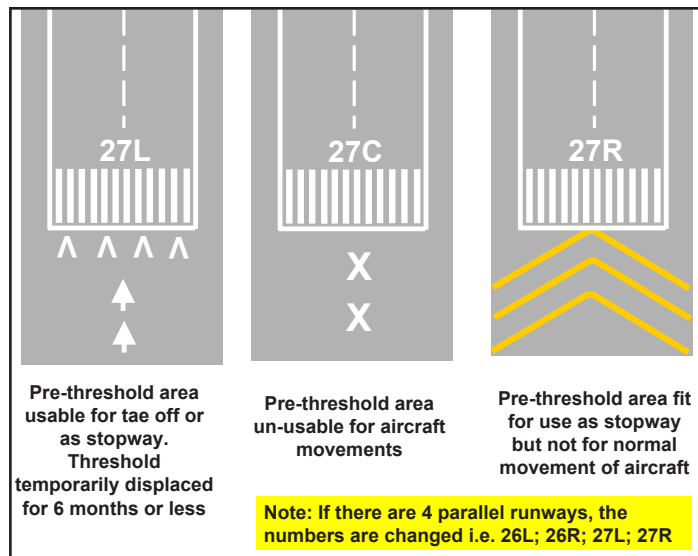

Figure 20.2: Runway designation markings.

20.10 Characteristics. A runway designation marking should consist of a two digit number and on parallel runways shall be supplemented with a letter. On a single runway, dual parallel runways and triple parallel runways the two digit number shall be the whole number nearest the magnetic bearing (QDM) divided by 10 ($094 \div 10 = 09.4$ rounded down to 09) of the runway when viewed from the direction of approach. On four or more parallel runways, one set of adjacent runways shall be numbered to the nearest one tenth QDM and the other set of adjacent runways numbered to the next nearest one tenth of the QDM. When the above rule would give a single digit number, it shall be preceded by a zero. In some states the '0' is omitted i.e. at New York JFK the south to north runways are '4R' and '4L'. In the case of parallel runways, each runway designation number shall be supplemented by a letter as follows, in the order shown from left to right when viewed from the direction of approach:

- For two parallel runways "09L" "09R";
- For three parallel runways "09L" "09C" "09R";
- For four parallel runways "09L" "09R" "10L" "10R" (in this case the QDM for one pair will be increased to differentiate that pair from the other).

20.11 Runway Centre Line Marking. A runway centre line marking is required on a paved runway. The centre line marking is painted along the centre line of the runway between the runway designation markings.

20.12 Characteristics. A runway centre line marking consists of a line of uniformly spaced stripes and gaps. The length of a stripe plus a gap shall be not less than 50m or more than 75m. The length of each stripe shall be at least equal to the length of the gap or 30m, whichever is greater.

20.13 Threshold Marking. The threshold of a runway is either the beginning of the marked out grass area, or the start of the concrete strip. A threshold marking is required to be provided at the thresholds of paved instrument runways, and of paved non-instrument code 3 and 4 runways and the runway is intended for use by international commercial air transport. A threshold marking should be provided, as far as is practicable, at the threshold of an unpaved runway.

20.14 Location. The stripes (commonly known as 'piano keys') of the threshold marking, should start 6m from the threshold.

20.15 Characteristics. A runway threshold marking is a pattern of longitudinal stripes of uniform dimensions disposed symmetrically about the centre line of the runway. For a runway width of 45m (for non-precision approach and non-instrument runways 45m or greater in width; they may be placed either side of the runway designation number). The stripes should extend laterally to within 3m of the edge of the runway or to a distance of 27m on either side of a runway centre line, whichever results in the smaller lateral distance. Where a runway designation marking is placed within a threshold marking there will be a minimum of three stripes on each side of the centre line of the runway. Where a runway designation marking is placed above a threshold marking the stripes shall be continued across the runway. The stripes shall be at least 30m long and approximately 1.80m between them except where the stripes are continued across a runway, in which case a double spacing shall be used to separate the two stripes nearest the centre line of the runway. In the case where the designation marking is included within the threshold marking this spacing shall be 22.5m. The number of stripes shall be in accordance with the runway width as follows:

Runway Threshold Markings	
Runway Width	Number of Stripes
18m	4
23m	6
30m	8
45m	12
60m or more	16



Figure 20.3: Runway threshold markings.

20.16 Transverse stripe. Where a threshold is displaced from the extremity of a runway (the end of the concrete) or where the end is not at right angles to the runway centre line, a transverse stripe should be added to the threshold marking. When a runway threshold is permanently displaced, arrows shall be provided on the portion of the runway before the displaced threshold. The reasons why a threshold may be displaced have been discussed in chapter 19.

20.17 Aiming Point Marking. The aiming point marking indicates the position of the origin of the visual glide slope (PAPI) and the ILS GP transmitter. An aiming point marking is to be provided at each approach end of code 2,3 or 4 paved instrument runways. It is recommended that an aiming point marking is provided on code 1 paved instrument runways and code 3 or 4 paved non- instrument runways when additional conspicuity of the aiming point is desirable. An ICAO specification aiming point marking consists of two conspicuous stripes whereas a UK CAA aiming point marking is more complex as can be seen on the photograph of RAF Brize Norton, see paragraph 20.9.

20.18 Location. The aiming point marking shall commence no closer to the threshold than the distance indicated in the appropriate column of table 20.3.6.1, except that on a runway equipped with a visual approach slope indicator system (PAPI or VASI); the beginning of the marking shall be coincident with the visual approach slope origin. For a code 4 runway less than 2400m long, the aiming point is positioned 300m from the threshold. For a normal 3° glide path (300ft/nm), the aircraft on glide path will cross the threshold at a height of 50ft. Bigger aircraft require longer LDA so for runways 2400m or more in length have the aiming point 400m from the threshold so the aircraft crosses the threshold at 67ft thus giving additional gear to concrete clearance.

Aiming Point Marking Location	
Landing Distance Available (LDA)	Threshold to Beginning of Marking
Less than 800m	150m
800m up to but not including 1200m	250m
1200m up to but not including 2400m	300m
2400m or more	400m

Figure 20.4: Location of aiming point marking.

20.19 Touchdown Zone Markings. Touchdown zone (TDZ) markings indicate the area of the runway where the aeroplane should be landed. Landing Distance Available is an operational consideration for the use of a runway, but it is not common practice to land the aeroplane on the threshold marking. The TDZ markings give the pilot an indication of extent of the useable touchdown area and if distance coded, the length of the touchdown zone remaining. Markings are required for code 2, 3 and 4 paved precision approach runways, and recommended for code 3 or 4 paved non-precision or non-instrument runways, where additional conspicuity is required.

20.20 Location. TDZ markings consist of pairs of rectangular markings symmetrically placed about the runway centre line with the number of pairs related to the landing distance available. For code 4 runways (1 800m or more in length) the TDZ markings have 6 pairs.

20.21 Characteristics. Touchdown zone markings conform to either of the two patterns shown in below. Pattern "A" is the basic marking system whereas pattern "B" is distance coded. The choice of patterns is not runway length dependant. The pairs of markings have longitudinal spacing of 150 m beginning from the threshold. If a pair of TDZ markings is coincident with or located within 50m of an aiming point marking, the TDZ marking at that position is deleted from the pattern.



Figure 20.5a: Pattern "A", basic plain markings.



Figure 20.5b: Pattern "B", distance coded.

20.22 Runway Side Stripe Marking. Runway side stripe markings are to be provided between the thresholds of precision runways, and paved runways where there is a lack of contrast between the runway edges and the shoulders or the surrounding terrain. It is recommended that side stripes are marked on all precision runways regardless of the contrast with the surrounding ground. The picture of the runway at Gran Canaria, on the previous page shows the use of side stripes.

TAXIWAY MARKINGS.

20.23 Requirements. Taxiway markings and aircraft stand markings are yellow. If there is a need to enhance conspicuity, the lines may be outlined in black.

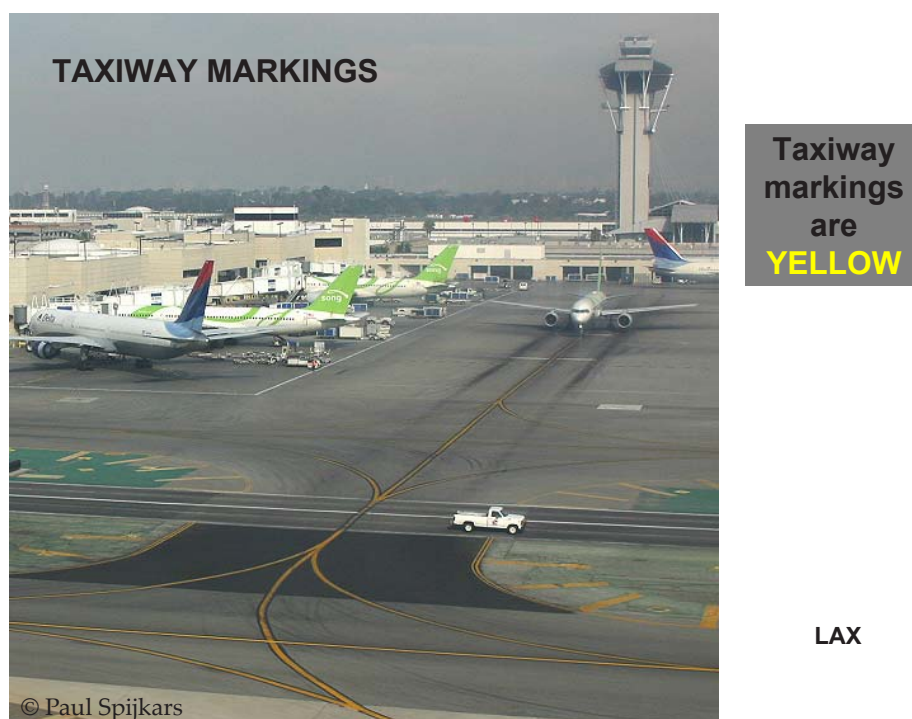

Figure 20.6: Taxiway markings.

20.24 Apron Safety Lines. Although not strictly taxiway markings, in the apron areas the safe movement of aircraft into and out of parking stands can be enhanced by the use of apron safety lines. If all ground equipment and vehicles are parked or positioned behind the apron safety lines a pilot or a marshaller can ignore the presence of those obstacles when parking aircraft. Apron safety lines are to be of a conspicuous colour which shall contrast with that used for aircraft stand markings.

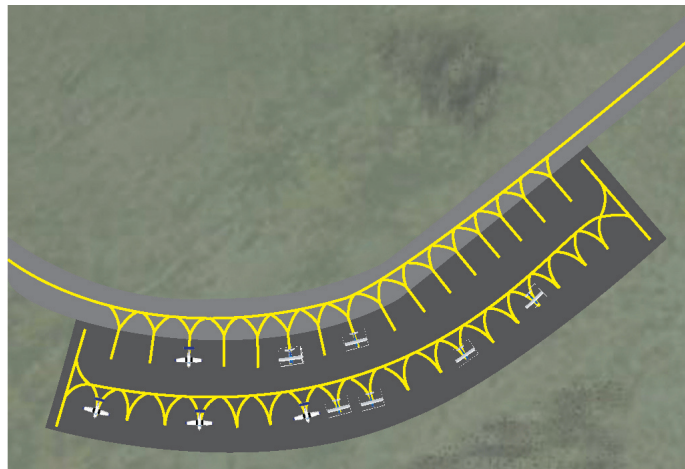

Figure 20.7: Taxiway centre line marking.

20.25 Taxiway Centre Line Marking. Taxiway centre line marking are to be provided on a paved taxiway, de/anti-icing facility and the apron areas where the code number is 3 or 4 (and recommended for code 1 and 2). Centreline markings are to give guidance from the runway centre line, to the point on the apron where aircraft stand markings commence. Taxiway centre line marking are also provided on a paved runway when the runway is part of a standard taxi-route and there is no runway centre line marking; or where the taxiway centre line is not coincident with the runway centre line.

20.26 Runway-Holding Position Marking. Holding points are established at the entrance to all runways. It is not uncommon for there to be more than one holding point at the entrance to a runway. A runway-holding position marking is to be displayed at a runway-holding point. The actual holding position is indicated by the mandatory sign (see signs later in this chapter) which will be displayed on at least, the left hand side of the taxiway as the aeroplane approaches the runway. Ideally the sign should be on both sides of the taxiway. The marking is to extend all the way across the taxiway. The position may be augmented by stop bars or runway guard lights, see paragraph 21.32. The distance between a runway-holding position and the centre line of the associated runway is specified in the picture after paragraph 19.52 and in the case of a precision approach runway, will be such that a holding aircraft (or vehicle) will not interfere with the operation of radio navigation aids, specifically ILS. A runway holding point may also be established where the approach to a runway passes over a taxiway to another runway. In this case, the associated sign will specify what the holding point is for.

20.27 Patterns. There are two distinct patterns for runway-holding markings. These are defined as 'Pattern A' and 'Pattern B'.

20.28 Pattern A. The closest holding point to a runway will always be marked with a Pattern A marking, and it will be positioned at an intersection of a taxiway and a non-instrument (visual) runway, a non-precision approach runway or a take-off runway. Where a single taxi-holding position is provided at an intersection of a taxiway and a precision approach category I, II or III runway, the taxi-holding position marking shall be Pattern A. For a code 4 runway, the Pattern A holding point will be no closer than 75m to the centreline of the runway.

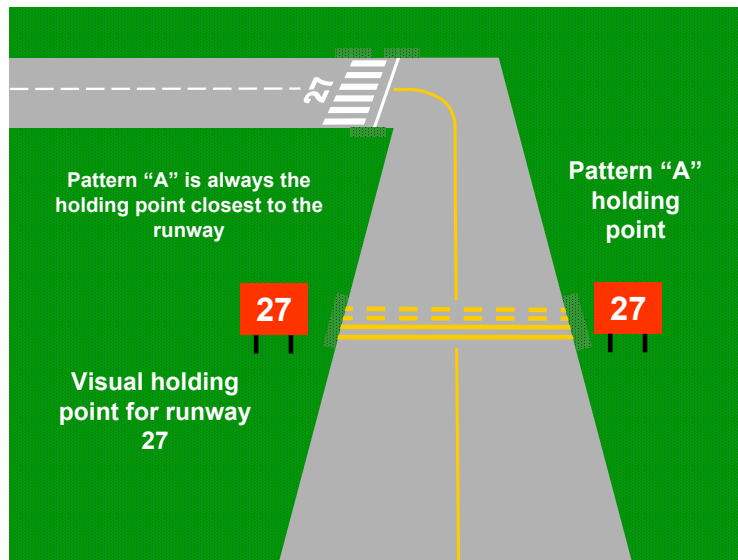

Figure 20.8: Runway-holding markings, pattern A.

20.29 Pattern B. Where two or three taxi-holding positions are provided at such an intersection, the taxi-holding position marking closer (closest) to the runway shall be as shown in pattern A and the markings further from the runway shall be pattern B. Any other holding point associated with a runway required on a taxiway will also be Pattern B.

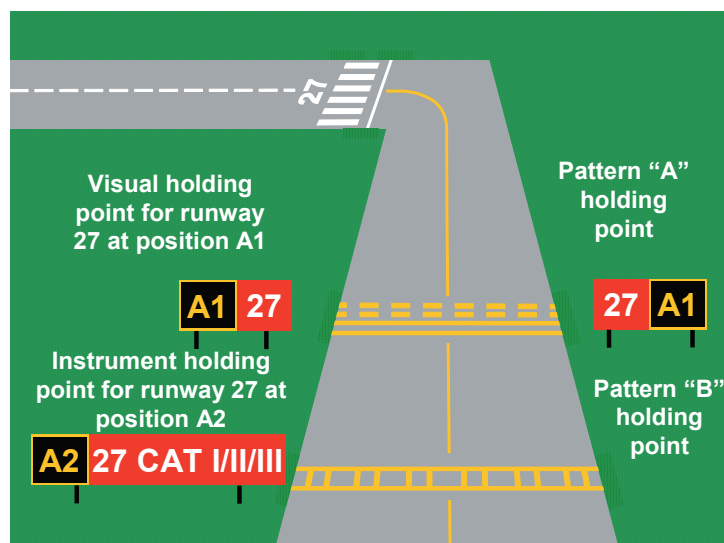

Figure 20.9: Runway-holding markings, pattern B.

20.30 Intermediate Holding Position Marking. Where two (or more) taxiways cross, holding points are established at suitable distances from the crossing taxiway. It may be that one taxiway has priority and the holding point marking may be augmented by a mandatory marking. It should be coincident with a stop bar or clearance bar, where provided. A taxiway intersection marking consists of a single broken yellow line.

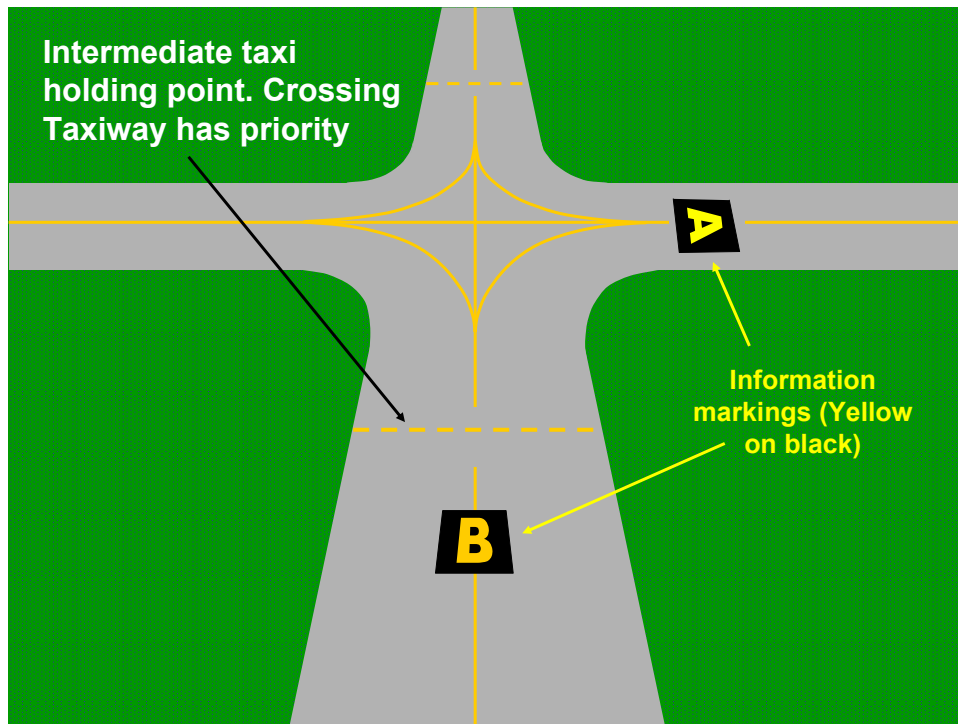

Figure 20.10: Intermediate holding position marking.

20.31 Aircraft Stand Markings. Aircraft stand markings should be provided for designated parking positions on a paved apron and on de/anti icing facilities. They should include such elements as stand identification, lead in line, turn bar, turning line, alignment bar, stop line and lead-out line, as are required by the parking configuration and to complement other parking aids. The stand identification letter and/or number should be included a short distance after the beginning of the lead-in line. The height of the identification should be adequate to be readable from the cockpit of aircraft using the stand. Lead-in, turning and lead out lines should normally be continuous in length. Where one or more sets of stand markings are superimposed on a stand, the lines should be continuous for the most demanding aircraft and broken for other aircraft. The curved portions of lead-in, turning and lead-out lines should have radii appropriate to the most demanding aircraft type for which the markings are intended. Where it is intended that aircraft proceed in one direction only, arrows pointing in the direction to be followed should be added as part of the lead-in and lead-out lines. A turn bar should be located at right angles to the lead-in line, abeam the left pilot position at the point of initiation of any intended turn. The distances to be maintained between the turn bar and the lead-in line may vary according to different aircraft types, taking into account the pilot's field of view. An alignment bar should be placed so as to be coincident with the extended centre line of the aircraft in the specified marking position and visible to the pilot during the final part of the parking manoeuvre. A stop line should be located at right angles to the alignment bar, abeam the left pilot position at the intended point of stop.



Figure 20.11: Aircraft stand markings.

20.32 Road-holding position marking. Road holding position markings are to be provided at all road entrances to a runway. The markings are to be located across the road at the holding position, and will be marked in accordance with the local road traffic regulations.

20.33 Mandatory Information Marking. Where it is impracticable to install a mandatory sign (see Chapter 21), a mandatory instruction marking is to be marked on the surface of the taxiway pavement. Mandatory markings are holding point signs (runway designator in white on a red background) and no entry signs. Pilots are not to pass any mandatory marking unless specifically cleared by ATC.

20.34 Information Marking. Where an information sign would normally be installed but it is physically impracticable, the information is to be displayed on the surface of the pavement. Where operationally required information sign should be supplemented by information marking. The information markings should be displayed across the surface of the taxiway or apron where necessary and positioned so as to be legible from the cockpit of an approaching aircraft. Information marking shall consist of an inscription in yellow, when it replaces or supplements a location sign; and an inscription in black, when it replaces or supplements a direction or destination sign. Where there is insufficient contrast between the marking and the pavement surface, the marking shall include a black background where the inscriptions are in yellow; and a yellow background where the inscriptions are in black. Markings will be combinations of characters and symbols. Markings containing numbers only are only used for runways and runway designators.

SIGNS

20.35 General Specification. Signs are provided on aerodromes to convey a mandatory instruction, information on a specific location or destination on a movement area, or to provide other information as required.

20.36 Characteristics. Signs shall be frangible. Those located near a runway or taxiway shall be sufficiently low to preserve clearance for propellers and the engine pods of jet aircraft. Signs shall be rectangular, with the longer side horizontal. The only signs on the movement area utilizing red shall be mandatory instruction signs. Signs showing number only refer to runways. Signs shall be reflective and/or illuminated when intended for use at night. Signs shall be illuminated when intended for use:

- In runway visual range conditions less than a value of 800m, or
- At night in association with instrument runways, or
- At night in association with non-instrument runways where the code number is 3 or 4.

20.37 Mandatory Instruction Signs. A mandatory instruction sign is provided to identify the location beyond which an aircraft taxiing or vehicle shall not proceed unless authorised by the aerodrome control tower. Mandatory instruction signs include runway designation signs, category I, II and III holding position signs, taxi-holding position signs, road-holding position signs and NO ENTRY signs. A pattern "A" taxi-holding position marking shall be supplemented at a taxiway/runway intersection or a runway/taxiway intersection with a runway designation sign. A pattern "B" taxi-holding position marking shall be supplemented with a category I, II or III holding position sign. A runway designation sign at a taxiway/runway intersection should be supplemented with a location sign in the outboard (farthest from the taxiway) position as appropriate. A NO ENTRY sign shall be provided when entry into an area is prohibited.

20.38 Locations of Signs. Signs are to be located in positions such that pilots (or vehicle drivers) are able to see the sign. Signs are not to be positioned so as to create hazards to aircraft. Signs are positioned as follows:

- A runway designation sign at a taxiway/runway intersection shall be located at least on the left side of a taxiway facing the direction of approach to the runway. Where practicable a runway designation sign shall be located on each side of the taxiway.
- A NO ENTRY sign shall be located at the beginning of the area to which the entrance is prohibited at least on the left hand side of the taxiway as viewed by the pilot. Where practicable, a NO ENTRY sign shall be located on each side of the taxiway.
- A Category I, II or III holding position sign shall be located on each side of the holding position marking facing the direction of the approach to the critical area.
- A taxi-holding position is to be located on the left-side of the taxi-holding position facing the approach to the runway or ILS/MLS critical/sensitive area, as appropriate, and where practicable, on each side of the taxi-holding position.

20.39 Characteristics. A mandatory instruction sign consists of white letters/numbers on a red background. The inscription on a runway designation sign consists of the runway designator. The inscription on a category I, II or III or joint II/III instrument approach holding position sign consists of the runway designator followed by CAT I, CAT II, CAT III, or CAT II/III, as appropriate. The inscription on a taxi-holding position sign shall consist of the taxiway designation and number.

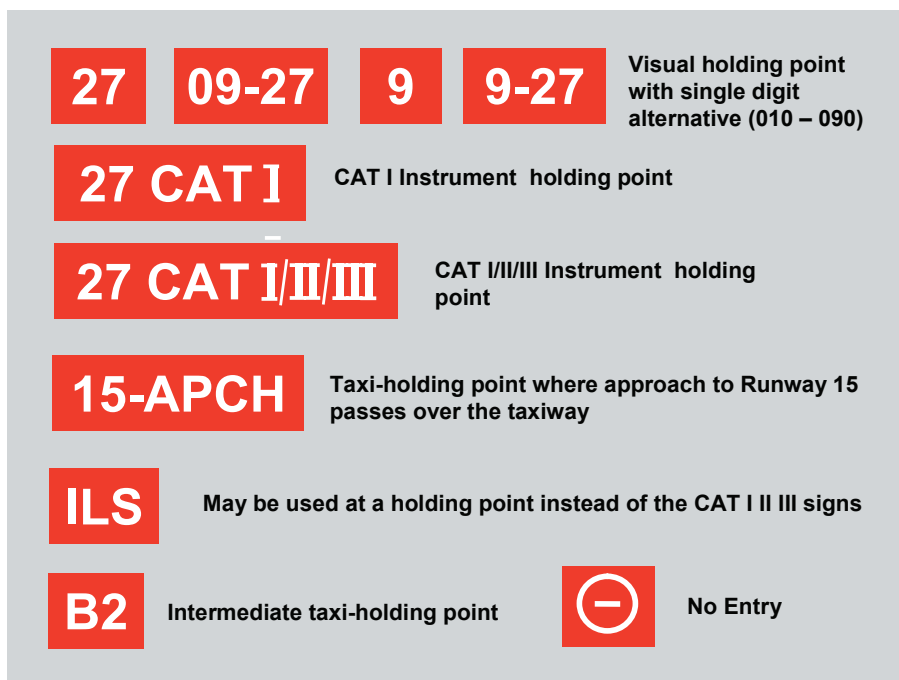

Figure 20.12: Sign characteristics.

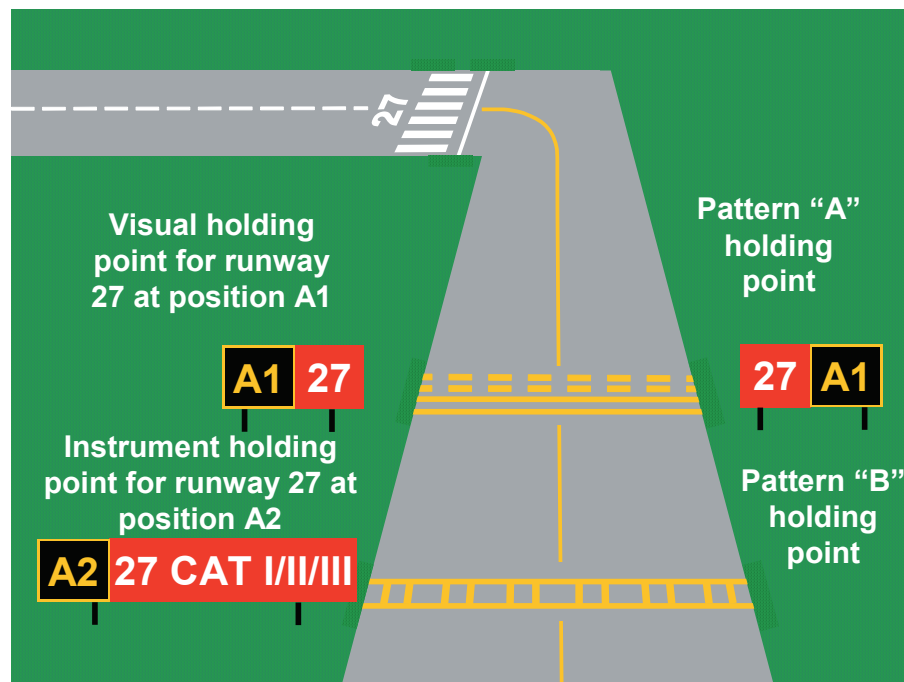

Figure 20.13: Information signs.

20.40 Information Signs. Information signs are provided where there is an operational need to identify by a specific location, or routing (direction or destination). Information signs include: direction signs, location signs, destination signs, runway exit signs and runway vacated signs. Wherever practicable, they are located on the left-hand side of the taxiway. At a taxiway intersection, information signs are located before the intersection and in line with the taxiway intersection marking. Runway exit signs are located on the same side of the runway as the exit is located (i.e. left or right). A runway vacated sign is located at least on one side of the taxiway to indicate when the aircraft is clear of the sensitive area. Where a runway vacated sign and a taxiway location sign are sited, the taxiway location sign is outboard of the runway vacated sign. A taxiway location sign installed in conjunction with a runway designation sign shall be positioned outboard of the runway designation sign. An information sign other than a location sign shall not be collocated with a mandatory instruction sign.

20.41 Characteristics. The colour and symbology of information signs is as follows:

- **Information Signs** (except location signs), consist of an inscription in black on a yellow background.
- **Location Signs** consist of an inscription in yellow on a black background and where it is a stand alone sign, has a yellow border.
- The inscription on a runway exit sign consists of the designator of the exit taxiway and an arrow indicating the direction to follow.
- The inscription on a runway vacated sign depicts the pattern 'A' taxi-holding position marking.

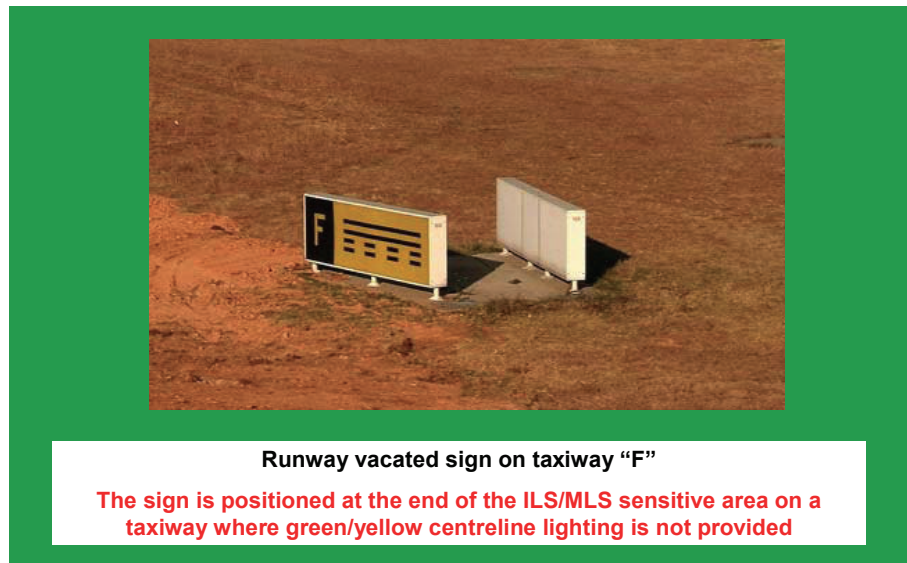

Figure 20.14: Runway vacated taxiway F.

- The inscription on a destination sign identifies the destination with an arrow indicating the direction to proceed.



Figure 20.15: Runway 02 straight ahead: holding point D3 to the right.

- The inscription on a direction sign identifies the taxiway(s) with an arrow (or arrows) appropriately oriented.
- The inscription on a location sign is the designation of the location taxiway, runway or other pavement the aircraft is on or is entering.

Note: Where it is necessary to identify each of a series of taxi-holding positions on the same taxiway, the location sign should consist of the taxiway designation and number.

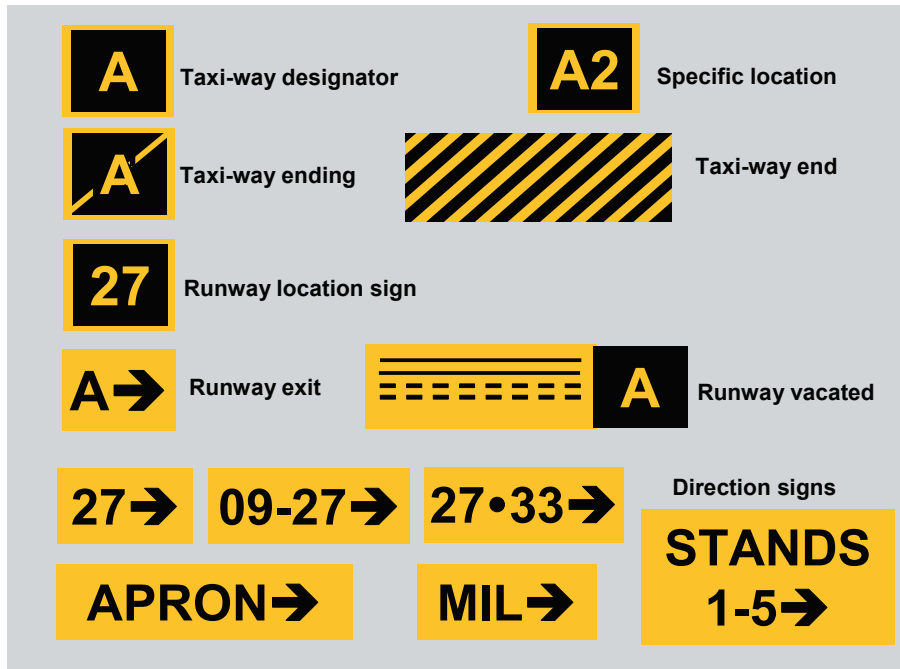

Figure 20.16:

20.42 Combination Signs. Where a location sign and direction signs are used in combination, signs related to left turns are placed on the left side of the location sign and all direction signs related to right turns are placed on the right side of the location sign.

Exception: Where the junction consists of one intersecting taxiway, the location sign may be placed on the left hand side. Adjacent signs are delineated by a vertical black line.

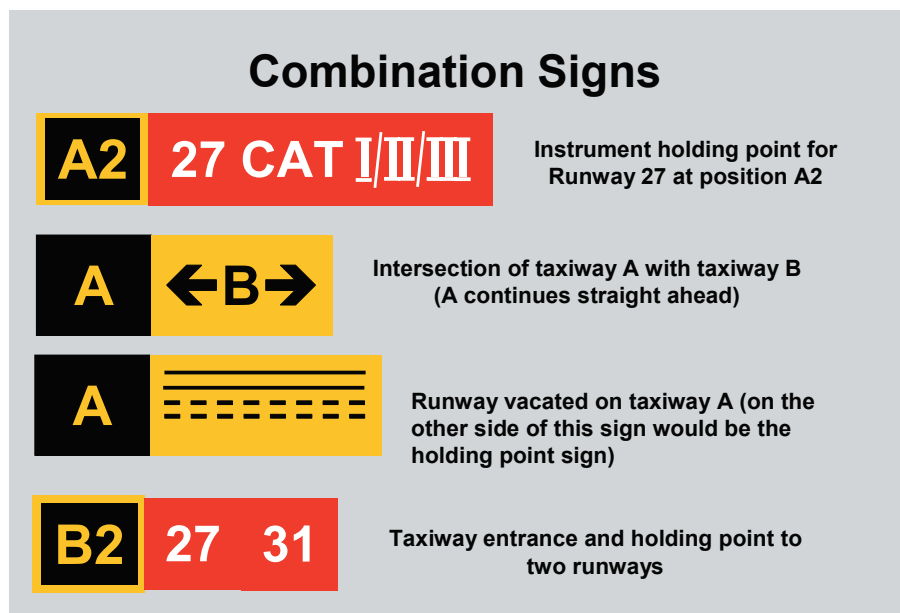

Figure 20.17: Combination signs.

20.43 Taxiway Designators. Taxiways are identified by a designator comprising a letter(s) or a combination of a letter(s) followed by a number. When designating taxiways, the use of the letters I, O or X and the use of words such as inner and outer should be avoided wherever possible to avoid confusion with the numerals 1, 0 and closed marking. The use of numbers alone on the manoeuvring area is reserved for the designation of runways.

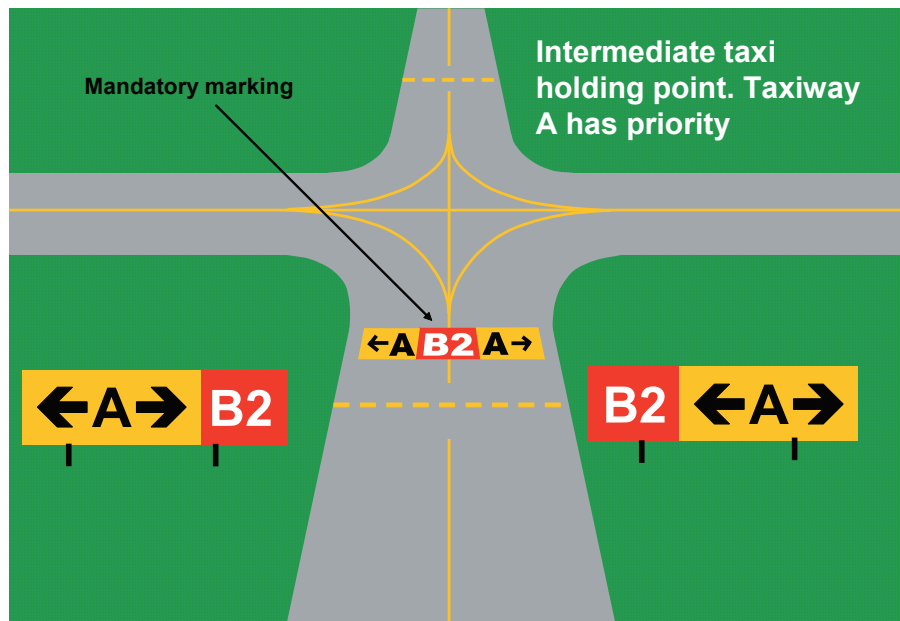

Figure 20.18:

20.44 Aircraft Stand Identification Signs. An aircraft stand identification marking (see paragraph 20.53) should be supplemented with a sign where feasible. The sign should be located so as to be clearly visible from the cockpit of an aircraft prior to entering the stand. The sign consists of an inscription in black on a yellow background. Alternatively in Europe this may be white on a blue background.

20.45 Road-Holding Position Sign. Road-holding position signs are provided at all road entrances to runways. The road-holding position sign is to be located 1.5m from the edge of the road (left or right as appropriate to the local traffic regulations) at the holding position. A road-holding position marking sign consists of an inscription in white on a red background. If the sign is intended for night use, it is to be reflective or illuminated. The inscription on a road-holding position sign is to be in the national language, must conform to the local traffic regulations and include a requirement to stop; a requirement to obtain an ATC clearance; and the location designator.

MARKERS

20.46 Definition. A marker is an object which is displayed above ground level in order to indicate an obstacle or delineate a boundary. Markers are used where lights are not provided or where lighting (or ground markings) does not serve the purpose. Typically, edge markers may be used to indicate the extremity of a taxiway where snow has fallen, or to mark areas of bad ground on a grass aerodrome. Their height shall be sufficiently low to preserve clearance for propellers and for the engine pods of jet aircraft. At Oxford, the refuelling area is marked by reflective green markers.

20.47 Unpaved Runway Edge Markers. Markers should be provided when the extent of an unpaved runway is not clearly indicated by the appearance of its surface compared with that of the surrounding ground. Where runway lights are provided, the markers should be incorporated in the light fixtures. Where there are no lights, markers of flat rectangular or conical shape should be placed so as to delimit the runway clearly. The flat rectangular markers should have a minimum size of 1m by 3m and should be placed with their long dimension parallel to the runway centre line. The conical markers should have a height not exceeding 50cm.

20.48 Taxiway Edge Markers. Taxiway edge markers should be provided on a taxiway where centre line or edge lights or taxiway centre line markers are not provided. The markers should be installed at least at the same locations as would the taxiway edge lights had they been used. Markers are required to be reflective blue. Taxiway edge markers shall be frangible.

20.49 Taxiway Centre Line Markers. Taxiway centre line markers should be provided on a taxiway where edge lights or taxiway edge markers are not provided. The markers should be installed at least at the same location as would taxiway centre line lights had they been used. The markers should normally be located on the taxiway centre line marking, except that they may be offset by not more than 30cm where it is not practicable to locate them on the marking. Taxiway centre line markers are reflective green. The markers shall be so designed and fitted to withstand being run over by the wheels of an aircraft without damage either to the aircraft or to the markers themselves.

20.50 Unpaved Taxiway Edge Markers. Where the extent of an unpaved taxiway is not clearly indicated by its appearance compared with that of the surrounding ground, markers should be provided. Where taxiway lights are provided, the markers should be incorporated in the light fixtures. Where there are no lights, markers of conical shape should be placed so as to delimit the taxiway clearly.

20.51 Boundary Markers. Boundary markers shall be provided at an aerodrome where the landing area has no runway. Boundary markers shall be spaced along the boundary of the landing area at intervals of not more than 200m, if the type shown below is used, or approximately 90m, if the conical type is used with a marker at any corner. Boundary markers should be of a form similar to those shown below, or in the form of a cone not less than 50cm high and not less than 75cm in diameter at the base. The markers should be coloured to contrast with the background against which they will be seen. A single colour, orange or red, or two contrasting colours, orange and white or alternatively red and white, should be used, except where such colours merge with the background.

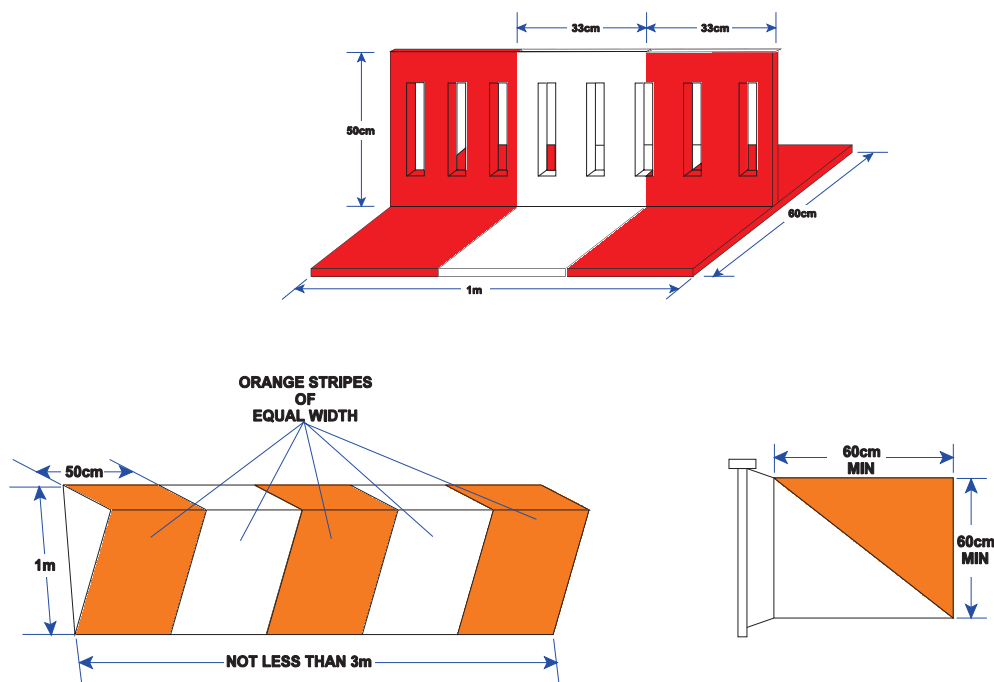

Figure 20.19: Boundary markers.

20.52 Fixed Distance Markers. Fixed distance markers are used to indicate the length of runway remaining. They consist of white numbers on a black background and are positioned on the side of the runway at intervals of 1000ft counting down as the end of the runway approaches. The first marker is positioned 1000ft (300m) from the threshold of the landing runway. These are commonly called 'distance to go' markers and are mainly used at military aerodromes.

20.53 Parking Stand Markers. These are positioned as markings at the entrance to a parking stand or as a sign positioned on a building at the end of the stand. The marker consists of white inscriptions on a blue background.



Fixed Distance Markers ('Distance-to-go')

Boards displaying white numerals at intervals along the left side of a runway indicate the distance (in 1000s of feet) to the end of the runway. Used on runways greater than 4000 ft long. The first marker is positioned 1000ft (300m) from threshold.



Parking Stand Markers/Signs

Signs and markings with yellow characters on a black background are used on aprons to provide pilot information – stand identification etc



Alternatively, white characters on a blue background are used in Europe

Figure 20.20: Fixed distance and parking stand markers.

VISUAL DOCKING GUIDANCE SYSTEMS

20.54 Introduction. Visual Docking Guidance systems (sometimes referred to as Nose-in Docking Guidance systems or Stand Entry Guidance systems) provide guidance where pilot interpreted alignment and stopping information is required for accurate parking, particularly at air-bridges. ICAO states that aircraft stand manoeuvring guidance lights should be provided to facilitate the positioning of an aircraft on an aircraft stand on a paved apron, or on a de/anti icing facility intended for use in poor visibility conditions, unless adequate guidance is provided by other means. There are no learning objectives concerning Visual Docking Systems, but students are advised to read Chapter 4 of CAP637, just in case a question comes up in the examination.

QUESTIONS

1. How are the runways designated at an aerodrome where there are three parallel runways?
 - a. 02; 03; and 04.
 - b. The QDM for the third runway will be increased by 10°.
 - c. The L and R runways will have different QDM.
 - d. The QDM with 'L'; 'C' and 'R' added.

2. Runway threshold marking consists of a number of stripes. How many stripes are there for a runway width of 60 metres?
 - a. 6
 - b. 8
 - c. 12
 - d. 16

3. Touchdown zone markings are set out in pairs. How many such pairs are required for a runway of 2400 m or more?
 - a. 6
 - b. 4
 - c. 2
 - d. 8

4. A transverse white stripe on a runway is associated with:
 - a. a closed runway.
 - b. a runway which is 2400 metres or longer.
 - c. a displaced threshold.
 - d. a runway available for circling to land approaches.

5. Which of the following statements is correct?
 - a. Taxiway markings are white and runway markings are yellow.
 - b. Numerals on aerodrome signs are reserved for runways.
 - c. A clearway has the same function as a RESA.
 - d. The pairs of touchdown zone markings are separated from each other by 120 metres.

6. If a runway is 2000m in length, how close to the runway centre line is the nearest taxiway holding point?
 - a. 50m.
 - b. 35m.
 - c. 40m.
 - d. 75m.

7. Which of the following statements are correct?
 - a. Runway markings are white and taxiway markings are yellow.
 - b. Runway and taxiway markings are white.
 - c. Runway and taxiway markings are yellow.
 - d. Runway markings are yellow and taxiway markings are white.

8. On an instrument approach runway which is more than 2400m long there will be:
- a. an aiming point marking and centre line markings only.
 - b. touchdown zone markings and centre line markings only.
 - c. aiming point markings and touchdown zone markings.
 - d. an aiming point marking 150m from the threshold.
9. Which of the following concerning Aerodrome signs is correct?
- a. Mandatory signs: Black background with red inscription.
 - b. Information signs: Black or yellow background with black or yellow inscription.
 - c. Mandatory signs: Red background with black inscription.
 - d. Information signs: Orange background with black inscription.
10. Where fixed distance marking is provided, this shall commence:
- a. at 100m from the threshold.
 - b. at 150m from the threshold.
 - c. at 300m from the threshold.
 - d. at 500m from the threshold.

ANSWERS

Question	Answer	Reference
1.	D	20.10
2.	D	20.15
3.	A	20.20
4.	C	20.16
5.	B	20.36
6.	D	20.28
7.	A	20.8 / 20.23
8.	C	20.8
9.	B	20.41
10.	C	20.52

**CHAPTER TWENTY ONE
AERODROME LIGHTING**

Contents

AERODROME LIGHTS	391
APPROACH LIGHTING SYSTEMS	392
RUNWAY LIGHTING	400
TAXIWAY LIGHTING	401
QUESTIONS	405
ANSWERS	408

AERODROME LIGHTS

21.1 Introduction. The profusion of lights on an aerodrome can be both confusing and disorientating, but each light or lighting system has a purpose and most are to do with aircraft safety. In this chapter the various lighting systems are described and their uses explained. The learning objectives state that knowledge of lighting systems is required, but the spacing of lights or groups of lights (excluding approach lighting systems) is outside the scope of the course. The design of lighting systems is also beyond this course. It is an unfortunate fact of life that there is no standard system of lighting in use although ICAO has laid down the standards and recommended practices in Annex 14.

21.2 Aircraft Safety. A non-aeronautical light near an aerodrome which might endanger the safety of an aircraft is to be extinguished, screened or otherwise modified so as to eliminate the source of danger.

21.3 Elevated Lights. Elevated runway, stopway and taxiway lights shall be frangible. Their height shall be sufficiently low to preserve clearance for propellers and for the engine pods of jet aircraft. Where not sufficiently conspicuous, they are to be suitably marked.

21.4 Light Intensity. In poor visibility conditions by day, lights can be more effective than marking. For lights to be effective in such conditions or in poor visibility by night, they must be of adequate intensity. To obtain the required intensity, it will usually be necessary to make the light directional, in which case the arcs over which the light show will have to be adequate and so orientated as to meet the operational requirements. The runway lighting system will have to be considered as a whole, to ensure that the relative light intensities are suitably matched to the same end. The intensity of runway lighting shall be adequate for the minimum conditions of visibility in ambient light in which use of the runway is intended, and compatible with that of the nearest section of the approach lighting system when provided. While the lights of an approach lighting system may be of higher intensity than the runway lighting, it is good practice to avoid abrupt changes in intensity as these could give a pilot a false impression that the visibility is changing during approach.

21.5 Intensity Control. Where a high intensity lighting system is provided, a suitable intensity control shall be incorporated to allow for adjustment of the light intensity to meet the prevailing conditions. Separate intensity controls or other suitable methods shall be provided to ensure that the following systems, when installed, can be operated at compatible intensities:

- approach lighting system
- runway edge lights
- runway threshold lights
- runway end lights
- runway centre line lights;
- runway touchdown zone lights
- taxiway centre line lights

21.6 Availability. Lights may be turned off providing that they can be turned on again within a period of 1 hour.

21.7 Emergency Lights. Normally, an aerodrome will have an alternate power supply to cope with general power failures. Where no such back-up supply exists, emergency lights are to be available for at least the primary runway.

21.8 Aeronautical Beacons. Where operationally necessary an aerodrome beacon or an identification beacon is to be provided where the aerodrome is intended for use at night. The need for a beacon is to be determined having regard to the requirements of the air traffic using the aerodrome, the conspicuity of the aerodrome features in relation to its surroundings and the installation of other visual and non-visual aids useful in locating the aerodrome.

21.9 Aerodrome Beacon. An aerodrome beacon shows 'flashes' of light. For land aerodromes the colours are white or white and green and for water aerodromes, white or white and yellow. Beacons are to be provided at an aerodrome intended for use at night if one or more of the following conditions exist:

- Aircraft navigate predominantly by visual means;
- Reduced visibilities are frequent; or
- It is difficult to locate the aerodrome from the air due to surrounding lights or terrain.

21.10 Identification Beacon. An identification beacon is provided at an aerodrome which is intended for use at night and cannot be easily identified from the air by any other means. An identification beacon will show Morse code identification of the aerodrome in flashing green at a land aerodrome (red at a UK military aerodrome) and flashing yellow at a water aerodrome.

APPROACH LIGHTING SYSTEMS

21.11 General. Approach lighting systems are patterns of fixed lights of variable intensity, showing white, designed to give the pilot guidance to the threshold (or aiming point) of a runway, in poor visibility or at night. The light patterns may include distance coding and give an indication of aircraft attitude. The arrangement may also give an indication of aircraft height above the approach plane. Systems can range in complexity from a simple centre line and cross bar, to the highly intricate layouts associated with Cat III precision instrument approach systems. The determination of the visual criteria for landing can be met by the visual acquisition of the approach light system and the design must cater for the requirement of the most restrictive decision heights and minimum descent heights. The primary unit of design is the length of the segments, set by ICAO at 300m. ICAO requires that all the existing lighting systems not conforming to the ICAO specification standards are to be replaced by 1 Jan 2005. Any ILS or MLS azimuth antenna protruding through the plane of the lights shall be treated as an obstacle and marked and lit accordingly.

21.12 Calvert Systems. Generally used in the UK and occasionally in other parts of the world, Calvert systems (named after the inventor) consist of 5 bars and a distance coded centreline. A NATO system is similar but doesn't have the distance coding of the centreline.

21.13 Barrettes. The individual lights that make up the lighting systems may be arranged either as single light units (as in the Calvert method) or in the form of groups of three or more lights arranged as a bar (the ICAO method). For instance the centre line of a system may consist of either single point source lights or a bar of 5 lights close together. The arrangement of 5 close together is called a 'barrette' (pronounced barre - et meaning small bar). They are called barrettes so that they are not confused with the bar constituent parts of any approach lighting system.

21.14 Simple Approach Lighting System. A simple approach lighting system consists of a row of lights on the extended centre line of the runway extending, whenever possible, over a distance of not less than 420m from the threshold with a row of lights forming a crossbar 18m or 30m in length at a distance of 300m from the threshold. The lights forming the crossbar shall be as nearly as practicable in a horizontal straight line at right angles to, and bisected by, the line of the centre line lights. This type of system is used on a non instrument runway and may be used on a non precision instrument runway.

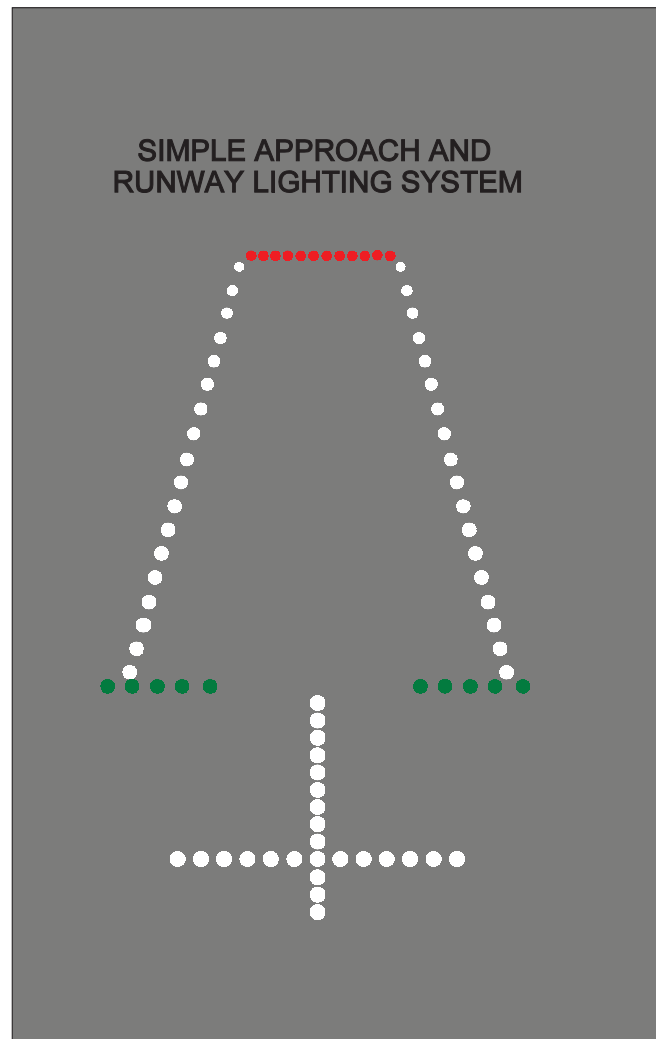

Figure 21.1: Simple approach lighting system.

21.15 Precision Approach CAT I Lighting System. A precision approach category I lighting system consists of a row of lights on the extended centre line of the runway extending, wherever possible, over a distance of 900m from the runway threshold. If the length is less than 900m (which on a 3° glide path coincides with CAT 1 system minima - 200 ft) it is possible that an aircraft may not be over the approach lighting at DH. The 5 crossbars are 150m apart and form three segments: the inner segment (0 - 300m); the middle segment (300 - 600m); and the outer segment (600 - 900m). Any ILS or MLS azimuth antenna protruding through the plane of the lights will be treated as an obstacle and marked and lit accordingly.

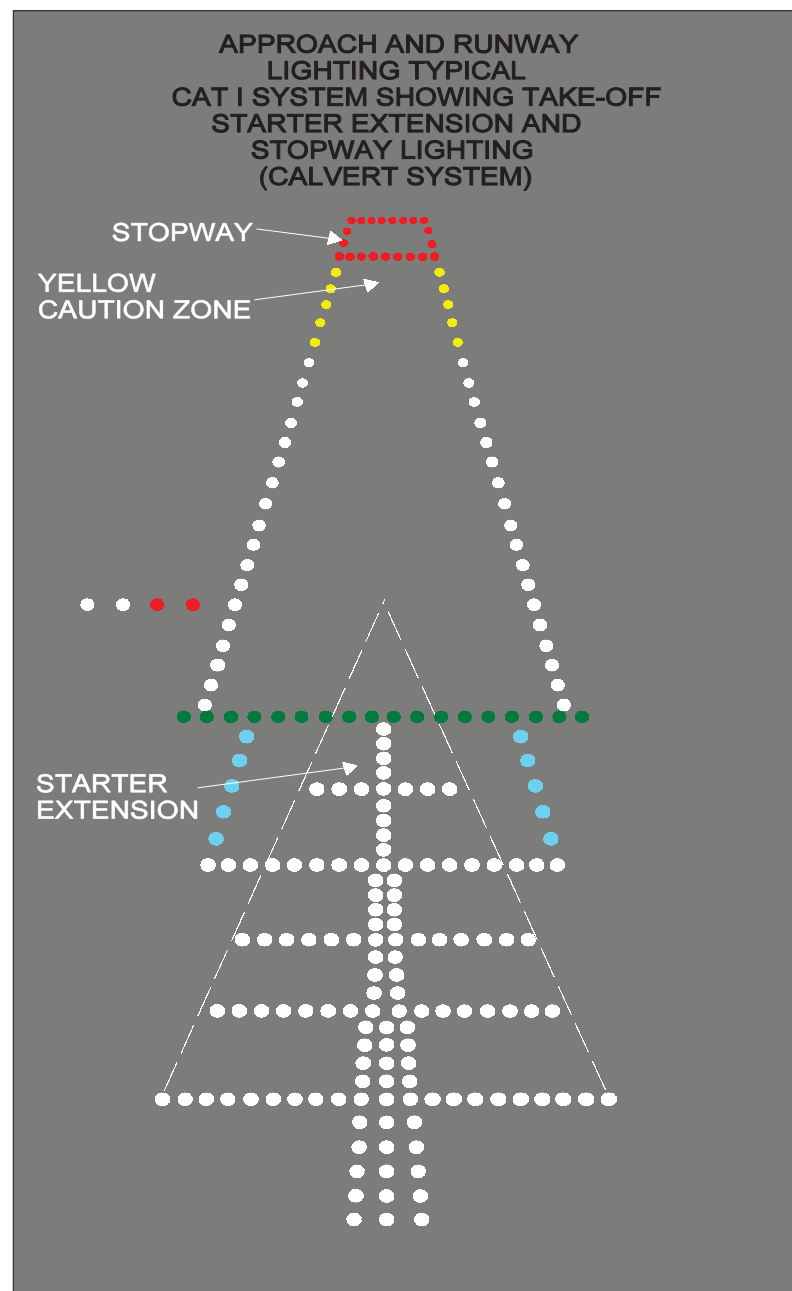

Figure 21.2: Cat I Calvert 5 bar and centre line system.

21.16 ICAO Precision Approach CAT I Lighting System. In this arrangement, the centreline is in the form of barrettes with only one crossbar at 300m from the threshold. Again, the centreline should be 900m in length. The centreline may be augmented with strobe lights that 'ripple' towards the threshold from the start of the centreline. The visibility of the threshold may be enhanced by the use of wing strobes (rotating).

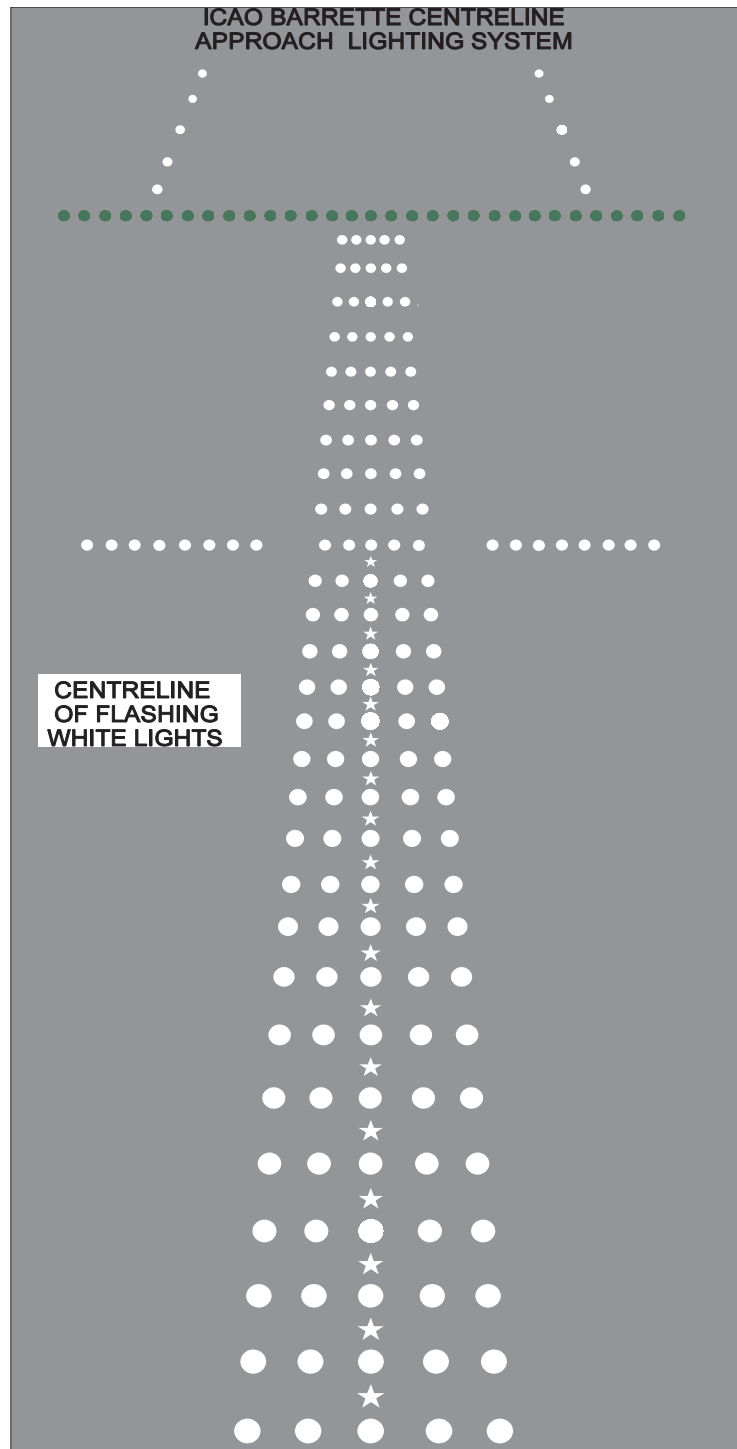

Figure 21.3: ICAO Cat I approach lighting system.

21.17 **Precision Approach Category II/III Lighting System.** At those aerodromes where Cat II and III approaches are conducted more complex approach lighting system are installed to enhance the possibility of the pilot achieving the visual criteria at DH to complete the landing. The systems used are various but all are based on either the Calvert 5 bar and centreline system, or the ICAO barrette system. Both systems should be 900m long and provide some element of attitude information. In both the Calvert and the ICAO systems the inner segment (0 - 300m from the threshold) is augmented by the supplementary approach lighting. This consists of replacing the centreline of the Calvert system with barrettes and adding red wing barrettes to both systems. The effect is to enhance the visibility and conspicuity of the inner segment. DH for Cat 2 is not lower than 100 ft which equates to 300m from the threshold (assuming the pilot crosses the threshold at 50 ft).

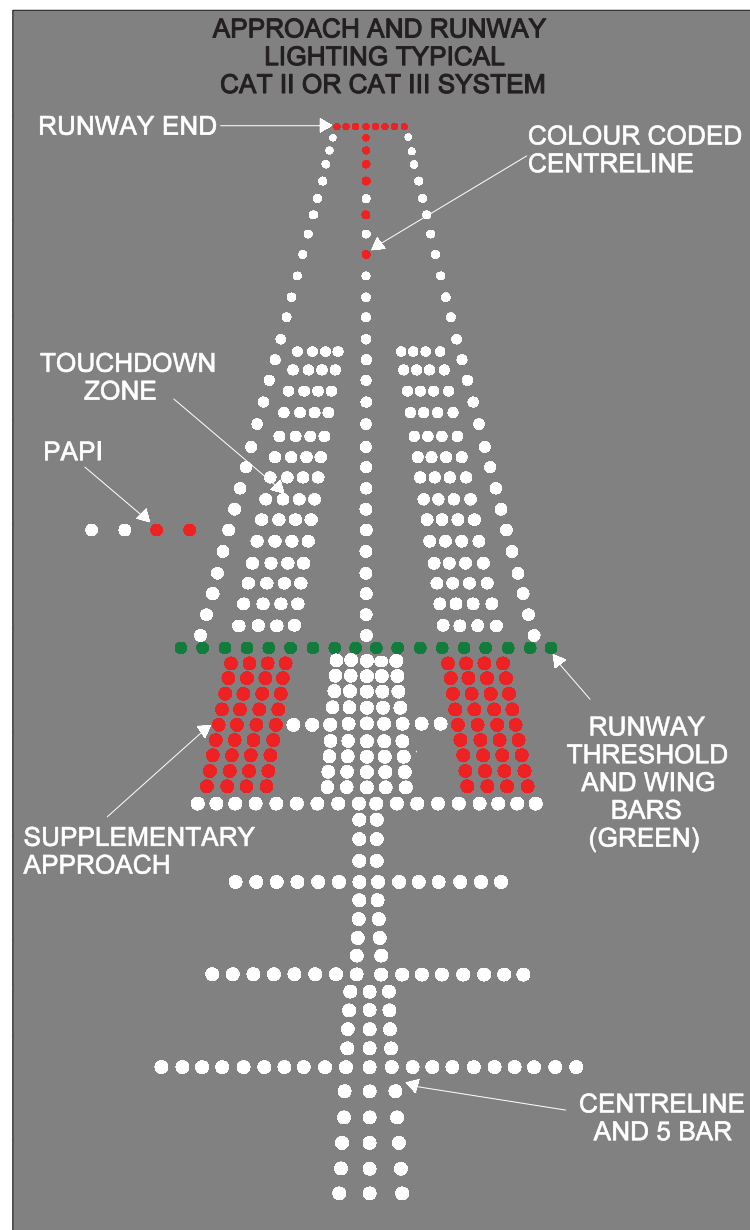

Figure 21.4: Approach & runway Cat II/III lighting system.

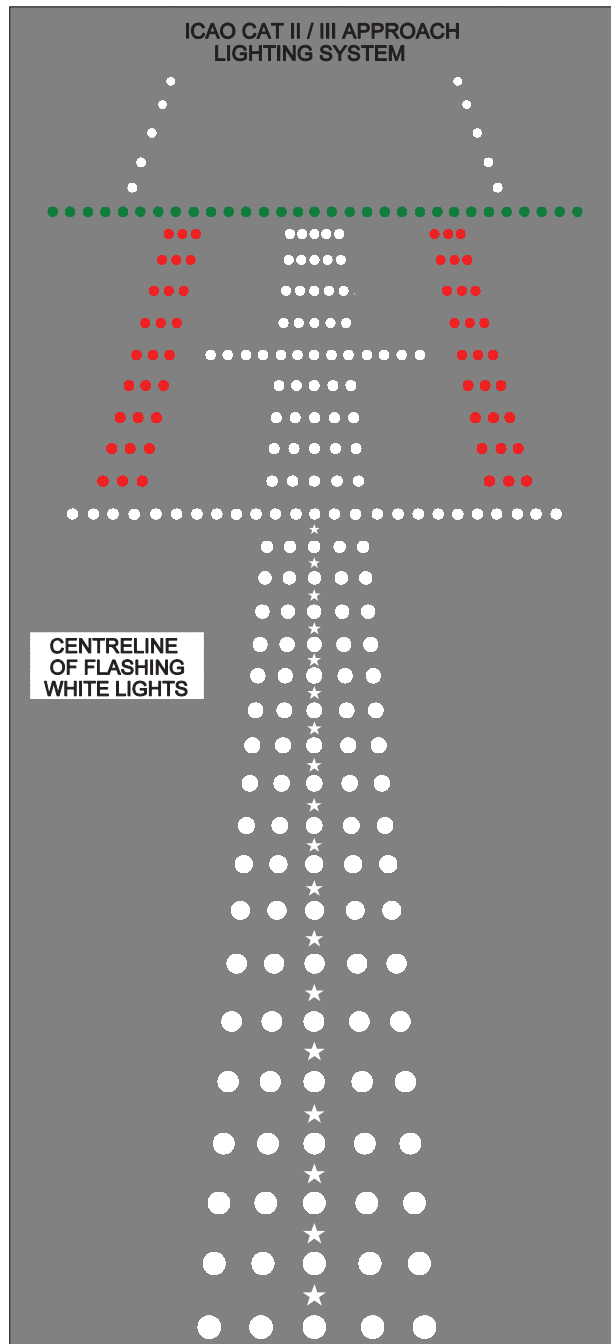

Figure 21.5: ICAO Cat II/III approach lighting system.

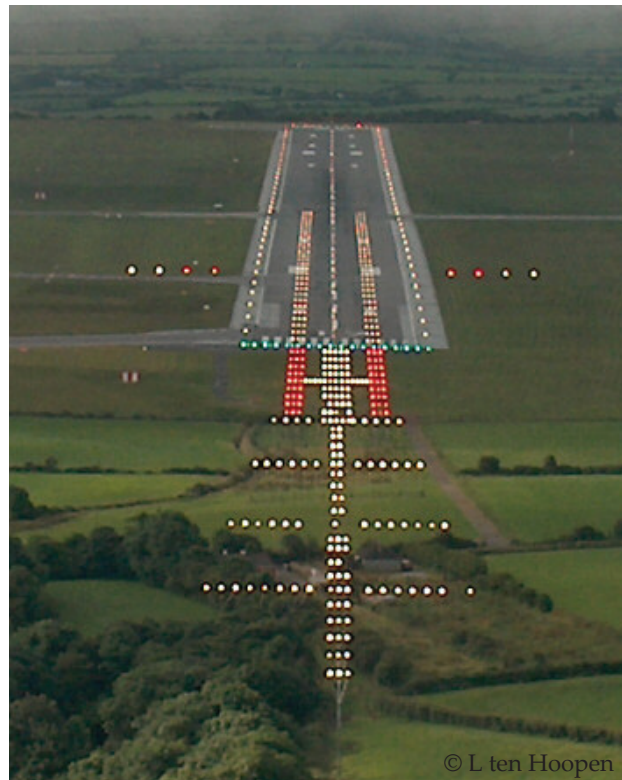

Figure 21.6: Calvert Cat III/III system at Cork.

21.18 Precision Approach Path Indicators (PAPI). As an additional aid to a precision approach, glide path guidance is provided during the visual phase (after DH) by the PAPI lighting system. This consists of 4 light units showing either red or white light through precision defined angles. Each light unit is set to a different mid angle and below that angle shows red and above shows white. The effect is to white light to aircraft above the mid angle and red below. The overall effect is to give a reference to the median angle which is set to the required glide path (i.e. 3°).



Installation by: Godfrey Systems International, Inc

Figure 21.7: Precision approach path indicators (PAPI).

21.19 PAPI Indications. The possible combinations of the 4 light sets give 5 different indications relating to the aircraft position (correctly, the pilot's eye) with respect to the defined glide path.

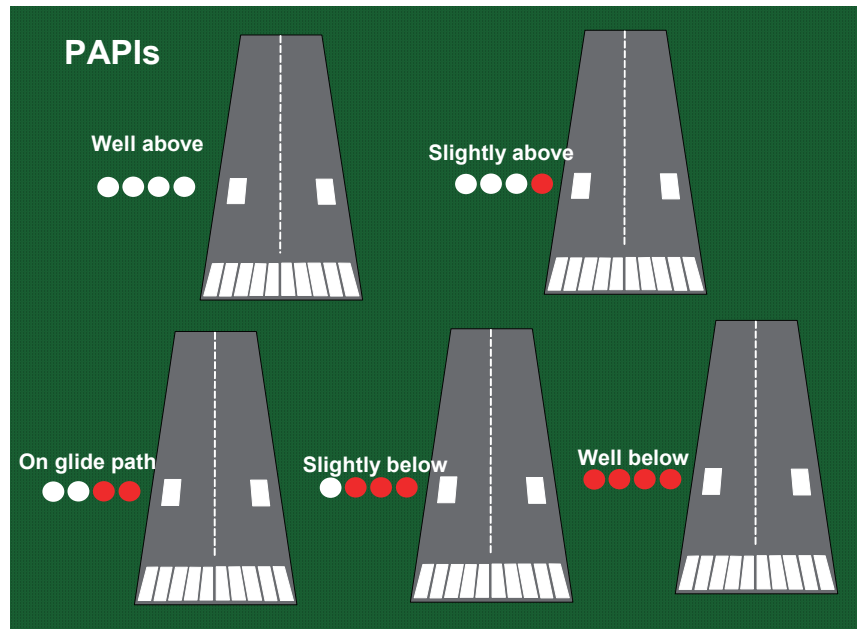

Figure 21.8: PAPI indications.

21.20 Circling Approach. Where the runway is used for circling approaches (visual manoeuvring circling) a PAPI set is placed on either side of the runway. Normally there would only be one set on the left hand side. This allows the pilot to use the PAPI wing bars as a horizontal reference for aircraft attitude during the later part of the circling manoeuvre.

21.21 Minimum Eye Height (MEHT). If the PAPI system was located exactly at the threshold of the runway, and the pilot flew a visual approach keeping the aircraft exactly at the 'on glide path' position, the wheels of the aircraft would hit the ground before the aircraft reached the threshold. The distance before the threshold where the wheels hit the ground would be a function of the distance from the pilot's eye to the bottom of the undercarriage. To overcome this, the visual aiming point (coincident with the PAPI location) is set a distance down the runway. On code 4 instrument runways at least 2,400m in length, the aiming point is set 400m from the threshold in which case, for a normal 3° glide path, the pilot's eye would be 67 ft above the surface on crossing the threshold. This assumes that the 'on glide path' indication is the 'mid angle', when in fact it is encompassed in a bandwidth of angles within which the 'on glide path' indication is visible. If the height of the pilot's eye can be established when the aircraft is over the threshold with the lowest possible 'on glide path' indication, this could be used to determine if an aircraft can use the PAPI system as set up for that runway. The figure quoted on the ICAO aerodrome chart is the MEHT (minimum eye height) and is printed alongside the location of the PAPI on the chart. During type rating instruction, you will be made aware of the 'eye to undercarriage' requirement of the type, so that you can assess the usability of the PAPIs.

RUNWAY LIGHTING

21.22 Runway Edge Lights. Runway edge lights are provided for a runway intended for use at night or for a precision approach runway intended for use by day or night, and should be provided on a runway intended for take-off with an operating minimum below an RVR of the order of 800m by day. Runway edge lights are placed along the full length of the runway in two parallel rows equidistant from the centre line. The lights shall be uniformly spaced. At intersections of runways, lights may be spaced irregularly or omitted, provided that adequate guidance remains available to the pilot. Runway edge lights are fixed, variable intensity white showing in the direction from which approaches are made. In the case of a displaced threshold, the lights between the beginning of the runway and the displaced threshold show red in the approach direction. A caution zone may be established over the last 600m (or $\frac{1}{3}$ rd of the runway whichever is least) where the lights are yellow. When the runway edge lights are intended to provide circling guidance, they shall show all round (omni-directional).

21.23 Runway Threshold and Wing Bar Lights. Runway threshold lights are provided for a runway equipped with runway edge lights (except on a non-instrument or non-precision approach runway where the threshold is displaced and wing bar lights are provided). When the threshold is at the extremity of a runway, the threshold lights are placed in a row at right angles to the runway axis as near to the extremity of the runway as possible. For a displaced threshold, the lights are in the form of a barrette (wing bar) either side of the displaced threshold. Runway threshold and wing bar lights are to be fixed, unidirectional lights showing green in the direction of approach to the runway.

21.24 Runway End Lights. Runway end lights are provided for a runway equipped with runway edge lights. Runway end lights are fixed, unidirectional lights showing red in the direction of the runway. Runway end lights are placed in a line at right angles to the runway axis as near to the end of the runway as possible, and should consist of at least six lights. The lights should be either equally spaced between the rows of runway edge lights, or symmetrically disposed about the runway centre line.

21.25 Runway Centre Line Lights. Runway centre line lights are provided on Cat II/III precision approach runways. They should be provided on a Cat I precision approach runway where the width between the runway edge lights is greater than 50m. Runway centre line lights are to be provided on a runway intended to be used for take-off with an operating minimum below an RVR of the order of 400m. Runway centre line lights are fixed, variable intensity white. Over the last 900m from the runway end, the lights show alternate red and white from 900m to 300m from the runway end; and all red from 300m to the runway end.

21.26 Runway Touchdown Zone Lights. Touchdown zone lights are provided in the touchdown zone of a Cat II/III precision approach runway. Touchdown zone lights extend from the threshold for a distance of 900m where the runway is 1800m or more in length. The lights are arranged in the form of strips either side of the centre line, the width of the strips is to be the same width as the touchdown zone markings. Touchdown zone lights are fixed, variable intensity, unidirectional showing white.

21.27 Stopway Lights. Stopway lights are provided for a stopway intended for use at night with the lights placed along the full length of the stopway. Stopway lights shall be fixed, variable intensity, unidirectional lights showing red in the direction of the runway.

TAXIWAY LIGHTING

21.28 Application. Taxiway lighting provides pilots with guidance and information during the taxi to and from the runway. It consists of centreline lights, edge lights, guard lights, and stop lights at holding points.

21.29 Taxiway Edge Lighting. Taxiway edge lighting is provided along the edges of holding bays, de/anti-icing facilities, aprons etc. It is intended for use at night on taxiways not provided with taxiway centre line lighting. If, however, sufficient alternative illumination is available (i.e. stadium lighting) then the edge lights may be dispensed with. Where a runway forms part of a standard taxi route intended for use at night and no taxiway centre line lighting exists, edge lights are to be provided. Taxiway edge lights are fixed, variable intensity omni-directional blue.

21.30 Taxiway Centre Line Lights. Taxiway centre line lights are provided on an exit taxiway, taxiway and apron intended for use in runway visual range conditions less than a value of 350m, in such a manner as to provide continuous guidance from the runway centre line to the point on the apron where aircraft commence manoeuvring for parking. These lights need not be provided where there is a low volume of traffic and taxiway edge lights and centre line marking provide adequate guidance. Taxiway centre line lights shall be provided on a runway forming part of a standard taxiway route and intended for taxiing in runway visual range conditions less than a value of 350m. Taxiway centre line lights are fixed, variable intensity showing green such that the light is visible only from the aeroplanes on or in the vicinity of the taxiway. Within the ILS/MLS critical/sensitive area, the centre line lights are alternating green and yellow. Where aircraft may follow the same centre line in both directions, all the centre line lights shall show green to aircraft approaching the runway.

21.31 Stop Bars. Stop bars are a row of red lights showing in the direction of taxiing aircraft and when illuminated require the aircraft to stop and not proceed until cleared by ATC. One or more stop bars, as appropriate, should be provided at a taxiway intersection or taxi-holding position when it is desired to supplement markings with lights and to provide traffic control by visual means. A stop bar shall be provided at every taxi-holding position serving a runway when it is intended that the runway will be used in runway visual range conditions less than a value of 350m. Where the normal stop bar lights might be obscured (from a pilot's view), for example, by snow or rain, or where a pilot may be required to stop the aircraft in a position close to the lights that they are blocked from view by the structure of the aircraft, a pair of elevated lights should be added to each end of the stop bar.

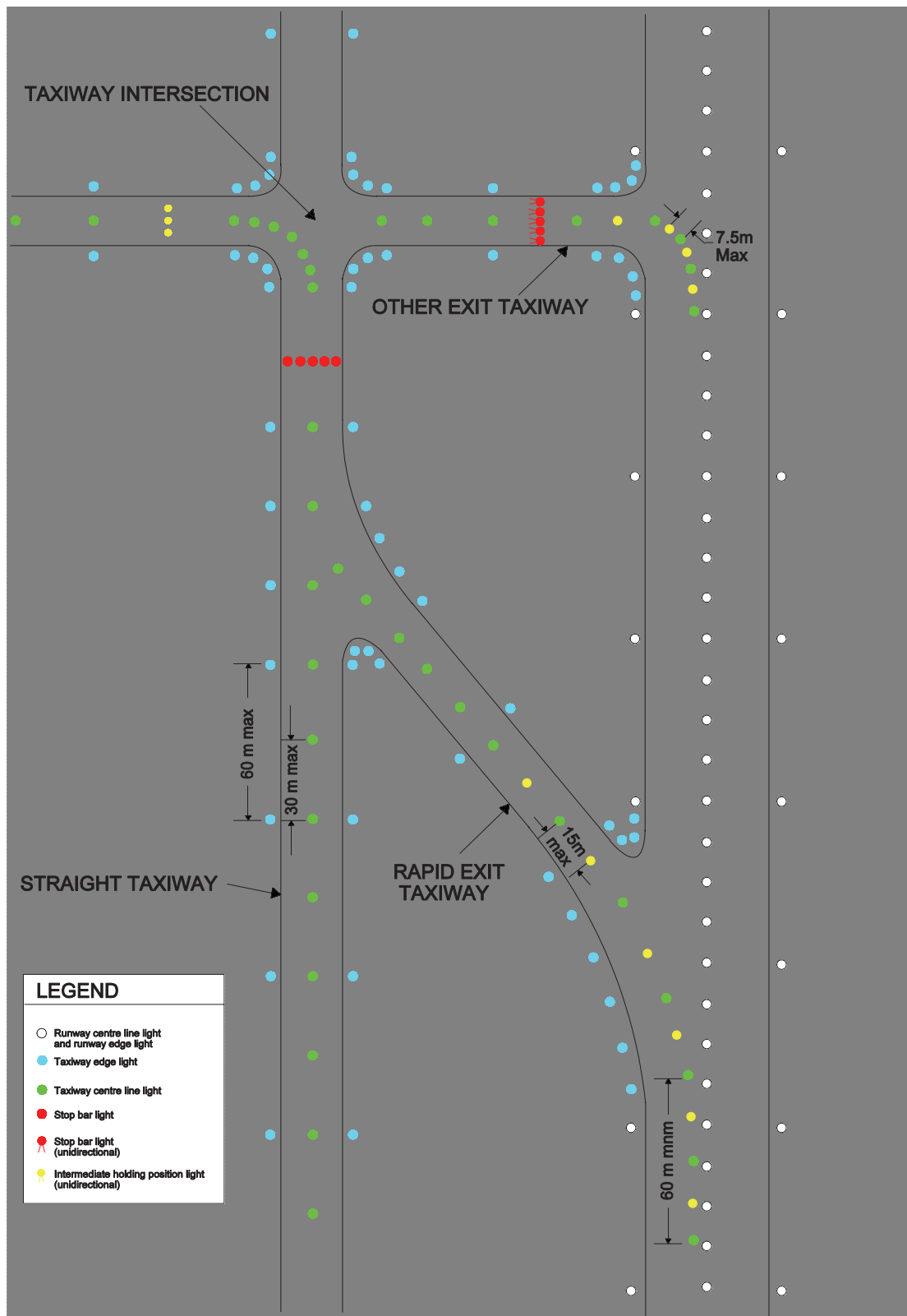

Figure 21.9: Arrangements of runway and taxiway lighting.

21.32 Runway Guard Lights. These are used to warn pilots and drivers of vehicles that they are about to enter an active runway. They are installed at the entrance to runways used in RVR conditions less than 550m where a stop bar is not fitted, and in RVR conditions of 550 - 1200m where traffic density is high. There are two configurations of runway guard lights known as Configuration A and Configuration B. The lights are flashing yellow and show in the direction of taxiing aircraft.

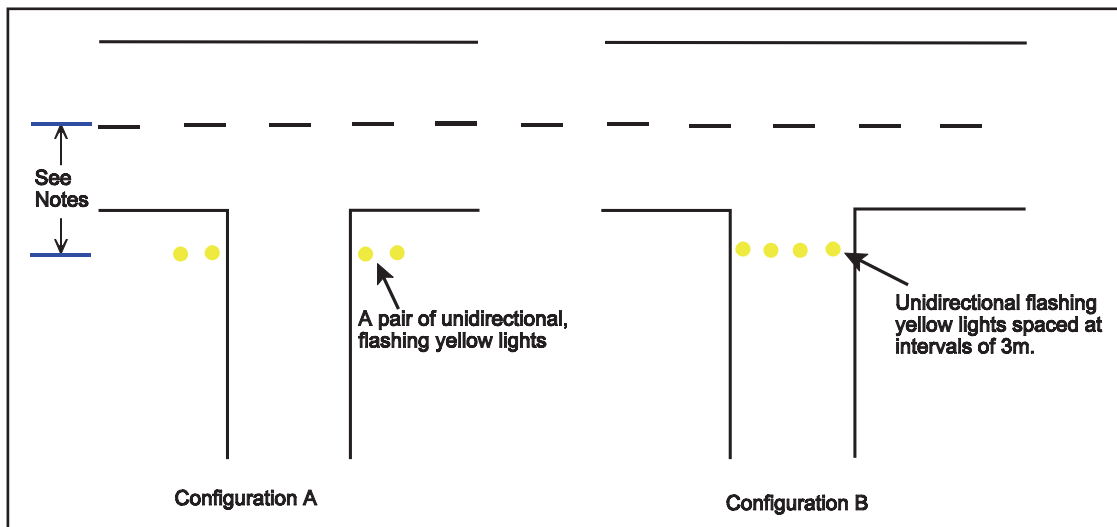

Figure 21.10: Runway and guard lights.

QUESTIONS

1. How many bars are there on a full Calvert approach light system?
 - a. 5
 - b. 4
 - c. 3
 - d. 2

2. What length should the approach lighting system for a CAT I Calvert design be?
 - a. 900m.
 - b. 600m.
 - c. 1200m.
 - d. 400m.

3. What colour are runway end lights?
 - a. Unidirectional red.
 - b. Unidirectional white.
 - c. Omni directional red.
 - d. Omni directional white.

4. What is the colour of threshold lighting?
 - a. Omni directional green.
 - b. Uni-directional green, showing in the direction of the approach.
 - c. Uni-directional white, showing in the direction of the approach.
 - d. Red uni-directional.

5. On a Cat I lighting system, what is the length of the single, double and treble light segments on the centre-line of the approach lighting system?
 - a. 150m.
 - b. 200m.
 - c. 250m.
 - d. 300m.

6. What colour lights are runway edge lights, not including cautionary areas or pre-displaced thresholds?
 - a. White or yellow.
 - b. White.
 - c. Red.
 - d. Blue.

7. An aerodrome identification beacon on a land based aerodrome is:
 - a. blue.
 - b. white.
 - c. green.
 - d. red.

8. What colour is an aerodrome beacon for a land aerodrome?
- Flashing green.
 - Flashing green and white.
 - Steady green.
 - Flashing red.
9. What is the colour of threshold lights?
- Steady white.
 - Flashing white.
 - Steady green.
 - Flashing green.
10. What is the length of the approach lighting for a CAT I system?
- 300m.
 - 600m.
 - 900m.
 - 1200m.
11. What is a barrette?
- 3 or more single lights close together which appear at a distance to be a short bar.
 - Frangible approach lights.
 - Lead in lights.
 - Frangible lights.
12. When the lights of an aerodrome are required to be on (night-time etc.) they can only be switched off providing it is possible to switch them on:
- not more than 1 hour before the ETA of an arriving flight.
 - not more than 30 minutes before the ETA of an arriving flight.
 - not more than 5 minutes before the ETA of an arriving flight.
 - not more than 15 minutes before the ETA of an arriving flight.
13. Taxiway edge lights are:
- fixed showing blue.
 - fixed showing green.
 - fixed showing yellow.
 - flashing showing blue.
14. A precision approach Category I lighting system, the centreline and the barrette lights have to be:
- flashing green lights for which the intensity of the light is adjustable.
 - fixed white lights for which the intensity of the light is adjustable.
 - flashing white lights for which the intensity of the light is adjustable.
 - fixed green lights for which the intensity of the light is adjustable.

15. What defines a Calvert type runway approach lighting system?
- 3 crossbars with 3 lighting segments providing centreline lighting.
 - 3 crossbars with 2 lighting segments providing centreline lighting.
 - 5 Crossbars with 2 lighting segments providing centreline lighting.
 - 5 Crossbars with 3 lighting segments providing centreline lighting.
16. On the PAPI system the pilot can see, during the approach, two white lights furthest from the runway and two red lights closest to the runway. The aircraft is:
- under the approach glide path.
 - above the approach glide path.
 - precisely on the glide path.
 - on or close to the approach glide path.
17. The abbreviation "PAPI" stands for:
- Precision Approach Path Index.
 - Precision Approach Power Indicator.
 - Precision Approach Path Indicator.
 - Precision Approach Power Index.
18. What is the light indication of a land-based aerodrome beacon?
- Green alternating with white flashes or white flashes only.
 - White flashes only.
 - Green flashes only.
 - Same as an Aerodrome Identity Beacon.
19. Runway Guard lights are:
- flashing red.
 - flashing yellow.
 - flashing green.
 - steady red.

ANSWERS

Question	Answer	Reference
1.	A	21.12
2.	A	21.15
3.	A	21.24
4.	B	21.23
5.	D	21.15
6.	A	21.22
7.	C	21.10
8.	B	21.9
9.	C	21.23
10.	C	21.15
11.	A	21.13
12.	A	21.6
13.	A	21.29
14.	B	21.11
15.	D	21.12
16.	D	21.19
17.	C	21.18
18.	A	21.9
19.	B	21.32

CHAPTER TWENTY TWO

AERODROME SERVICES AND OBSTACLE MARKING

Contents

INTRODUCTION	411
VISUAL AIDS FOR DENOTING OBSTACLES	411
VISUAL AIDS FOR DENOTING RESTRICTED USE AREAS.	415
EMERGENCY AND OTHER SERVICES	416
OTHER AERODROME SERVICES.	417
QUESTIONS	420
ANSWERS	422

INTRODUCTION

22.1 The marking and/or lighting of obstacles is intended to reduce hazards to aircraft by indicating the presence of obstacles. It does not necessarily reduce operating limitations which may be imposed by obstacles. The responsibility for marking/lighting of obstacles on or near aerodromes must be determined between the aerodrome licensee and the owners of the structures. Licensees are responsible for the marking and lighting of all obstacles on the movement area irrespective of ownership. During the establishment of instrument approach and departure procedures, obstacles are identified to allow the calculation of operating minima and obstacle clearance height/altitude. The treatment of obstacles in this chapter is concerned with the identification and marking of obstacles on and in the vicinity of aerodromes, which may be collision hazards to local flying and en-route operations. Obstacles inside and outside the aerodrome boundary may result in limitations on the distance available for take-off and landing and on the range of meteorological conditions in which operations can be undertaken. For these reasons certain areas of local airspace must be regarded as integral parts of the aerodrome environment. The degree of freedom from obstacles in these areas is as important in the granting and retention of an aerodrome licence as the more obvious physical requirements of the runways and their associated runway strips.

22.2 Obstacle Identification Surfaces (OIS). Aerodrome obstacles are those obstacles that protrude through the OIS out to a distance of 15km from the aerodrome. The obstacles are determined by survey and are detailed in the aerodrome entry in the AIP. The OIS is a complex plane starting with the cleared strip either side of the runway. From the cleared strip, the inner transition plane extends from surface to 45m, and extends out to 3000m from the edges of the strip. Beyond this, the outer transition plane lifts the OIS to 150m and extends to the full 15km.

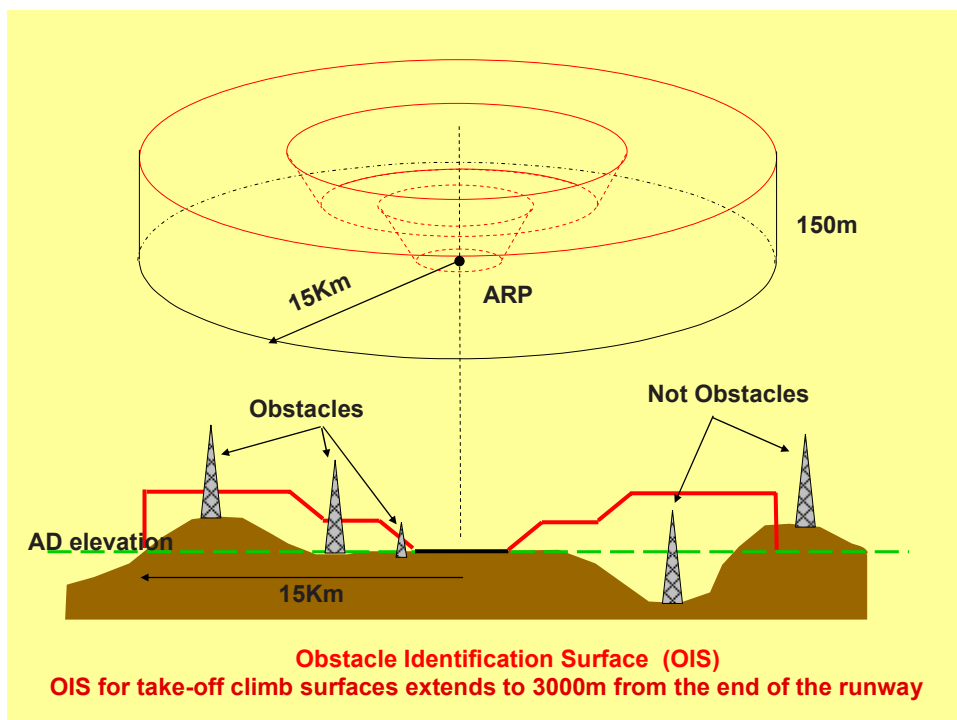

Figure 22.1: Obstacle identification surfaces (OIS).

VISUAL AIDS FOR DENOTING OBSTACLES

22.3 Requirement for marking/lighting. The marking and/or lighting of obstacles is intended to reduce hazards to aircraft by indicating the presence of the obstacles. Fixed obstacles should be marked and, if the aerodrome is used at night, lit. The marking may be omitted when the obstacle is lit by high intensity obstacle lights by day.

22.4 Obstacle on the Movement Area. Vehicles and other mobile objects excluding aircraft on the movement area of an aerodrome are obstacles and shall be marked and, if the vehicles and aerodrome are used at night or in conditions of low visibility, lit. Aircraft servicing equipment and vehicles used only on aprons may be exempt. Elevated aeronautical ground lights within the movement area shall be marked so as to be conspicuous by day.

22.5 Marking of objects. All fixed objects to be marked shall, whenever practicable, be coloured, but if this is not practicable, markers or flags shall be displayed on or above them. Orange or red colours should be used, except where such colours merge with the background. Against some backgrounds it may be found necessary to use a different colour from orange or red to obtain sufficient contrast.



Figure 22.2: Marking of objects.

22.6 Vehicles and Mobile Objects. When mobile objects are marked by colour, a single conspicuous colour, preferably red or yellowish green for emergency vehicles and yellow for service vehicles should be used. Aerodrome operators are responsible for ensuring that vehicles on the movement area of an aerodrome are lit and/or marked as required irrespective of ownership. These include maintenance vehicles, ATC vehicles, 'Follow Me' vehicles, aircraft towing vehicles, refuellers etc. Whenever a permitted vehicle is on the movement area the lights are to be switched on. Vehicle obstacle lights are low intensity flashing yellow. The lights specified are to be fitted at the highest point of the prime mover. Trailers are to be lit with low intensity steady red lights at the highest point. Objects with limited mobility (air bridges etc.) are to be lit with low intensity steady red lights.



Figure 22.3: Emergency vehicles.

22.7 Emergency Vehicles. Aerodrome ambulances, police/security, fire and rescue appliances should in addition to the requirements of paragraph 22.6 also carry blue flashing lights for use whilst responding to an emergency. Vehicles which are not normally based on the aerodrome (civilian fire/rescue vehicles) when called upon for assistance, are to show flashing blue lights and are to be escorted by vehicles with radio communication with ATC.

22.8 Lighting of objects. The presence of objects which must be lit shall be indicated by low, medium or high intensity obstacle lights, or a combination of such lights.

Note: High-intensity obstacle lights are intended for day use as well as night use.

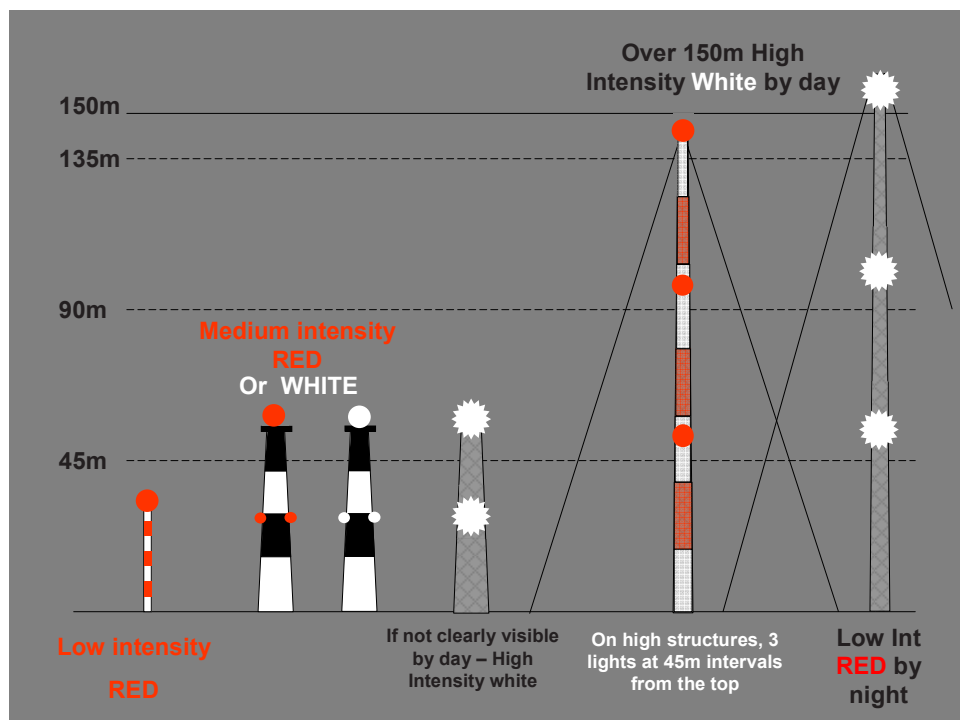

Figure 22.4: Methods of obstacle lighting.

22.9 Low Intensity Lights. Low-intensity obstacle lights on fixed objects shall be fixed red lights and have intensity sufficient to ensure conspicuity considering the intensity of the adjacent lights and the general level of illumination against which they would normally be viewed. Low intensity obstacle lights on objects with limited mobility such as aerobridges shall be steady-red. The intensity of the lights shall be sufficient to ensure conspicuity considering the intensity of the adjacent lights and the general levels of illumination against which they would normally be viewed. Where the use of low-intensity obstacle lights would be inadequate or an early special warning is required, then medium or high-intensity obstacle lights should be used.

22.10 Medium Intensity Lights. Medium-intensity obstacle lights shall be flashing red lights, except that when used in conjunction with high-intensity obstacle lights they shall be flashing white lights. The flash frequency shall be between 20 and 60 per minute. Medium intensity obstacle lights located on an object should flash simultaneously. Medium intensity obstacle lights should be used, either alone or in combination with low-intensity obstacle lights, where the object is an extensive one or its height above the level of the surrounding ground is greater than 45m.

22.11 High Intensity Lights. High intensity obstacle lights shall be flashing white lights. High intensity obstacle lights, located on an object should flash simultaneously at a rate between 40 and 60 per minute. High-intensity obstacle lights, located on a tower should flash sequentially; first the middle light, second the top light and last the bottom light. High intensity obstacle lights should be used to indicate the presence of an object if its height above the level of the surrounding ground exceeds 150m and an aeronautical study indicates such lights to be essential for the recognition of the object by day.

22.12 Tall Objects. Where an object is indicated by low or medium intensity obstacle lights, and the top of the object is more than 45m above the level of the surrounding ground or the elevation of tops of nearby buildings (when the object to be marked is surrounded by buildings) additional lights shall be provided at intermediate levels. These additional intermediate lights shall be spaced as equally as practicable, between the top lights and ground level or the level of tops of nearby buildings, as appropriate, with the spacing not exceeding 45m.



Figure 22.5: Tall objects.

22.13 Lighting of Aircraft. The lighting of aircraft is detailed at Chapter 6 Rules of the Air. This subject is covered in detail in the OP syllabus. It should be noted that aircraft parked on the manoeuvring area are obstacles and should be lit either by the aircraft navigation lights or by ancillary lighting (anti-collision) that determines the extremities of the aeroplane.

22.14 En-route Obstacles. Objects located beyond 15 km radius of the aerodrome are normally considered to be obstacles to aircraft in flight only if they exceed 150 m in height. Prominent objects of less height may be regarded as obstacles if they are on or adjacent to routes regularly used by helicopters. En-route obstacles are usually lit by steady red lights at night and high intensity flashing white lights by day. Environmental considerations may preclude the use of high intensity lights.

VISUAL AIDS FOR DENOTING RESTRICTED USE AREAS

22.15 Closed runways and taxiways. A 'closed' marking shall be displayed on a runway or taxiway, or portion thereof, which is permanently closed to the use of all aircraft. A closed marking should be displayed on a temporarily closed runway or taxiway or portion thereof, except when the closing is of short duration and adequate warning by air traffic services is provided. On a runway a 'closed' marking shall be placed at each end of the runway, or portion thereof, declared closed, and additional markings shall be so placed that the maximum interval between markings does not exceed 300m. On a taxiway a closed marking shall be placed at least at each end of the taxiway or portion thereof closed. The marking shall be white when displayed on a runway and shall be yellow when displayed on a taxiway. (Note: When an area is temporarily closed, frangible barriers or markings utilizing materials other than paint or other suitable means may be used to identify the closed area). When a runway or taxiway or portion thereof is permanently closed, all normal runway and taxiway markings shall be obliterated. Lightings on a closed runway or taxiway or portion thereof shall not be operated, except as required for maintenance purposes.



Figure 22.6: Closed runway.

22.16 Non-load bearing surfaces. Shoulders for taxiways, holding bays and aprons and other non-load bearing surfaces which cannot readily be distinguished from load-bearing surfaces and which, if used by aircraft, might result in damage to the aircraft shall have the boundary between such areas and the load bearing surface marked by a taxi side stripe marking.

22.17 Pre-threshold area. When the surface before a threshold is paved and exceeds 60m in length and is not suitable for normal use by aircraft, the entire length before the threshold should be marked with a chevron marking. The chevron marking should point in the direction of the runway.

EMERGENCY AND OTHER SERVICES

22.18 Rescue and Fire Fighting (RFF). The principal objective of a RFF service is to save lives. For this reason, the provision of means of dealing with an aircraft accident or incident occurring at, or in the immediate vicinity of, an aerodrome assumes primary importance because it is within this area that there are the greatest opportunities of saving lives. This must assume at all times the possibility of, and need for, extinguishing a fire which may occur either immediately following an aircraft accident or incident, or at any time during rescue operations. The most important factors bearing on effective rescue in a survivable aircraft accident are: the training received, the effectiveness of the equipment and the speed with which personnel and equipment designated for rescue and fire fighting purposes can be put into use. Requirements to combat building and fuel farm fires, or to deal with foaming of runways, are not taken into account. Public or private organisations, suitably located and equipped, may be designated to provide the RFF service. It is intended that the fire station housing these organisations be normally located on the aerodrome, although an off aerodrome location is not precluded provided the response time can be met.

22.19 Level of protection to be provided. The level of protection provided at an aerodrome for RFF shall be appropriate to the aerodrome category. Exceptionally, where the number of movements of the aeroplanes in the highest category normally using the aerodrome is less than 700 in the busiest consecutive three months, the level of protection provided may be (from 1 January 2000) not less than one category below the determined category. The aerodrome category shall be determined from the table below, based on the longest aeroplanes normally using the aerodrome and fuselage width. If, after selecting the category appropriate to the longest aeroplane's over-all length that aeroplanes fuselage width is greater than the maximum width for that category then one category higher is used. During anticipated periods of reduced activity, the level of protection available must be no less than that needed for the highest category of aeroplane planned to use the aerodrome during that time irrespective of the number of movements.

Category	Aeroplane Overall Length	Maximum Fuselage Width
1	0m up to but not including 9m	2m
2	9m up to but not including 12m	2m
3	12m up to but not including 18m	3m
4	18m up to but not including 24m	4m
5	24m up to but not including 28m	4m
6	28m up to but not including 39m	5m
7	39m up to but not including 49m	5m
8	49m up to but not including 61m	7m
9	61m up to but not including 76m	7m
10	76m up to but not including 90m	8m

Figure 22.7: RFF categories.

22.20 Response time. The operational objective of the RFF service should be to achieve response times of two minutes, and not exceeding three minutes, to the end of each runway, as well as to any other part of the movement area, in optimum conditions of visibility and surface conditions. Response time is considered to be the time between the initial call to the RFF service, and the time when the first responding vehicle is in position to apply foam at a rate of at least 50% of the discharge rate specified. To meet the operational objective as nearly as possible in less than optimum conditions of visibility it may be necessary to provide guidance for RFF vehicles.

22.21 Emergency access roads. Emergency access roads should be provided on an aerodrome where terrain conditions permit their construction, so as to facilitate achieving minimum response times. Particular attention should be given to the provision of ready access to approach areas up to 1,000m from the threshold, or at least within the aerodrome boundary. Where a fence is provided, the need for convenient access to outside areas should be taken into account. Note: Aerodrome service roads may serve as emergency access roads when they are suitable located and constructed.

22.22 Fire stations. All RFF vehicles should normally be housed in a fire station. Satellite fire stations should be provided whenever the response time cannot be achieved from a single fire station. The fire station should be located so that the access for RFF vehicles into the runway area is direct and clear, requiring a minimum number of turns. Providing the response time (22.20) can be met, the fire station need not be within the aerodrome confines.

OTHER AERODROME SERVICES

22.23 Apron Management Service. When warranted by the volume of traffic and operating conditions, an appropriate Apron Management Service (not to be confused with Ground Control), should be provided on an apron by an aerodrome ATS unit, by the aerodrome operating authority, or by a co-operative combination of these. Commercial operations providing the Apron Management Service also provide refuelling, de-icing, baggage and cargo handling and passenger transportation where busses are used. When the aerodrome control tower does not participate in the apron management service, procedures should be established to facilitate the orderly transition of aircraft between the apron management unit and the aerodrome control tower. Typically, when the flight is ready to depart, the pilot will call Ground Control and request engine start. This serves not only as a request to actually start the engines, but also to notify ATC that administratively and from an engineering point of view, the flight is ready to commence. At this point the tug would be coupled to the aeroplane and the 'crew chief' would be on external intercom. The pilot would then request "push back" and when approved the aircraft will move out on to the taxiway. At the same time the engines will be started and when the flight deck crew is satisfied that all if well, the tug will be disconnected and the nose-wheel steering reconnected. When this has been completed the crew chief will confirm that all panels are secure and that he is now unplugging his intercom lead. An apron management service shall be provided with radiotelephony communications facilities. Where low visibility procedures are in effect, persons and vehicles operating on an apron shall be restricted to the essential minimum. An aircraft stand shall be visually monitored to ensure that the recommended clearance distances are provided to an aircraft using the stand. The purpose of the apron management service is to:

- Regulate movement with the objective of preventing collisions between aircraft, and between aircraft and obstacles;
- Regulate entry of aircraft into, and co-ordinate exit of aircraft from, the apron with the aerodrome control tower, and

- Ensure safe and expeditious movement of vehicles and appropriate regulation of other activities.

22.24 Emergency Vehicles. An emergency vehicle responding to an emergency shall be given priority over all other surface movement traffic. A vehicle operating on an apron shall:

- Give way to an emergency vehicle; an aircraft taxiing, about to taxi, or being pushed or towed, and
- Give way to other vehicles in accordance with local regulations.

22.25 Ground servicing to aircraft. Fire extinguishing equipment suitable for at least initial intervention in the event of a fuel fire and personnel trained in its use shall be readily available during the ground servicing of an aircraft, and there shall be a means of quickly summoning the rescue and fire fighting service in the event of a fire or major fuel spill. When aircraft refuelling operations take place while passengers are embarking, on board or disembarking, ground equipment shall be positioned so as to allow:

- The use of sufficient number of exits for expeditious evacuation, and
- A ready escape route from each of the exits to be used in an emergency.

QUESTIONS

1. What is the colour of a low intensity obstacle light?
 - a. Blue.
 - b. Steady red.
 - c. Yellow.
 - d. Flashing red.

2. Low intensity obstruction lights on fixed objects and slow moving objects are:
 - a. flashing green.
 - b. flashing yellow.
 - c. steady red.
 - d. steady blue.

3. Medium intensity obstacle lighting will normally consist of flashing red lights except that they may be flashing white when used:
 - a. in conjunction with high-intensity obstacle lighting.
 - b. in conjunction with low-intensity obstacle lighting.
 - c. in conjunction with runway obstacle lighting.
 - d. in conjunction with the approach path obstacle lighting.

4. OIS stands for:
 - a. Obstacle Interference Slope.
 - b. Obstacle Identification Surface.
 - c. Obstacle Inner Surface.
 - d. Obstacle Identification Slope.

5. What colour lights are vehicles moving routinely on the aerodrome required to show?
 - a. Flashing yellow.
 - b. Flashing red.
 - c. Flashing blue.
 - d. Steady red.

6. What colour are emergency vehicles painted that are used on the manoeuvring area of an aerodrome?
 - a. Green.
 - b. Dayglo orange.
 - c. A single conspicuous colour, preferably red or yellowish green.
 - d. White and red chequered.

7. An en-route obstacle is located:
 - a. within 15 kms radius of an aerodrome.
 - b. outside 5 nms from the boundary of any controlled airspace.
 - c. beyond 15 kms radius of an aerodrome.
 - d. in any location that might be encountered during the cruise phase of a flight.

8. An object of limited mobility (an air bridge for example) is lit by:
 - a. low intensity steady red lights.
 - b. low intensity flashing red lights.
 - c. medium intensity steady red lights.
 - d. medium intensity flashing red lights.

9. Must an aerodrome fire station be located within the confines of an aerodrome?
 - a. No, providing the response time can be met.
 - b. Yes.
 - c. No.
 - d. No, providing it is within 3 minutes driving time of the aerodrome.

10. The level of rescue and fire fighting (RFF) facilities is dependent upon the category of the aerodrome. What factors determine this category?
 - a. Aeroplane reference field length, wing span and outer main gear wheel span of the largest aircraft using that aerodrome.
 - b. The length of the longest runway and the area to be covered.
 - c. The overall length and the fuselage width of the longest aircraft normally using that aerodrome.
 - d. The length of the longest runway and total area of hard standings (including access roads).

11. The aerodrome category for RFF is based on:
 - a. the overall length of the longest aeroplane.
 - b. the longest aeroplane maximum width only.
 - c. the overall length of the longest aeroplane normally using the aerodrome and its maximum fuselage width.
 - d. the overall length of the longest aeroplane normally using the aerodrome and its maximum fuselage weight.

12. High Intensity Obstacle lights should be:
 - a. flashing white.
 - b. flashing red.
 - c. fixed red.
 - d. fixed orange.

ANSWERS

Question	Answer	Reference
1.	B	22.9
2.	C	22.9
3.	A	22.10
4.	B	22.2
5.	A	22.6
6.	C	22.6
7.	C	22.2
8.	A	22.6
9.	A	22.22
10.	C	22.19
11.	C	22.19
12.	A	22.11

CHAPTER TWENTY THREE

FACILITATION

Contents

AIM	425
ENTRY AND DEPARTURE OF AIRCRAFT.	425
QUESTIONS	429
ANSWERS	430

AIM

23.1 Article 37. The Standards and Recommended Practices on Facilitation contained in Annex 9, are the outcome of Article 37 of the Convention, which provides that the “International Civil Aviation Organisation shall adopt and amend from time to time, as may be necessary, international standards and recommended practices and procedures dealing with customs and immigration procedures and other matters concerned with the safety, regularity and efficiency of air navigation as may from time to time appear appropriate”. The policy with respect to the implementation by States of the Standards and Recommended Practices on Facilitation is strengthened by Article 22 of the Convention, which expresses the obligation accepted by each Contracting State “to adopt all practicable measures, through the issuance of special regulations or otherwise, to facilitate and expedite navigation by aircraft between the territories of Contracting States, and to prevent unnecessary delays to aircraft, crews, passengers, and cargo, especially in the administration of the laws relating to immigration, quarantine, customs and clearance”, and by Article 23 of the Convention, which expresses the undertaking of each Contracting State “so far as it may find practicable, to establish customs and immigration procedures affecting international air navigation in accordance with the practices which may be established or recommended from time to time pursuant to this Convention”.

23.2 Documentation. The documentation required by States for the entry and departure of aircraft, crew and passengers have evolved from the same documentation required for shipping and much of the terminology has been retained. The rapid movement of aircraft and the philosophy of expediting the movement of aircraft, has led to procedures where the old documents are now out of date and where still necessary, have been replaced by electronic data systems and digital transmission systems.

ENTRY AND DEPARTURE OF AIRCRAFT

23.3 General. Government regulations and procedures applicable to the clearance of aircraft shall be no less favourable than those applied to other forms of transportation. Contracting States shall adopt procedures for the clearance of aircraft, including those normally applied for aviation security purposes, as well as those appropriate for narcotics control, which will be applied and carried out in such a manner as to retain the advantage of speed inherent in air transport.

23.4 Documents. No documents other than those provided for in Annex 9, shall be required by the public authorities from operators for the entry and departure of aircraft. Where a Contracting State introduces electronic data interchange (EDI) techniques for a clearance function, authorities should also execute a plan for migration to complete reliance on the electronic system for the exchange of required information with a view towards phasing out the requirement for preparation and exchange of paper documents. If a state permits a traveller to enter that state without a visa (i.e. under the US visa waiver scheme) the state of departure will not require the traveller to obtain any other document relating to the traveller’s identity other than the passport.

23.5 General Declaration. A general declaration is an internationally recognised form which contains details of the aircraft (Registration Mark and nationality) the flight number, date and place of departure, and destination. It also contains details of the flight routing and the number of crew and passengers boarding and disembarking at the various locations. It contains a health declaration and a certificate signed by the PIC or an authorised agent. It is the eventual aim to eliminate from the general declaration, any reference to passengers. Contracting States will not require the presentation of the General Declaration when this information can be readily obtained in an alternative and acceptable manner.

A Contracting State which continues to require the presentation of the General Declaration shall accept it when signed by either the authorised agent or the pilot-in-command, but may, when necessary, require the health section thereof to be signed by a crew member when the General Declaration itself has been signed by a non-crew member. Where Contracting States require the presentation on entry and departure of aircraft of information relating to crew members, such information shall be limited to the number of crew on board. Where the General Declaration continues to be required, this information shall be provided in the column headed "Total number of crew".



General Declaration
***Outward/Inward**

C155

Operator

Marks of nationality and registration Flight prefix and number Date

Departure from Arrival at

(Place) (Place)

Flight Routing

("Place" column always to list origin, every en-route stop and destination)

Place	Total number of crew	Number of passengers on this stage
.....	Departure Place:
.....	Embarking
.....	Through on same flight
.....	Arrival Place:
.....	Disembarking
.....	Through on same flight

Declaration of Health

Persons on board with illnesses other than airsickness or the effects of accidents (including persons with symptoms or signs of illness such as rash, fever, chills, diarrhoea) as well as those cases of illness disembarked during the flight.

.....

.....

Any other conditions on board which may lead to the spread of disease

.....

.....

Details of each disinsecting or sanitary treatment (place, date, time, method) during the flight. If no disinsecting has been carried out during the flight give details of most recent disinsecting.

.....

.....

Signed if required
Crew member concerned

For official use

I declare that all statements and particulars contained in this General Declaration, and in any supplementary forms required to be presented with this General Declaration are complete, exact and true to the best of my knowledge and that all through passengers *"will continue/have continued"* on this flight

Signature
Authorised agent or Pilot-in-command

Further supplies of this form can be obtained from any Collector of Customs and Excise

**Delete as necessary*

Data Protection Act 1998

HM Customs and Excise collects information in order to administer the taxes for which it is responsible (such as VAT, insurance premium tax, excise duties, air passenger duty, landfill tax), and for detecting and preventing crime.

Where the law permits we may also get information about you from third parties, or give information to them, for example in order to check its accuracy, prevent or detect crime or protect public funds in other ways. These third parties may include the police, other government departments and agencies.

C155

PT (January 2001)

Figure 23.1: General declaration.

23.6 Manifests. In addition to the General Declaration, Passenger and Cargo manifests are additional internationally recognised documents that detail names of passengers and the nature of goods embarked on the aeroplane. When a Contracting State has eliminated the Passenger Manifest and no longer requires the General Declaration (except for purposes of attestation) it shall accept, at the option of the operator, either a General Declaration or an appropriate attestation, signed by the authorised agent or pilot-in-command, on one page only of the Cargo Manifest. The attestation on the Cargo Manifest can be provided by means of a rubber stamp.

23.7 Passenger Baggage. Contracting States shall not require the presentation of a list of the number of pieces of accompanied baggage. Operators carrying baggage shall, upon request from the authorities, provide them with any available information where it is not otherwise been provided for customs clearance purposes by the passenger.

23.8 Oral Declaration. An oral (spoken) declaration is acceptable concerning the content of crew and passenger baggage. A random inspection of baggage is acceptable.

23.9 Completion of Documents. Documents may be typewritten, produced in electronic data form or handwritten in ink or indelible pencil, providing it is in a legible form.

23.10 Advanced Notification of Arrival. Where non-schedule flights are made by an aircraft registered in an ICAO contracting state which wish to land in another contracting state for non traffic purposes (2nd freedom flight), the submission of a flight plan is considered sufficient advanced notification to the State of Landing that the flight is to be conducted. However, the authority of State of Landing will accept that flight providing the flight plan is received at least two hours in advance of the arrival and that landing occurs at a previously designated international airport. Where such addressees are required to be notified (customs, immigration, police etc.) the flight plan is to be addressed to the appropriate authorities of the state concerned.

23.11 Crew and other Operators' Personnel. Contracting States shall ensure that when inspection of crew members and their baggage is required on arrival or departure, such inspection shall be carried out as expeditiously as possible. Contracting States shall provide facilities which will enable crew members of their airlines to obtain without delay and without charge, crew members' certificates (CMC), valid for the crew members' term of employment.

Note: The CMC was developed as a card for use for identification purposes by both flight crew and cabin attendants, leaving the crew licences to serve their primary purpose of attesting to the professional qualifications of the flight crew.

In the case of airline flight crew and cabin attendants who retain their crew member certificates in their possession when embarking and disembarking, remain at the airport where the aircraft has stopped or within the confines of cities adjacent thereto, and depart on the same aircraft or their next regularly scheduled flight, each. Contracting State shall accept a crew member certificates for temporary admission to the State and shall not require a passport or visa.

Note 1: It is the intent of this provision that a crew member certificate shall be recognized as a satisfactory identity document even if the holder is not a national of the State of Registry of the aircraft on which he serves. It is not desired to discourage Contracting States from issuing such crew member certificates to resident alien crew members if they are willing to do so.

Note 2: The implementation of this permits rapid and efficient disposition of personnel by airlines. The full benefit cannot be derived from these provisions while some States withhold acceptance of them.

23.12 Non-scheduled Operations. Each Contracting State shall extend privileges of temporary admission to flight crew and cabin attendants of an aircraft operated for remuneration or hire but not engaged in scheduled international air services, subject to the requirement that such flight crew and cabin attendants must depart on the aircraft on its first flight out of the territory of the State.

QUESTIONS

1. The documents which allow an aircraft entry to a country:
 - a. must be typewritten.
 - b. can be hand-written in block capitals in ink or indelible pencil.
 - c. are accepted at the discretion of the state of arrival.
 - d. must be typewritten or sent in electronic data format.

2. Can an oral declaration concerning the passenger or crew baggage be acceptable?
 - a. Never.
 - b. Yes.
 - c. Only crew baggage.
 - d. Only passenger baggage.

3. The General Declaration is signed by the:
 - a. the Pilot in Command only.
 - b. the Pilot in Command or the Agent.
 - c. any flight crew member.
 - d. the Operator.

4. Where an aircraft registered in a contracting state is making a flight over foreign territory for non commercial purposes or is landing for non traffic purposes, advanced notification is to be given to the foreign state. The information is to be received:
 - a. at least 2 hours in advance of arrival.
 - b. at least 4 hours in advance of arrival.
 - c. at least 1 hour in advance of arrival.
 - d. at least 12 hours in advance of the planned ETA.

5. The ICAO Annex which deals with the entry and departure of persons and their baggage for international flights is:
 - a. Annex 6.
 - b. Annex 15.
 - c. Annex 9.
 - d. Annex 8.

6. In cases where a visitor travelling by air holds a valid passport and no visa is required of him, contracting states:
 - a. shall not require the traveller to obtain any other identity document before boarding the aeroplane.
 - b. may require the traveller to obtain any other identity document before boarding the aeroplane.
 - c. in certain cases may require additional identification documents.
 - d. none of the above answers is correct.

ANSWERS

Question	Answer	Reference
1.	B	23.9
2.	B	23.8
3.	B	23.5
4.	A	23.10
5.	C	23.1
6.	A	23.4

CHAPTER TWENTY FOUR

SEARCH AND RESCUE

Contents

DEFINITIONS AND ABBREVIATIONS	433
ESTABLISHMENT AND PROVISION OF SAR SERVICE	433
CO-OPERATION BETWEEN STATES	434
OPERATING PROCEDURES	434
QUESTIONS	438
ANSWERS	440

DEFINITIONS AND ABBREVIATIONS

24.1 Definitions. The following definitions are required knowledge.

Item	Definition
Alert phase	A situation wherein apprehension exists as to the safety of an aircraft and its occupants.
Distress phase	A situation wherein there is a reasonable certainty that an aircraft and its occupants are threatened by grave and imminent danger or require immediate assistance.
Emergency phase	A generic term meaning, as the case may be, uncertainty phase, alert phase or distress phase.
Operator	A person, organisation or enterprise engaged in or offering to engage in an aircraft operation.
Pilot-in-command (PIC)	The pilot responsible for the operation and safety of the aircraft during flight time.
Rescue co-ordination centre (RCC)	A unit responsible for promoting efficient organisation of SAR service and for co-ordinating the conduct of SAR operations within a SAR region.
State of Registry	The State on whose register the aircraft is entered.
Uncertainty phase	A situation wherein uncertainty exists as to the safety of an aircraft and its occupants.

ESTABLISHMENT AND PROVISION OF SAR SERVICE

24.2 Basis of Establishment. Contracting States shall arrange for the establishment and provision of SAR services within their territories. Such services shall be provided on a 24 hour basis. In providing assistance to aircraft in distress and to survivors of aircraft accidents, Contracting States shall do so regardless of the nationality of such aircraft or survivors.

24.3 Establishment of SAR Regions. Contracting States shall delineate the SAR regions within which they will provide SAR service. Such regions shall not overlap. Boundaries of SAR regions should, in so far as is reasonably practicable, be coincident with the boundaries of corresponding flight information regions.

24.4 Establishment and Designation of SAR Service Units. Contracting States shall establish a rescue co-ordination centre (RCC) in each SAR region. Contracting States should establish rescue sub-centres whenever this would improve the efficiency of SAR services. The organisation of SAR services is the responsibility of the RCC and any sub centres established. In areas where public telecommunications facilities would not permit persons observing an aircraft in emergency to notify the rescue co-ordination centre concerned directly and promptly, Contracting States should designate suitable units of public or private services as alerting posts.

CO-OPERATION BETWEEN STATES.

24.5 Requirement. Contracting States shall co-ordinate their SAR organisations with those of neighbouring Contracting States. Contracting States should, in so far as practicable, develop common SAR procedures to facilitate co-ordination of SAR operations with those of neighbouring States. Subject to such conditions as may be prescribed by its own authorities, a Contracting State shall permit immediate entry into its territory of rescue units of other States for the purpose of searching for the site of aircraft incidents and rescuing survivors of such accidents. The authorities of a Contracting State which wishes its rescue units to enter the territory of another Contracting State for SAR purposes shall transmit a request, giving full details of the projected mission and the need for it, to the rescue co-ordination centre of the State concerned or to such other authority as has been designated by that State. The authorities of Contracting States shall:

- Immediately acknowledge the receipt of such a request, and
- As soon as possible indicate the conditions, if any, under which the projected mission may be undertaken;

24.6 Agreement with Other States. Contracting States should enter into agreements with neighbouring States setting forth the conditions for entry of each others rescue units into their respective territories. These agreements should also provide for expediting entry of such units with the least possible formalities. Each Contracting State should authorise its rescue co-ordination centres to:

- request from other rescue co-ordination centres such assistance, including aircraft, vessels, personnel or equipment, as may be needed;
- grant any necessary permission for the entry of such aircraft, vessels, personnel or equipment into its territory; and
- make the necessary arrangements with the appropriate customs, immigration or other authorities with a view to expediting such entry.

24.7 Assistance to Other States. Each Contracting State should authorise its rescue co-ordination centres to provide, when requested, assistance to other rescue co-ordination centres, including assistance in the form of aircraft, vessels, personnel or equipment.

OPERATING PROCEDURES

24.8 Information Concerning Emergencies. Contracting States should encourage any person observing an accident or having reason to believe that an aircraft is in an emergency to give immediately all available information to the appropriate alerting post or to the rescue co-ordination centre concerned. Any authority or any element of the SAR organisation having reason to believe that an aircraft is in an emergency shall give immediately all available information to the rescue co-ordination centre concerned. Rescue co-ordination centres shall, immediately upon receipt of information concerning aircraft in emergency, evaluate such information and determine the extent of the operation required. When information concerning aircraft in emergency is received from other sources than air traffic service units, the rescue co-ordination centre shall determine to which emergency phase the situation corresponds and shall apply the procedures applicable to that phase.

24.9 First Aircraft on Scene. If the first aircraft to reach the scene of an accident is not a SAR aircraft the PIC of that aircraft shall take charge of on-scene activities of all other aircraft subsequently arriving until the first dedicated SAR aircraft reaches the scene of the accident. If, in the meantime, the aircraft is unable to establish communication with the appropriate rescue co-ordination centre or air traffic services unit, it shall, by mutual agreement, hand over to an aircraft capable of establishing and maintaining such communications until the arrival of the first SAR aircraft.



© Ian Older

Figure 24.1: RAF Nimrod MR2A used for long range SAR.

24.10 Direction of Surface Craft. When it is necessary for an aircraft to direct a surface craft to the place where an aircraft or surface craft is in distress, the aircraft shall do so by transmitting precise instructions by any means at its disposal. All ships at sea maintain a radio watch on the HF Maritime Distress and calling frequency 2 182 Khz (2.182 Mhz). In coastal waters, all shipping maintains a watch on VHF FM Chan 16. Aircraft do not normally carry VHF FM transmitters but may be able to relay through Coast Guard units or coastal radio stations. If no radio communication can be established the aircraft shall use the appropriate signal to attract the attention of the vessel. If the PIC can identify the vessel by name and port of registration (painted on the stern), the RCC can pass messages to the vessel through the maritime communications system.

24.11 Communication with Survivors. When it is necessary for an aircraft to convey information to survivors or surface rescue units, and two way communication is not available, it shall, if practicable, drop communication equipment that would enable direct contact to be established, or convey the information by dropping the message. When a ground signal has been displayed, the aircraft shall indicate whether the signal has been understood or not, or if this is not practicable, by use of the appropriate signal.

24.12 Signals with Surface Aircraft The following manoeuvres performed in sequence by an aircraft mean that the aircraft wishes to direct a surface craft towards an aircraft or a surface craft in distress (repetition of such manoeuvres has the same meaning):

- Circling the surface craft at least once
- Crossing the projected course of the surface craft close ahead at low altitude and:
 - Rocking the wings; or
 - Opening and closing the throttle; or
 - Changing the propeller pitch.
- Heading in the direction in which the surface craft is to be directed.

24.13 Assistance No Longer Required. If assistance is no longer required by an aircraft, the aircraft should indicate the fact by crossing the wake of the surface craft close astern at a low altitude and rocking the wings; or opening and closing the throttle; or changing the propeller pitch.

24.14 SAR Signals. The signals detailed below shall when used, have the meaning indicated therein. They shall be used only for the purpose indicated and no other signals likely to be confused with them shall be used. Upon observing any of the signals, aircraft shall take such action as may be required by the interpretation of the signal.

24.15 Ground-Air Visual Signal Code. In order to communicate basic messages and instructions from ground parties to aircraft, an internationally agreed system of signals has been established. There are two sets: Signals from crash survivors; signals from search teams.

24.16 Ground Air Visual Signal Code for Use by Survivors. The following signals may be set out in some form (marked in snow, oil on sand, burned grass in open areas) to ask for help.

	Message	Symbol
1	Require assistance	V
2	Require medical assistance	X
3	No (negative)	N
4	Yes (affirm)	Y
5	Proceeding in this direction	→

Figure 24.2: Ground/Air signals from survivors.

24.17 Air to Ground Signals. To indicate that the ground signals have been understood (lack of the signal indicates that the ground signal is not understood), during the hours of daylight rock the aircraft's wings; during the normal hours of darkness, flashing on and off twice the aircraft's landing lights or, if not so equipped, by switching on and off twice its navigation lights.

QUESTIONS

1. If you observe a distress light on the ground at night, you should:
 - a. flash landing lights or navigation lights twice.
 - b. fly over as low as possible then flash lights.
 - c. fly in circles above then flash lights.
 - d. fly a triangular pattern.

2. What does the SAR signal "X" on the ground mean?
 - a. We need help.
 - b. We are OK.
 - c. We need medical assistance.
 - d. We have gone away.

3. Aircraft No1 is the first aircraft at the scene of a SAR incident but has no means of contacting the RCC, but No 2 aircraft does and arrives shortly afterwards. Finally No 3 aircraft (a specialist SAR aircraft) arrives on the scene. What is the transfer of command sequence?
 - a. No 1 assumes command throughout.
 - b. No 1, followed by No 2, followed by No 3.
 - c. No 1, then by discretion (or handover to) No 2, finally No 3 on arrival.
 - d. No 3 only.

4. For what period are SAR services to be provided by a Contracting State?
 - a. During the hours of operation of an FIR.
 - b. On a 24 hour basis.
 - c. 2 hours before until 2 hours after the first flight arrives and the last departing flight within an FIR.
 - d. During the hours of both commercial and military air operations within the FIR.

5. Three aircraft are at the scene of an accident. Aircraft 1 arrives first but cannot contact ATC. Aircraft 2 arrives second and has good communications with ATC. Aircraft 3 arrives last and is an SAR aircraft. Who assumes responsibility?
 - a. Aircraft 1 and 2 wait for aircraft 3 to arrive.
 - b. Aircraft 2 because he has good communications with ATC.
 - c. Aircraft 2 until aircraft 3 arrives.
 - d. Aircraft 1 until aircraft 2 arrives who then passes control to aircraft.

6. Which of the following means 'Require assistance'?
 - a. Y
 - b. X
 - c. R
 - d. V

7. When sighting a distress flare during daytime, you should:
 - a. circle once.
 - b. flash landing lights or navigation lights.
 - c. rock wings.
 - d. send the letter 'R' in Morse by lights to the downed aircraft.

8. Who is responsible for the organisation of an efficient SAR service?
 - a. FIC and RCC.
 - b. RCC and rescue sub-centres.
 - c. FIC, RCC and ACC.
 - d. ICAO through regional navigation plans.

9. What does the SAR ground signal ">" mean?
 - a. We have gone south.
 - b. We need assistance.
 - c. We need medical assistance.
 - d. Yes.

ANSWERS

Question	Answer	Reference
1.	A	24.17
2.	C	24.16
3.	C	24.9
4.	B	24.2
5.	D	24.9
6.	D	24.16
7.	C	24.17
8.	B	24.4
9.	B	24.16

CHAPTER TWENTY FIVE

SECURITY

Contents

INTRODUCTION	443
OBJECTIVES	443
ORGANISATION	444
PREVENTATIVE SECURITY MEASURES.	444
MANAGEMENT OF RESPONSE TO ACTS OF UNLAWFUL INTERFERENCE.	445
FURTHER SECURITY INFORMATION.	446
QUESTIONS	450
ANSWERS	454

INTRODUCTION

Definitions. The following definitions are examinable:

Item	Definition
Airside	The movement area of an airport, adjacent terrain and buildings or portions thereof, access to which is controlled (used to be called 'the aeronautical part').
Screening	The application of technical or other means which are intended to identify and/or detect weapons, explosives or other dangerous devices, articles or substances which may be used to commit an act of unlawful interference.
Security	Safeguarding civil aviation against acts of unlawful interference. This objective is achieved by a combination of measures and human and material resources.
Security restricted area	Those areas of the airside of an airport which are identified as priority risk areas where in addition to access control, other security controls are applied. Such areas will normally include all commercial aviation passenger departure areas between the screening point and the aircraft, the ramp, baggage make-up areas, including those where aircraft are being brought into service and screened baggage and cargo are present, cargo sheds, mail centres, airside catering and aircraft cleaning premises.
Unidentified baggage	Baggage at an airport with or without a baggage tag, which is not picked up by or identified with a passenger.

25.1 Annex 17. The Annex to the Chicago which contains the SARPs for Security is Annex 17. Information applicable to the implementation of security policy is also contained in other ICAO publications and the attention of students is drawn to paragraph 25.5 for revision.

OBJECTIVES

25.2 General. The aim of aviation security shall be to safeguard international civil aviation operations against acts of unlawful interference. Safety of passengers, crew, ground personnel and the general public shall be the primary objective of each Contracting State in all matters related to safeguarding against acts of unlawful interference with international civil aviation.

25.3 Organisation. Each Contracting State shall establish an organisation, develop plans and implement procedures, which together provide a standardized level of security for the operation of international flights in normal operating conditions and which are capable of rapid expansion to meet any increased security threat.

25.4 Facilitation. Each Contracting State should whenever possible arrange for the security measures and procedures to cause a minimum of interference with, or delay to the activities of, international civil aviation.

ORGANISATION

25.5 National Organisation. Each Contracting State shall establish a national civil aviation security programme the objective of which will be to safeguard international civil aviation operations against unlawful interference, through regulations, practices and procedures which take account of the safety, regularity and efficiency of flights. This will include the designation of an appropriate authority to co-ordinate all security activities, to implement the security programme, to ensure the programme meets the needs of international traffic, to establish airport security committees, to ensure that contingency plans are in place for acts of unlawful interference, and to ensure training programmes are implemented. The programme may be extended to cover domestic air service. A copy of the programme is to be given to ICAO.

25.6 Airport Design. The state is required to ensure that airport design requirements, including architectural and infrastructure related requirements necessary for the implementation of security measures are integrated into the design and construction of new facilities and alterations to existing facilities at airports.

25.7 International Co-operation. The most effective means of combating international terrorism is to act within a co-ordinated framework and to common standards. Each contracting state is therefore required to co-operate with other States in order to adapt their respective national civil aviation security programmes as necessary; to make available to other States on request a written version of the appropriate parts of its national civil aviation security programme; to include in its bilateral agreements on air transport, a clause related to aviation security; to ensure that requests from other states for special security measures in respect of a specific flight or specified flights by operators of such other States, as far as may be practicable, are met; to co-operate with each other in the development and exchange of information concerning training programmes; and to co-operate with other States in the field of research and development of new security equipment which will better satisfy international civil aviation security objectives.

PREVENTATIVE SECURITY MEASURES.

25.8 Prohibited Objects. Each contracting state shall establish measures to prevent weapons, explosives or any other dangerous devices which may be used to commit an act of unlawful interference, the carriage or bearing of which is not authorised, from being introduced, by any means whatsoever, on board an aircraft engaged in international civil aviation. Note: In applying this standard, special attention must be paid to the threat posed by explosive devices concealed in, or using electric, electronic or battery operated items carried as hand baggage and/or in checked baggage.

25.9 Law Enforcement Officers. Contracting States should ensure that the carriage of weapons on board aircraft, by law enforcement officers and other authorised persons, acting in the performance of their duties, requires special authorisation in accordance with the laws of the States involved. The pilot-in-command is notified as to the number of armed persons and their seat location. Additionally, all en route states as well as the departure and destination states and the aerodrome authorities, must approve the transit of armed security personnel.

25.10 Passengers and Their Baggage. Each contracting state is required to ensure that adequate measures exist to control the transfer and transit of passengers and their cabin baggage to prevent unauthorised article being taken on board aircraft engaged in international civil aviation. States are also to ensure that there is no possibility of mixing or contact between passengers subjected to security control and other persons not subjected to security control, after the security screening at airports has been applied. If mixing does occur, the passengers and their baggage will be re-screened before boarding an aeroplane.

25.11 Deportees and Persons in Custody. States are required to establish procedures to ensure that the operator and the PIC are informed when deportees and persons in custody are travelling so that the appropriate security measures can be enforced. Operators are to ensure that procedures are detailed for the carriage of deportees and persons in custody. JAR OPS increases this responsibility to include other 'potentially disruptive' passengers, these include person who have been declared as inadmissible.

25.12 Checked Baggage and Other Goods. States are required to establish measures to ensure that operators do not transport the baggage of passengers who are not on board the aeroplane unless the baggage is stowed in separate compartments from the passengers, and it has been the subject of other security control measures.

25.13 Access. States are required to establish procedures and identification systems to prevent unauthorised access by persons or vehicles to the airside of an aerodrome serving international civil aviation, and other areas of importance to the security of the aerodrome (ie ATC etc.).

MANAGEMENT OF RESPONSE TO ACTS OF UNLAWFUL INTERFERENCE

25.14 Safety of Passengers and Crew. Each Contracting State shall take adequate measures for the safety of passengers and crew of an aircraft which is subjected to an act of unlawful interference until their journey can be continued.

25.15 Air Traffic Control. Each Contracting State responsible for providing air traffic services for an aircraft which is the subject of an act of unlawful interference shall collect all pertinent information on the flight of that aircraft and transmit that information to all other State responsible for the Air Traffic Services units concerned, including those at the airport of known or presumed destination, so that timely and appropriate safeguarding action may be taken en route and at the aircraft's known, likely or possible destination. Each Contracting State should ensure that information received as a consequence of action taken is distributed locally to the Air Traffic Services units concerned, the appropriate airport administrations, the operator and others concerned as soon as practicable.

25.16 Provision of Assistance. Each Contracting State shall provide such assistance to an aircraft subjected to an act of unlawful seizure, including the provision of navigation aids, air traffic services and permission to land as may be necessitated by the circumstances.

25.17 Detention on the Ground. Each Contracting State shall take measures, as it may find practicable, to ensure that an aircraft subjected to an act of unlawful seizure which has landed in its territory is detained on the ground unless its departure is necessitated by the overriding duty to protect human life, recognizing the importance of consultations, wherever practicable, between the State where that aircraft has landed and the State of the operator of the aircraft, and notification by the State where the aircraft has landed to the States of assumed or stated destination. The state is required to make provision for the comfort and safety of the crew and passengers until they can continue their journey.

25.18 Operator Security Programme. Each contracting state is required to ensure that air transport operators have established, implemented and maintain a written security programme that meets the requirements of the national aviation security programme for that State. Where code sharing is implemented the operator is to ensure/confirm that its partner airline complies with the operator security programme.

FURTHER SECURITY INFORMATION

25.19 Other Annexes and Documents. The content of other ICAO Annexes and Documents relates directly to security. The student is required to revise the following.

25.20 Extracts from Annex 2 - Rules of the Air

- **Unlawful interference.** An aircraft which is being subjected to unlawful interference shall endeavour to notify the appropriate ATS unit of this fact, any significant circumstances associated therewith and any deviation from the current flight plan necessitated by the circumstances, in order to enable the ATS unit to give priority to the aircraft and to minimise conflict with other aircraft. The following procedures are intended as guidance for use by aircraft when unlawful interference occurs and the aircraft is unable to notify an ATS unit of this fact.
- **Action by PIC.** Unless considerations aboard the aircraft dictate otherwise, the pilot-in-command should attempt to continue flying on the assigned track and at the assigned track and at the assigned cruising level at least until able to notify an ATS unit or within radar coverage.
- **Departure from assigned track.** When an aircraft subjected to an act of unlawful interference must depart from its assigned track or its assigned cruising level without being able to make radiotelephony contact with ATS, the pilot-in-command should, wherever possible:
 - Attempt to broadcast warnings on the VHF emergency frequency and other appropriate frequencies, unless considerations aboard the aircraft dictate otherwise. Other equipment such as on-board transponders, data links, etc should also be used when it is advantageous to do so and circumstances permit; and
 - Proceed in accordance with applicable special procedures for in-flight contingencies, where such procedures have been established and promulgated
 - If not applicable regional procedures have been established, proceed at a level which differs from the cruising levels normally used for IFR flight in the area by 300m (1,000 ft) if above FL290 or by 150m (500 ft) if below FL290.

25.21 Extracts from Annex 6 - Operation of Aircraft (Part I - International Commercial Air Transport).

- **Security of the flight crew compartment.** In all aeroplanes which are equipped with a flight crew compartment door, this door shall be capable of being locked. It shall be lockable from within the compartment only.
- **Aeroplane search procedure checklist.** An operator shall ensure that there is on board a checklist of the procedures to be followed in searching for a bomb in case of suspected sabotage. The checklist shall be supported by guidance on the course of action to be taken should a bomb or suspicious object be found and information on the least risk bomb location specific to the aeroplane.

- **Training programmes.** An operator shall establish and maintain a training programme which enables crew members to act in the most appropriate manner to minimize the consequences of acts of unlawful interference. An operator shall also establish and maintain a training programme to acquaint appropriate employees with preventive measures and techniques in relation to passengers, baggage, cargo, mail, equipment, stores and supplies, intended for carriage on an aeroplane so that they contribute to the prevention of acts of sabotage or other forms of unlawful interference.
- **Reporting acts of unlawful interference.** Following an act of unlawful interference the pilot-in-command shall submit, without delay, a report of such an act to the designated local authority.
- **Least Risk-bomb Location.** Specialised means of attenuating and directing the blast should be provided for use at the least-risk bomb location.
- **Carriage of Weapons.** Where an operator accepts the carriage of weapons removed from passengers, the aeroplane should have provision for stowing such weapons in a place so that they are inaccessible to any person during flight time.

25.22 Extracts from Annex 9 - Facilitation

- **Transit and Transfer of Passengers and Crew.** Contracting States should ensure that physical facilities at airports are provided, where the volume and nature of the traffic so require, whereby crew and passengers in direct transit on the same aircraft, or transferring to other flights, may remain temporarily without being subject to inspection formalities, except for aviation security measures, or in special circumstances. Note: This provision is not intended to prevent the application of appropriate narcotics control measures.
- **Inadmissible Persons.** Where a person is returned to the Operator for repatriation to the State of Departure or any other State to which the person is admissible, if that person is inadmissible to the State of Destination, nothing will prevent the operator from seeking compensation from the passenger in the State of Departure.
- **Deportees.** Contracting States removing deportees from their territory are to assume all obligations and costs associated with the removal.

25.23 Extracts from the procedures for air navigation services - Rules of the Air and Air Traffic Services (DOC 4444)

- **Emergency Procedures.** The various circumstances surrounding each emergency situation preclude the establishment of exact detailed procedures to be followed. The procedures outlined herein are intended as a general guide to air traffic services personnel. Air traffic control units shall maintain full and complete co-ordination, and personnel shall use their best judgement in handling emergency situations. To indicate that it is in a state of emergency, an aircraft equipped with an SSR transponder might operate the equipment as follows:
 - Mode A, Code 7700;
 - or
 - Mode A, Code 7500, to indicate specifically that it is being subjected to unlawful interference.

- **Priority.** An aircraft known or believed to be in a state of emergency, including being subjected to unlawful interference shall be given priority over other aircraft.
 - **Unlawful interference.** Air traffic services personnel shall be prepared to recognize any indication of the occurrence of unlawful interference with an aircraft.
 - **Verification of special SSR codes.** Whenever unlawful interference with an aircraft is suspected, and where automatic distinct display of SSR Mode A Code 7500 and Code 7700 is not provided, the radar controller shall attempt to verify his suspicion by setting the SSR decoder to Mode A Code 7500 and thereafter to Code 7700. An aircraft equipped with an SSR transponder is expected to operate the transponder on Mode A Code 7500 to indicate specifically that it is the subject of unlawful interference. The aircraft may operate the transponder on Mode A Code 7700, to indicate that it is threatened by grave and imminent danger, and requires immediate assistance.
 - **ATC Response.** Whenever unlawful interference with an aircraft is known or suspected, ATS units shall promptly attend to requests by or to anticipated needs of the aircraft, including requests for relevant information relating to air navigation facilities, procedures and services along the route of flight and at any aerodrome of intended landing, and shall take such action as is necessary to expedite the conduct of all phases of the flight. ATS units shall also:
 - Transmit, and continue to transmit, information pertinent to the safe conduct of the flight, without expecting a reply from the aircraft.
 - Monitor and plot the progress of the flight with the means available, and co-ordinate transfer of control with adjacent ATS units without requiring transmissions or other responses from the aircraft, unless communication with the aircraft remains normal.
 - Inform and continue to keep informed, appropriate ATS units, including those in adjacent flight information regions, which may be concerned with the progress of the flight.
- Note:** *In applying this provision, account must be taken of all the factors which may affect the progress of the flight, including fuel endurance and the possibility of sudden changes in route and destination. The objective is to provide, as far in advance as is practicable in the circumstances, each ATS unit with appropriate information as to the expected or possible penetration of the aircraft into its area of responsibility.*
- Notify:
 - The operator or his designated representative.
 - The appropriate RCC in accordance with appropriate alerting procedures.
 - The designated security authority. It is assumed that the designated security authority and/or the operator will in turn notify other parties concerned in accordance with pre-established procedures.

- Relay appropriate messages, relating to the circumstances associated with the unlawful interference, between the aircraft and designated authorities.

25.24 Extracts from Annex 14 - Aerodromes

- **Isolated Aircraft Parking Position.** An isolated aircraft parking position is to be designated for the parking of aircraft subject to unlawful interference. The position shall be never less than 100m from other parking positions. It is not to be over underground utilities such as gas and aviation fuel and where feasible electrical or communications cables.

QUESTIONS

1. When taking firearms on board an aeroplane, carried by an authorised person, who needs to be informed?
 - a. The commander.
 - b. The commander and the authority of the state of destination.
 - c. The authority of the state of destination.
 - d. The operator.
2. In ICAO Annex 17 (Security), what does Security mean?
 - a. To safeguard international civil aviation operations against Unlawful Interference.
 - b. To safeguard international civil aviation operations.
 - c. To safeguard international civil aviation operations against hi-jacking.
 - d. To safeguard international civil aviation operations against terrorism.
3. ICAO Annex 17 states that each State is responsible for establishing security at:
 - a. all aerial locations within the FIR.
 - b. at each aerodrome serving international civil aviation.
 - c. all international airports.
 - d. all international and commercial airports.
4. Contracting States must design a security programme, with regard to Unlawful Interference, to safeguard:
 - a. passengers, cargo and crews for international flights.
 - b. passengers, crews, ground personnel and the general public.
 - c. crews only for international flights.
 - d. passengers, cargo and crews for international flights and, at their discretion, all of these for domestic flights.
5. If armed personnel are to be carried to ensure the safety of an aircraft, then:
 - a. the PIC must be informed.
 - b. the state of departure must notify the state of arrival.
 - c. the state of departure must notify the airport of arrival.
 - d. all of the above.
6. According to Annex 17, security is defined as “a combination of measures and human resources intended to safeguard:
 - a. civil aviation operations against acts of unlawful interference”.
 - b. international civil aviation operations against acts of unlawful interference”.
 - c. international aviation operations against acts of unlawful interference”.
 - d. aviation operations against acts of unlawful interference”.
7. Operators are to ensure that procedures are detailed for the carriage of:
 - a. deportees and people under lawful custody.
 - b. deportees, people under lawful custody and inadmissibles.
 - c. only people under lawful custody when physically restrained.
 - d. only deportees and inadmissibles.

8. Airlines are to have procedures in place when carrying potentially disruptive passengers which include:
- inadmissibles, deportees, persons in custody.
 - persons in custody.
 - inadmissibles, deportees.
 - deportees, persons in custody.
9. An aircraft subjected to Unlawful Interference cannot be denied:
- permission to land and fuel.
 - Air Traffic Services, permission to land and the use of navigational aids.
 - food and water for the occupants of the aircraft.
 - Air Traffic Services and fuel.
10. To whom does the National Security organisation of a state have to make available a written version of its national security programme for civil aviation?
- ICAO and ECAC.
 - ICAO.
 - ECAC.
 - Other States.
11. An isolated parking area is to be provided for an aircraft subjected to unlawful interference which is never less than metres from other parking positions:
- 1000.
 - 2500.
 - 3000.
 - 100.
12. A national civil aviation security programme must be established by:
- ICAO and other organisations including the Contracting States concerned.
 - ICAO.
 - all Contracting States.
 - ECAC.
13. Member States should ensure that specific security measures are conducted in the air transport of potentially disruptive passengers. These are seen as:
- none of the answers are correct.
 - deportees, inadmissible passengers and persons in custody.
 - deportees and inadmissible passengers only.
 - deportees and persons in custody.
14. The State shall take adequate measures for the safety of passengers and crew of an aircraft subjected to an act of unlawful interference until:
- the end of the subsequent investigation.
 - as such time as requested by the passengers and crew.
 - their journey can be continued.
 - they are returned to their country of origin.

15. A person found to be inadmissible shall be given to the custody of the operator who shall be responsible for:
 - a. transportation to where the person commenced his/her journey or to any place where the person is admissible at the expense of the operator without redress.
 - b. transportation to where the person commenced his/her journey or to any place where the person is admissible at the expense of the operator. However nothing precludes the operator from recovering from such a person any transportation costs arising from his/her inadmissibility.
 - c. returning such a person to their country of origin.
 - d. returning such a person to their normal residence.

ANSWERS

Question	Answer	Reference
1.	B	25.9
2.	A	Definitions
3.	B	25.2
4.	D	25.5
5.	D	25.9
6.	A	25.5
7.	A	25.11
8.	A	25.11
9.	B	25.16
10.	D	25.5
11.	D	25.24
12.	C	25.3
13.	B	25.11
14.	C	25.17
15.	B	25.22

CHAPTER TWENTY SIX

AIRCRAFT ACCIDENT AND INCIDENT INVESTIGATION

Contents

INTRODUCTION	457
OBJECTIVE OF INVESTIGATION	458
INVESTIGATIONS.	459
SERIOUS INCIDENTS.	459
EU CONSIDERATIONS.	461
QUESTIONS	462
ANSWERS	464

INTRODUCTION

26.1 Annex 13. The ICAO SARPs for the investigation of aircraft accidents and incidents are contained in Annex 13.

26.2 Applicability. Unless otherwise stated, the specifications for investigations apply to activities following accidents and incidents wherever they occurred. In Annex 13 the specifications concerning the State of the Operator apply only when the aircraft is leased, chartered or interchanged and when that State is not the State of Registry and if it discharges, in respect of the Annex, in part or in whole, the functions and obligations of the State of Registry.

26.3 Accident. An accident is defined as an occurrence associated with the operation of an aircraft which takes place between the time any person boards the aircraft with the intention of flight until such time as all such persons have disembarked, in which:

- A person is fatally or seriously injured as a result of:
 - Being in the aircraft, or
 - Direct contact with any part of the aircraft, including parts which have become detached from the aircraft, or
 - Direct exposure to jet blast.

Except when the injuries are from natural causes, self inflicted or inflicted by other persons, or when the injuries are to a stowaway hiding outside the areas normally available to the passengers and crew, or

- The aircraft sustains damage or structural failure which:
 - Adversely affects the structural strength, performance or flight characteristics of the aircraft, and
 - Would normally require major repair or replacement of the affected component.

Except for engine failure or damage, when the damage is limited to the engine, its cowlings or accessories; or for damage limited to propellers, wing tips, antennas, tyres, brakes, fairings, small dents or puncture holes in the aircraft skin, or

- The aircraft is missing or completely inaccessible.

Note: The difference between an accident and a serious incident lies only in the result.

Definitions. The following additional definitions are required knowledge.

Item	Definition
Incident	An occurrence, other than an accident, associated with the operation of an aircraft which affects or could affect the safety of operation.
Investigation	A process conducted for the purpose of accident prevention which includes the gathering and analysis of information, the drawing of conclusions, including the determination of causes and, when appropriate, the making of safety recommendations.
Serious incident	An incident involving circumstances indicating that an accident nearly occurred. (Examples given at para 26.3).
Serious injury	<p>An injury which is sustained by a person in an accident and which:</p> <ul style="list-style-type: none"> ➤ Requires hospitalisation for more than 48 hours commencing within seven days from the date the injury was received, and ➤ Results in a fracture of any bone (except simple fractures of fingers, toes, or nose), or ➤ Involves lacerations which cause severe haemorrhage, nerve, muscle or tendon damage, or ➤ Involves injury to an internal organ, or ➤ Involves second or third degree burns, or any burns affecting more than 5% of the body surface, or ➤ Involves verified exposure to infectious substances or injurious radiation.
State of design	The State having jurisdiction over the organisation responsible for the type design.
State of manufacture	The State having jurisdiction over the organisation responsible for the final assembly of the aircraft.
State of occurrence	The State in the territory of which an accident or incident occurs.

OBJECTIVE OF INVESTIGATION

26.4 Objective. The objective of the investigation of an accident or incident shall be the prevention of accidents and incidents. It is not the purpose of this activity to apportion blame or liability.

INVESTIGATIONS

26.5 Responsibility for Instigating an Investigation. Where an accident or serious incident occurs in the territory of a contracting state (other than the State of Registry or the State of the Operator), the State of occurrence is to instigate the investigation. If the accident or incident occurred in a non contracting state, the state of registry should endeavour to instigate an investigation. If the accident or incident occurred outside the territory of any state or the location of the occurrence cannot be determined, the State of Registry is to instigate the investigation. If the State of Occurrence declines to investigate the incident, the State of Registry (or the State of the Operator) may investigate.

26.6 Participation. The State of Registry, the State of the Operator, the State of Design and the State of Manufacture, are entitled to be represented at any investigation. Any state, which when requested provides information, facilities, or experts to the state conducting the investigation, is entitled to be represented at the investigation. Where the citizens of a state have suffered fatalities or serious injuries, that state, if a request has been made, will be permitted to appoint an expert who should be entitled to:

- Visit the scene of the accident
- Have access to the relevant factual information
- Participate in the identification of the victims
- Assist in questioning survivors who are citizens of that state
- Receive a copy of the final report

26.7 Final Report. The final report of an investigation of an accident is to be sent with the minimum delay, by the State conducting the investigation to:

- The state that instigated the investigation
- The state of Registry
- The state of the Operator
- The state of Design
- The state of Manufacture
- Any state who's citizens have suffer fatalities or injuries, and
- Any state which provided relevant information, significant facilities or experts

26.8 ICAO. If the investigation concerned an aircraft with max mass over 2250kg the final report is also to be sent to ICAO.

SERIOUS INCIDENTS

26.9 Examples. The incidents listed are typical examples of incidents that are likely to be serious incidents. The list is not exhaustive and only serves as guidance to the definition of serious incident.

- Near collisions requiring an avoidance manoeuvre to avoid a collision or an unsafe situation or when an avoidance action would have been appropriate.
- Controlled flight into terrain only marginally avoided.
- Aborted take-offs on a closed or engaged runway.
- Take-offs from a closed or engaged runway with marginal separation from obstacle(s).
- Landings or attempted landings on a closed or engaged runway.
- Gross failures to achieve predicted performance during take-off or initial climb.
- Fires and smoke in the passenger compartment, in cargo compartments or engine fires, even though such fires were extinguished by the use of extinguishing agents.
- Events requiring the emergency use of oxygen by the flight crew.
- Aircraft structural failures or engine disintegrations not classified as an accident.
- Multiple malfunctions of one or more aircraft systems seriously affecting the operation of the aircraft.
- Flight crew incapacitation in flight.
- Fuel quantity requiring the declaration of an emergency by the pilot.
- Take-off or landing incidents including undershooting, overrunning or running off the sides of runways.
- Systems failures, weather phenomena, operations outside the approved flight envelope or other occurrences which could have caused difficulties controlling the aircraft.
- Failures of more than one system in a redundancy system mandatory for flight guidance and navigation.

EU CONSIDERATIONS

26.10 Directive 94/56. The EU Council Directive 94/56 specifies the requirements for Accident Investigation relating to accidents and serious incidents concerning aircraft registered in member states. The directive is similar in content to Annex 13.

26.11 Scope. The directive states that the EU investigation procedure will apply to all accidents and serious incidents that occur in the territory of community states, also to accidents and serious incidents occurring outside the community territory where such occurrences are not investigated by another state.

QUESTIONS

1. An aircraft wheel gets stuck in the mud whilst taxiing to the runway for take-off and sustains damage. Is this:
 - a. an incident.
 - b. an accident.
 - c. a serious incident.
 - d. a normal operating hazard.

2. Who is responsible for the investigation of an accident?
 - a. State of Occurrence.
 - b. State or Registry.
 - c. ICAO.
 - d. Combination of A and B.

3. The purpose of Accident Investigations is the prevention of future accidents and:
 - a. apportion blame.
 - b. to improve manufacturing design.
 - c. to help judicial proceedings.
 - d. nothing more.

4. Just before arrival at the apron, the aircraft unintentionally taxis onto the grass causing the wheel to ride into a pothole. The aircraft has sustained serious damage and consequently the crew is forced to delay the departure:
 - a. considering that there is no physical injury and that the flight has ended, the action that has to be taken is merely confined to notification of the insurance company, the mechanic, the operator and persons who are in charge of runways and taxiways.
 - b. this is an accident and the crew should follow the appropriate procedures.
 - c. this is an incident and the captain has to report this to the aerodrome authority within 48 hours.
 - d. this is an irregularity in the exploitation. This crew should inform the operator about the delay caused by necessary repairs.

5. Who is entitled to be represented at any investigation?
 - a. The State of Registry.
 - b. The State of Design.
 - c. The State of Manufacture.
 - d. All the above.

ANSWERS

Question	Answer	Reference
1.	B	26.3
2.	D	26.5
3.	D	26.4
4.	B	26.3
5.	D	26.6

CHAPTER TWENTY SEVEN

REVISION QUESTIONS

Contents

REVISION QUESTIONS.467
ANSWERS TO REVISION QUESTIONS492
JAA SPECIMEN EXAMINATION493
ANSWERS TO SPECIMEN JAA EXAMINATION506

REVISION QUESTIONS

1. ICAO Annex 17 lays down the rules to establish security measures for passengers with regard to:
 - a. cabin baggage, checked baggage, cargo and other goods, access control and airport design.
 - b. cabin baggage and checked baggage.
 - c. passenger baggage.
 - d. cabin baggage, checked baggage, cargo and other goods and access control.
2. Except in special cases, the establishment of change-over points shall be limited to route segments of:
 - a. 100 nms or more.
 - b. 75 nms or more.
 - c. 60 nms or more.
 - d. 50 nms or more.
3. Except when cleared by an ATC unit, a VFR flight cannot enter or leave a Control Zone when the cloud base is lower than:
 - a. 1,000 ft and less than 8 kms visibility.
 - b. 2,000 ft and less than 5 kms visibility.
 - c. 1,500 ft or less than 5 kms visibility.
 - d. 1,000 ft and less than 5 kms visibility.
4. When requesting to engage the parking brake, a marshaller will give the following signal:
 - a. arms repeatedly crossed over the head.
 - b. arms placed down and crossed in front of the body moving horizontally.
 - c. raise arm and hand with fingers extended horizontally in front of the body. Then clench fist.
 - d. arms placed horizontally sideways with palms towards the ground beckoning downwards.
5. When doing a procedure turn ($45^\circ/180^\circ$) going outbound turned 45° off track, the time taken from the beginning of the turn for Cat A and Cat B aircraft is:
 - a. 1 minute 30 seconds.
 - b. 1 minute.
 - c. 1 minute 15 seconds.
 - d. 2 minutes.
6. Concerning the three entries to the hold, the entry has to be flown on:
 - a. heading.
 - b. track.
 - c. course.
 - d. bearing.

7. When given instructions to set a mode/code, a pilot shall:
- only use the word "wilco".
 - only read back the code.
 - only use the word "roger".
 - read back mode and code.
8. In an instrument approach procedure, the segment, where the aircraft is lined up with the runway centre line and when the descent is commenced is called:
- intermediate approach segment.
 - initial approach segment.
 - arrival segment.
 - final approach segment.
9. What does DER mean?
- distance end of route.
 - departure end of runway.
 - distance end of runway.
 - departure end of route.
10. What action should be taken when, during an IFR flight in VMC, you suffer a radio failure?
- Return to the aerodrome from which you departed.
 - Continue flying in VMC and land as soon as possible.
 - Maintain your assigned altitude and land at the nearest aerodrome at which there are VMC conditions.
 - Continue flying at your assigned altitude and start your approach at your ETA.
11. An ATS airspace, in which IFR and VFR flights are permitted and all flights receive air traffic control service; IFR flights are separated from other IFR flights and receive traffic information concerning VFR flights and VFR flights receive traffic information concerning all other flights, is classified as:
- Airspace E.
 - Airspace B.
 - Airspace A.
 - Airspace D.
12. What is the speed limit (IAS) in airspace E?
- 250 kts for IFR and VFR, below FL 100.
 - 250 kts for IFR only, below FL 195.
 - 250 kts for IFR and VFR, at all altitudes.
 - 250 kts for IFR only, below FL 100.
13. Who has the final authority as to the disposition of the aircraft?
- The State.
 - The Operator.
 - The Commander.
 - The owner.

14. Who is responsible for the safety of an ATC clearance concerning terrain clearance?
- The ATS reporting point when accepting the flight plan.
 - The Captain.
 - The Operator of the aircraft.
 - ATC.
15. In Mode 2 Parallel Runway operations, a minimum radar separation can be provided of:
- 3 nms between aircraft on the same localiser course.
 - 2 nms between aircraft on the same localiser course.
 - 3 nms between aircraft on adjacent localiser courses.
 - 5 nms between aircraft on the same localiser course.
16. For a controlled flight before departure, a flight plan must be filed at least:
- 50 minutes before off-block time.
 - 60 minutes before departure.
 - 10 minutes before departure.
 - 30 minutes before off-block time.
17. An aircraft, on a radar approach, should be told to consider making a missed approach when the aircraft is not visible on the radar screen for a significant period of time and when it is within:
- the last 2 nms of the approach.
 - the last 5 nms of the approach.
 - the last 4 nms of the approach.
 - the last 3 nms of the approach.
18. Clocks and other timing equipment used by air traffic services must be checked in order to be able to give the time within plus or minus:
- 15 seconds of UTC.
 - 10 seconds of UTC.
 - 30 seconds of UTC.
 - 1 minute of UTC.
19. Track separation between aircraft, using the same fix (ie DR !), has to be applied when aircraft:
- have to fly 45° separated at a distance of 15 miles or more from the fix.
 - have to fly 45° separated at a distance of 15 nms or more from the fix.
 - have to fly 30° separated at a distance of 15 nms or more from the fix.
 - have to fly 30° separated at a distance of 15 miles or more from the fix.
20. An aircraft making an approach must be told to make a missed approach, when no landing clearance has been received from the non-radar traffic controller, when the aircraft is at a distance of:
- 5 nms from the touchdown.
 - 1.5 nms from the touchdown.
 - 4 nms from the touchdown.
 - 2 nms from the touchdown.

21. Temporary changes of long duration in specifications for AIP supplements and information of short duration, which contains extensive text and / or graphical representation, has to be published as AIP supplements. Long duration is considered to be:
- 3 months or longer.
 - 2 months or longer.
 - 1 year or longer.
 - 6 months or longer.
22. How many red lights have to be seen by the pilot, who's aircraft on final approach follows a normal PAPI defined glide-path?
- 2
 - none
 - 3
 - 1
23. A Clearway is a squared area that is established to:
- protect aircraft during take-off and landing.
 - to enable the aircraft to stop in the case of an aborted take-off.
 - to enable the aircraft to make a part of the initial climb to a specified altitude.
 - to decrease the risk of damage to aircraft which run off the end of the runway.
24. It says in the Annex of the ICAO convention that the sizes of airfields are specified by codes for different runways. What is the minimum width of a runway with runway code 4?
- 40m.
 - 45m.
 - 50m.
 - 35m.
25. When someone's admittance to a country is refused and he/she is brought back to the operator for transportation away from the territory of the state:
- the operator won't take any transportation costs from the passenger which arise from his/her inadmissibility.
 - the operator is not responsible for that person, to whom the admittance to the host country is refused.
 - the operator and state of the operator are both responsible for the refused person.
 - the operator will not be prevented from taking any transport costs from a person which arises out of his/her inadmissibility.
26. An aircraft which is not concerned with regular international flights and which makes a flight to or via a dedicated aerodrome of a member State and is temporarily free of taxes is admitted, will stay within that State without paying customs:
- during a period which is determined by the State.
 - during a period of 24 hours.
 - during a period of 12 hours.
 - during a period of 48 hours.

27. An aircraft flies over mountainous terrain at which a search and rescue operation is conducted to find survivors of a plane crash. The pilot sees a ground sign in the form of a "X". This indicates:
- we have found all personnel.
 - engineering assistance required.
 - landing impossible.
 - require medical assistance.
28. A controlled flight is required to inform the concerned ATC unit when the average TAS at cruising level deviates or is expected to deviate compared to that given TAS in the Flight Plan by at least plus or minus:
- 10%.
 - 3%.
 - 5%.
 - 2%.
29. Concerning aircraft registration markings, no combinations can be used if they can be mistaken for:
- codes which are used for identification of ICAO documents.
 - letter combinations beginning with Q.
 - 3 letter combinations which are used by international code of signals.
 - 5 letter combinations which are used by international code of signals.
30. What is the rule concerning level or height the aircraft should maintain when flying IFR outside controlled airspace unless otherwise directed?
- 2,000 ft above the highest obstacle within 8 kms of the heading.
 - 1,000 ft above the highest obstacle within 8 kms of the estimated position of the aircraft.
 - 1,000 ft above the highest obstacle within 8 nms of the planned track.
 - 2,000 ft above the highest obstacle within 8 nms of the planned track.
31. An aircraft is expected to overtake another aircraft is closing from behind in a sector of:
- 50° both sides of the longitudinal axis.
 - 60° both sides of the longitudinal axis.
 - 80° both sides of the longitudinal axis.
 - 70° both sides of the longitudinal axis.
32. Aircraft A flies in VMC with an ATC clearance within a control area. Aircraft B without ATC clearance approaches at roughly the same height on a converging heading. Who has right of way?
- Aircraft A, regardless of the direction from which B approaches.
 - Aircraft B, regardless of the direction from which A approaches.
 - Aircraft A, if B is to the right of him.
 - Aircraft B, if A is to the left of him.

33. The person having overall responsibility of an aircraft during flight is the:
- pilot in command.
 - operator.
 - ATC Controller if the aircraft is in controlled airspace.
 - owner of the aircraft.
34. Pilots are not allowed to use the indent function on their SSR, unless:
- they operate outside controlled airspace.
 - if asked by ATC.
 - with are within controlled airspace.
 - they operate a transponder with mode C.
35. Transition Level:
- will be given by NOTAM.
 - is published on every approach and landing chart for every airfield.
 - will be calculated by the pilot in command.
 - will be calculated by the ATC service of an ATS unit.
36. It is permitted in a particular sector, if there is a conspicuous obstacle in the visual maneuvering area outside the final and missed approach areas, to disregard that obstacle. When using this option, the published procedure shall be:
- circling is only permitted in VMC.
 - recommended not to execute a circling approach in the entire sector in which the obstacle is situated.
 - prohibit a circling approach for the concerned runway.
 - forbid a circling approach in the entire sector in which the obstacle is located.
37. If the track on an instrument departure is published the pilot is expected to:
- correct for the known wind so as to stay within controlled airspace.
 - ask ATC for another heading to steer correcting for wind.
 - ignore the wind and proceed with a heading equal to the track.
 - ask ATC for permission to correct heading for wind.
38. Close to an aerodrome that will be used for landing by aircraft, the vertical position shall be expressed as:
- altitude above sea level on or above transition altitude.
 - flight level on or under the transition altitude.
 - flight level on or under the transition level.
 - altitude above sea level at or below transition altitude.
39. A manoeuvre where a turn is made from a "designated track" followed by a turn in the opposite direction to enable the aircraft to fly the prescribed track is called:
- base turn.
 - reverse track.
 - race track.
 - procedure turn.

40. The transition of altitude to flight level and visa versa is made:
- on the transition level in the climb and transition altitude in the descent.
 - at the transition altitude in the climb and transition level in the descent.
 - at the transition level only.
 - at the transition altitude only.
41. Lights on an airfield or in the vicinity can be extinguished if they can be re-lit:
- at least 5 minutes before the ETA of the aircraft.
 - at least 15 minutes before the ETA of the aircraft.
 - at least 30 minutes before the ETA of the aircraft.
 - at least 60 minutes before the ETA of the aircraft.
42. Air Traffic Service unit consists of:
- Air Traffic Control Units and Flight Information Centers.
 - Flight Information Centers and Air Services Reporting offices.
 - Air Traffic Control Units, Flight Information Centers and Air Traffic Services Reporting offices.
 - Air Services Reporting offices and Air Traffic Control Units.
43. An aircraft is maintaining FL 150 in Class C Airspace. Another aircraft below at FL 140 receives a clearance to descend to FL 70. There is severe turbulence in the area. When at earliest can a clearance be expected to descend to FL 140 or lower?
- When the other aircraft has reported to be descending through FL 130.
 - When the other aircraft has reported to have left FL 120.
 - When the other aircraft has reported to have left FL 140.
 - When the other aircraft has reached FL 70.
44. When the captain cannot comply with an ATC clearance:
- the Captain must accept the ATC clearance, because it is based on a filed flight plan.
 - he/she may request an amended clearance and, if executable, he/she will accept that clearance.
 - he/she may ask a new clearance and the appropriate ATC must grant him/her that clearance.
 - he/she may suggest a new clearance to ATC.
45. The transition from IFR to VFR is done:
- on the Captain's initiative.
 - whenever an aircraft in VMC leaves controlled airspace.
 - if told by ATC.
 - at the clearance limit, disregarding the weather situation.
46. According to international agreements the wind direction must be given in degrees magnetic converted with local magnetic variation from the true wind direction:
- before landing and taxi for take-off.
 - in anticipation of the upper wind for areas North of 60° N and South of 60° S.
 - when an aircraft is requested by the meteorological office or on specified points to give a PIREP.
 - when the local variation is greater than 10° East or West.

47. The longitudinal separation minimum based on time between aircraft at the same FL, where there is enough coverage for navigation aids and the preceding aircraft has a higher true airspeed of 20 kts minimum is:
- 3 minutes.
 - 15 minutes.
 - 5 minutes.
 - 10 minutes.
48. When independent parallel approaches are used on parallel runways and headings (vectors) are given to intercept the ILS, the given heading must be such that the aeroplane can establish on the localiser course or the MLS final approach track in level flight over at least:
- 2.5 nms before the ILS glide slope or the specified MLS elevation angle is intercepted.
 - 1.5 nms before the ILS glide slope or the specified MLS elevation angle is intercepted.
 - 3.0 nms before the ILS glide slope or the specified MLS elevation angle is intercepted.
 - 2.0 nms before the ILS glide slope or the specified MLS elevation angle is intercepted.
49. What is the length of the approach lighting system of a Cat II precision landing runway?
- 900m.
 - 600m.
 - 300m.
 - 150m.
50. A PAPI must consist of:
- a row of 4 multiple lights or paired units without transition zone, at equal distance from each other.
 - two rows of 4 multiple lights or paired units without transition zone, at equal distance from each other.
 - a row of 2 multiple lights or paired units without transition zone, at equal distance from each other.
 - two rows of 6 multiple lights or paired units without transition zone, at equal distance from each other.
51. Lights at the end of the runway shall be:
- steady unidirectional lights radiating white light in the direction of the runway.
 - steady white lights with controllable intensity.
 - steady omnidirectional red lights with controllable intensity.
 - steady unidirectional lights radiating red light in the direction of the runway.
52. An aircraft is allowed to descend below the MSA if:
- the pilot follows the published approach procedures.
 - the aircraft receives radar vectors.
 - the pilot has visual contact with the runway and surrounding terrain and is able to maintain visual contact.
 - all of the above.

53. Repetitive flight plans (RPL's) cannot be used for flights other than those executed frequently on the same days of following weeks and:
- for at least 20 occasions or every day over a period of at least 20 consecutive days.
 - for at least 20 consecutive days.
 - for at least 10 occasions or every day over a period of at least 10 consecutive days.
 - for at least 20 occasions.
54. The VMC minima for a VFR flight within ATS airspace class B are:
- 8 km visibility at or above 3050m AMSL and clear of cloud.
 - 5 nms visibility at or above 3050m AMSL, 1500m horizontal and 300m vertical clear of cloud.
 - 8 kms visibility at or above 3050m AMSL, 1500m horizontal and 300m vertical clear of cloud.
 - 5 nms visibility at or above 3050m AMSL and clear of cloud.
55. The minimum response time for the aerodrome rescue and fire fighting services to the end of each runway as well as to any other part of the movement area is:
- 3 minutes and not exceeding 4 minutes.
 - 2 minutes and not exceeding 3 minutes.
 - 2 minutes and not exceeding 4 minutes.
 - 3 minutes and not exceeding 5 minutes.
56. The minimum number of rescue and fire fighting vehicles required for a Cat 8 Aerodrome is:
- 3
 - 4
 - 5
 - None of the above is correct.
57. A fixed obstacle that extends above a take-off climb surface within shall be marked and, the runway is to be used at night, must be lit.
- 3000m
 - 3,000 ft
 - 5000m
 - 2 nms
58. A marshaller crosses his/her hands in front of the face, palms outwards and then moves the arms outwards. What does this signal indicate?
- Clear to move forward.
 - Brakes off.
 - Remove chocks.
 - Clear to close all engines.
59. What is required for an IFR flight in advisory airspace?
- No flight plan required.
 - Flight plan required and PIC must notify of any changes regardless if wanting advisory service or not.
 - Flight plan required but PIC need not notify of any changes.
 - A flight plan is only required if advisory service is required.

60. What is the separation that must be maintained before intercepting the ILS on an independent parallel approach?
- a. 1,000 ft.
 - b. 500 ft.
 - c. 330 ft.
 - d. 660 ft.
61. A Type Rating is applicable to:
- a. an aircraft requiring a Certificate of Airworthiness.
 - b. an aircraft with a Certificate of Airworthiness issued by the State.
 - c. an aircraft that requires multi-pilot operation.
 - d. an aircraft that requires additional skills training.
62. If an aircraft is radar vectored to intercept a ILS localiser, what is that maximum intercept angle?
- a. 45°.
 - b. 30°.
 - c. 15°.
 - d. 20°.
63. What are the objectives of ATC Services?
- a. To prevent collisions between aircraft, to prevent collisions between aircraft on the manoeuvring area and obstructions on that area and to expedite and maintain an orderly flow of air traffic.
 - b. To prevent collisions between controlled aircraft and to expedite and maintain an orderly flow of air traffic.
 - c. To provide separation of aircraft and to expedite and maintain an orderly flow of air traffic.
 - d. To provide separation of controlled aircraft and to expedite and maintain an orderly flow of air traffic.
64. Operationally significant changes to the AIP shall be published in accordance with:
- a. AIC's.
 - b. AIP supplements.
 - c. AIRAC procedures.
 - d. Trigger NOTAMS.
65. A check list of AIP Supplements is published:
- a. annually.
 - b. monthly.
 - c. weekly.
 - d. every six months.

66. A heavy aircraft makes a missed approach on a parallel runway in the opposite direction. A light aircraft has a wake turbulence separation of 2 minutes. This wake turbulence separation will apply when the parallel runways are:
- more than 760m apart.
 - more than 915m apart.
 - less than 915m apart.
 - less than 760m apart.
67. A TODA consists of:
- the take-off run available excluding the clearway.
 - the take-off run available including the clearway.
 - the take-off run available excluding the stopway.
 - the take-off run available only.
68. The continued validity of a C of A of an aircraft is subject to the laws of:
- the State of Registration.
 - the State of Registration and the State of the Operator.
 - the State of the Operator.
 - the State of Registry and the State of Design.
69. ATIS will only broadcast cloud base information when the cloud base is:
- 3,000 ft.
 - 5,000 ft.
 - when Cb's are present.
 - when the cloud base is below MSA.
70. Which International Agreement relates to Penal Law?
- Tokyo.
 - Montreal.
 - Hague.
 - Rome.
71. Voice ATIS:
- cannot be broadcasted on a voice ILS.
 - cannot be broadcasted on voice VOR.
 - is broadcasted only on a discreet VFH frequency.
 - is broadcasted on either a discreet VFH, VOR or an ILS frequency.
- 1 only is correct.
 - 2 only is correct.
 - 4 only is correct.
 - 1, 2 and 3 are correct.

72. Aeroplanes certified to JAR-25 must not operate across areas where S&R would be especially difficult without survival equipment if it flies to a distance corresponding to greater than:
- 30 minutes at cruising speed from an area suitable for making an emergency landing.
 - 60 minutes at cruising speed from an area suitable for making an emergency landing.
 - 90 minutes at cruising speed from an area suitable for making an emergency landing.
 - 120 minutes at cruising speed from an area suitable for making an emergency landing.
73. When a fixed distance marking has to be provided this marking shall commence at:
- 150m from the threshold.
 - 300m from the threshold.
 - 150m from the aiming point.
 - 300m from the aiming point.
74. What is the minimum width of a code 4 runway?
- 18m.
 - 23m.
 - 30m.
 - 45m.
75. What is the width of a code letter D taxiway used by aircraft with an outer gear wheel span of less than 9m ?
- 10.5m.
 - 15m.
 - 18m.
 - 23m.
76. What is the meaning of the symbol LLL search parties?
- We have only found some personnel.
 - We have found all personnel.
 - Operation completed.
 - Nothing found.
77. A RNP1 route designated as A342Z, indicates that the route is at or below FL190 and all turns shall be made within the allowable RNP tolerance of a tangential arc between the straight leg segments with a radius of:
- 10nm for turns between 30° and 90°.
 - 15nm for turns between 30° and 90°.
 - 22.5nm for turns between 30° and 90°.
 - 30nm for turns between 30° and 90°.
78. A RNP1 route designated as A342Y, indicates that the route is at or above FL200 and all turns shall be made within the allowable RNP tolerance of a tangential arc between the straight leg segments with a radius of:
- 10nm for turns between 30° and 90°.
 - 15nm for turns between 30° and 90°.
 - 22.5nm for turns between 30° and 90°.
 - 30nm for turns between 30° and 90°.

79. If no ICAO identifier has been attributed to an aerodrome, what should be entered in Box 16 of the Flight Plan?
- ZZZZ
 - NNNN
 - A/N
 - A/D XXX
80. Which of the following is not a valid SSR mode A squawk?
- A5555
 - A5678
 - A2345
 - A3333
81. A separation minima shall be applied between a light or medium aircraft and a heavy and between a light and a medium aircraft when the heavier aircraft is making a low or missed approach and the lighter aircraft is utilizing an opposite direction runway on a parallel runway separated by:
- less than 915m.
 - more than 760m.
 - less than 760m.
 - more than 915m.
82. A contracting state which continues to require the presentation of a Cargo Manifest shall, apart from the information indicated in the heading of the format of the cargo manifest, not require more than the following items:
- airway bill number, and the number of packages only.
 - total weight and the number of packages only.
 - total weight and the nature of the goods only.
 - airway bill number, the number of packages and the nature of goods.
83. Contracting states shall carry out the handling, forwarding and clearance of airmail and shall comply with the documentary procedures as proscribed by:
- the Acts in force of the Universal Postal Union.
 - the Acts in force of the General Postal Union.
 - the Acts in force of the Warsaw Convention.
 - the Acts in force of the International Postal Union.
84. Unaccompanied baggage carried by air shall be cleared under a procedure applicable to:
- accompanied baggage or under a simplified customs procedure distinct and different from that normally applicable to other cargo.
 - cargo.
 - dangerous goods.
 - mail.

85. An area symmetrical about the extended runway centreline and adjacent to the end of the strip, primarily intended to reduce the risk of damage to an aircraft undershooting or overrunning the runway is defined as a:
- clearway.
 - runway strip extension.
 - runway end safety area.
 - altimeter operating area extension.
86. For an instrument runway, how far from the centre line of the runway is a “runway vacated” sign positioned?
- To a distance of the nearest Pattern ‘A’ holding position.
 - At the end of the ILS/MLS Sensitive Area.
 - It depends on the Aerodrome Category.
 - 85m.
87. What is required if a stop bar is not provided at a runway entrance and runway is to be used with RVR of less than 550m?
- Both a Pattern ‘A’ and ‘B’ holding position.
 - High intensity taxiway centerline lights only.
 - Runway guard lights.
 - Both high intensity taxiway centerline lights and high intensity taxiway edge lights.
88. Independent parallel approaches may be conducted to parallel runways provided that a NTZ of at least:
- 915m is established between extended centre lines.
 - 760m is established between extended centre lines.
 - 1,035m is established between extended centre lines.
 - 610m wide is established between extended centre lines.
89. ATIS broadcasts should contain cloud details, when:
- they are below 2500m.
 - they are below 1500m or MSA, whichever is the greater.
 - they are below 1000m.
 - they are below 1000m or MSA, whichever is the greater.
90. What action should be taken if contact is lost with the runway during a circling approach?
- Descend to Decision Height and if still no contact with the runway, initiate a missed approach.
 - Land on the instrument runway.
 - Initiate a missed approach.
 - Return to the FAF.
91. The height of the marks on lighter than air aircraft other than unmanned free balloons shall be:
- at least 30cm.
 - at least 50cm.
 - at least 60cm.
 - at least 80cm.

92. When an aircraft subjected to unlawful interference has landed in a Contracting State, it shall notify by the most expeditious means of the State of Registry and the State of the Operator of the landing and, in addition, shall similarly transmit all other relevant information to:
- each State whose citizens suffered fatalities or injuries, each State whose citizens were detained as hostages, each State whose citizens were known to be on board and ICAO.
 - ICAO only.
 - each State whose citizens were known to be on board only.
 - ICAO and each State whose citizens were known to be on board only.
93. According to JAR-FCL1, recognised instructor categories are:
- FI(A), TRI(A), CRI(A), IRI(A) only.
 - FI(A) and CRI(A) only.
 - FI(A) and IRI(A) only.
 - FI(A), TRI(A), CRI(A), IRI(A), MCCI(A) and SFI(A) only.
- Note: FI = Flying Instructor, TRI = Type Rating Instructor, CRI = Class Rating Instructor, IRI = Instrument Rating Instructor, MCCI = Multi-crew Co-operation Instructor, SFI = Synthetic Fight Instructor.
94. When a State renders valid a license issued by another Contracting State, as an alternative to issuance of its own license, the validity shall:
- not extend beyond 15 days after the validity of the license.
 - not extend beyond the period of validity of the license.
 - be at the discretion of the Contracting State rendering it valid.
 - be at the discretion of ICAO.
95. Where in the AIP would you find details on instrument holding procedures?
- GEN
 - ENR
 - AD
 - AGA
96. The loading limitations shall include:
- all limiting mass and centres of gravity.
 - all limiting mass, centres of gravity position, mass distributions and floor loading.
 - all limiting mass, centres of gravity position and floor loading.
 - all limiting mass, mass distributions and centres of gravity.
97. The International Civil Aviation Organisation (ICAO) establishes:
- standards and recommended international practices for contracting member states.
 - aeronautical standards adopted by all states.
 - proposals for aeronautical regulations in the form of 18 annexes.
 - standards and recommended practices applied without exception by all states, signatory to the Chicago convention.

98. According to Annex 7, the registration mark shall be letters, numbers or a combination of letters and numbers and shall be that assigned by:
- the State of Registry or Common Mark Registering Authority.
 - the State of Registry only.
 - the International Civil Aviation Organisation.
 - the International Telecommunication Union.
99. According to JAR-FCL, the privileges of the holder of an unrestricted FI(A) rating are to conduct flight instruction for the issue of a CPL(A):
- provided that the FI(A) has completed not less than 15 hours on the relevant type in the preceding 12 months.
 - provided that the FI(A) has completed at least 500 hours of flight time as a pilot of aeroplanes including at least 200 hours of flight instruction.
 - without restriction.
 - provided that the FI(A) has completed 200 hours of flight instruction.
100. According to JAR-FCL, an applicant for a CPL (A) who has satisfactorily followed and completed an integrated flying training course shall have completed as a pilot of aeroplanes having a certificate of airworthiness issued or accepted by a JAA Member State at least:
- 150 hours of flight time.
 - 200 hours of flight time.
 - 150 hours of flight time plus 10 hours of instrument ground time.
 - 200 hours of flight time plus 10 hours of instrument ground time.
101. If radio communication is established during an interception but communications in a common language is not possible, which phrase should be pronounced by the intercepting aircraft to request the intercepted aircraft to descend for landing?
- Let down.
 - Descend.
 - Descend for landing.
 - You land.
102. An aircraft manoeuvring in an airport's circuit receives a series of red flashes from the control tower. This signifies that the aircraft must:
- not land because the airport is not available for landing.
 - give way to another aircraft.
 - return to land and that clearance to land will be communicated in due course.
 - not land for the moment regardless of previous instructions.
103. Which action shall be taken by an aircraft in the traffic pattern of an aerodrome, experiencing radio failure to indicate difficulties which compel it to land without requiring immediate assistance?
- Switching on and off three times the landing lights.
 - The repeated switching on and off of the landing lights.
 - Switching on and off four times the navigation lights.
 - Switching on and off four times the landing lights.

104. The main factor/s that dictate/s in general the design of an instrument departure procedure is/are:
- the terrain surrounding the aerodrome.
 - ATC availability and requirements.
 - availability of navigation aids.
 - airspace restrictions applicable and in force.
105. One of the conditions to descent below the MDA on a circling approach is:
- the landing runway and an alternative landing possibility (runway) are in sight.
 - the required visual references have been established and can be maintained.
 - the Ceiling is 1,500 ft or higher.
 - the horizontal visibility is at least 5 NM and the Ceiling is 1,500 ft or higher.
106. If for any reasons a pilot is unable to conform to the procedures for normal conditions laid down for any particular holding pattern, he should:
- advise ATC as early as possible.
 - execute a non-standard holding pattern in accordance with the performance of his aeroplane.
 - remain within the protected area, but may deviate from the prescribed holding.
 - follow the radio communication failure procedure.
107. The Transition Level:
- shall be the lowest flight level available for use above the transition altitude.
 - shall be the highest available flight level below the transition altitude that has been established.
 - is published for the aerodrome in the Section ENR of the AIP.
 - is calculated and declared for an approach by the Pilot-in command.
108. When the aircraft carries serviceable Mode C transponder, the pilot shall continuously operate this mode:
- only when directed by ATC.
 - unless otherwise directed by ATC.
 - only when the aircraft is flying within controlled airspace.
 - regardless of ATC instructions.
109. The speed limitation for VFR flights inside ATS airspace classified as C, when flying below 3,050 m (10,000 ft) AMSL, is:
- not applicable.
 - 240 KT IAS.
 - 250 KT IAS.
 - 250 KT TAS.

110. The VMC minima for a VFR flight inside an ATS airspace classified as B, is:
- 5 NM visibility below 3050m (10,000 ft) AMSL, clear of clouds.
 - 5 NM visibility when below 3050m (10,000 ft) AMSL, 1500m horizontal and 300m vertical from cloud.
 - 8 km visibility when at or above 3050m (10,000 ft) AMSL and clear of clouds.
 - 8 km visibility when at or above 3050m (10,000 ft) AMSL, and 1500m horizontal and 300 m vertical from clouds.
111. Area Control Centres issue clearances for the purpose of:
- achieving separation between IFR flights.
 - achieving separation between controlled flights.
 - providing advisory service.
 - providing flight Information Service.
112. Flight information service provided to flights shall include the provision of information concerning collision hazards to aircraft operating in airspace classes:
- A to G (inclusive).
 - C to G (inclusive).
 - F and G.
 - A to E (inclusive).
113. The Vertical Separation Minimum (VSM) for flights in accordance with IFR within controlled airspace below FL 290 is:
- 500 ft (150 m).
 - 2,500 ft (750 m).
 - 1,000 ft (300 m).
 - 2,000 ft (600 m).
114. The “Clearance to fly maintaining own separation while in visual meteorological conditions” may be given by the appropriate ATS authority. This has to be requested by the pilot of a controlled flight and has to be agreed by the pilot of the other aircraft. The conditions are:
- Airspace Class C, VMC, hours of daylight.
 - Airspace Class D and E, VMC, hours of daylight.
 - Airspace Class B, C, D and E, VMC.
 - Airspace Class C, D, VMC.
115. For controlled traffic that shall be separated in the vicinity of an airport, separation minima may be reduced:
- if the commander of the involved aircraft so requests.
 - only if the air traffic controller has the involved aircraft in sight.
 - when the commander in the following aircraft has the preceding aircraft in sight and is able to maintain own separation.
 - at the discretion of the air traffic controller.

116. In order to meet the wake turbulence criteria, what minimum separation should be applied when a medium aircraft is taking off behind a heavy aircraft and both are using the same runway?
- 3 minutes.
 - 2 minutes.
 - 1 minute.
 - 4 minutes.
117. Which does ATC Term "Radar contact" signify?
- Your aircraft has been identified on the radar display and radar flight instructions will be provided until radar identification is terminated.
 - Your aircraft has been identified and you will receive separation from all aircraft while in contact with this radar facility.
 - You will be given traffic advisories until advised that the service has been terminated or that radar contact has been lost.
 - ATC is receiving your transponder and will furnish vectors and traffic advisories until you are advised that contact has been lost.
118. When the transponder appears to be unserviceable prior to departure and restore is impossible, than:
- you must indicate the failure in the flight plan, after which the ATC will endeavor to provide for continuation of the flight.
 - departure to the nearest suitable airport where repair can be effected is allowed.
 - you are not allowed to commence the flight.
 - the flight can only continue in the most direct manner.
119. A notice containing information concerning flight safety, air navigation, technical, administration or legislative matters and originated at the AIS of a state is called:
- Aeronautical Information Publication (AIP).
 - Aeronautical Information Circular (AIC).
 - AIRAC.
 - NOTAM.
120. Which part of the AIP contains a list with "Location Indicators"?
- ENR.
 - GEN.
 - LOC.
 - AD.
121. Which "code letter" shall be chosen to identify a taxiway to be used by an aircraft having a wheel base of 15m?
- Code letter "B".
 - Code letter "C".
 - Code letter "E".
 - Code letter "D".

122. In a precision approach category I, lighting system, the single, two and three light sources on the centre line have a length of:
- 250m.
 - 200m.
 - 150m.
 - 300m.
123. When a person is found inadmissible and is returned to the operator for transport away from the territory of the state, the operator:
- shall not be preclude from recovering from such person any transportation costs arising from his (her) inadmissibility.
 - shall not recover from such person any transportation costs arising from his (her) inadmissibility.
 - is not responsible for the person inadmissible for entry in the receiving state.
 - the state of the operator are both responsible for the person inadmissible.
124. Who is responsible for the initiation of an accident investigation?
- The Authority of the State in which the accident took place.
 - The Operators of the same aircraft type.
 - The aircraft manufacturer.
 - The State of design and manufacturer.
125. When it becomes apparent that an aircraft is in difficulty, the decision to initiate the alert phases is the responsibility of the:
- operational air traffic control centres.
 - flight information or control organisations.
 - air traffic co-ordination services.
 - search and rescue co-ordination centres.
126. An aircraft intercepted by a military aircraft shall immediately attempt to establish radio communication with the intercepting aircraft on the following frequencies:
- 121.5 MHz, and if communications cannot be established, on 243.0 MHz.
 - 121.5 MHz, and if communications cannot be established, on 406.0 MHz.
 - 121.5 MHz, and if communications cannot be established, on 282.0 MHz.
 - 243.0 MHz, and if communications cannot be established, on 121.5 MHz.
127. What are the differences between the rules and regulations in the UIR compared with the airspace below?
- The same rules apply.
 - They are agreed by the Air Navigation Meeting.
 - They are identical to the airspace below.
 - They do not have to be identical to the airspace below.

128. Except in special cases, the establishment of change-over points shall be limited to route segments of:
- 100nms or more.
 - 75nms or more.
 - 60nms or more.
 - 50nms or more.
129. The body, which governs licensing of pilot licenses or the equivalent documents, must decide if the experience of the pilot in training done on a simulator is acceptable as part of the total flying time of 1500 hours. **Exemption** from such experience shall be limited to a maximum of:
- 100 hours, of which not more than 15 hours may be done on a flight procedure trainer or a synthetic flight trainer.
 - 75 hours, of which not more than 20 hours may be done on a flight procedure trainer or a synthetic flight trainer.
 - 100 hours, of which not more than 20 hours may be done on a synthetic flight trainer.
 - 100 hours, of which not more than 25 hours may be done on a flight procedure trainer or a basic instrument flight trainer.
130. When given instructions to set a mode/code, a pilot shall:
- only use the word "wilco".
 - only read back the code.
 - only use the word "roger".
 - read back mode and code.
131. Who has the final authority as to the disposition of the aircraft?
- The State.
 - The Operator.
 - The Commander.
 - The owner.
132. Who is responsible for the safety of an ATC clearance concerning terrain clearance?
- The ATS reporting point when accepting the flight plan.
 - The Captain.
 - The Operator of the aircraft.
 - ATC.
133. An aircraft, on a radar approach, should be told to consider making a missed approach when the aircraft is not visible on the radar screen for a significant period of time and when it is within:
- the last 2 nms of the approach.
 - the last 5 nms of the approach.
 - the last 4 nms of the approach.
 - the last 3 nms of the approach.

134. An aircraft which is not concerned with regular international flights and which makes a flight to or via a dedicated aerodrome of a member State and is temporarily free of taxes is admitted, will stay within that State without paying customs:
- during a period which is determined by the State.
 - during a period of 24 hours.
 - during a period of 12 hours.
 - during a period of 48 hours.
135. The person having overall responsibility of an aircraft during flight is the:
- pilot in command.
 - operator.
 - ATC Controller if the aircraft is in controlled airspace.
 - owner of the aircraft.
136. Pilots are not allowed to use the indent function on their SSR, unless:
- they operate outside controlled airspace.
 - if asked by ATC.
 - with are within controlled airspace.
 - they operate a transponder with mode C.
137. Lights on an airfield or in the vicinity can be extinguished if they can be re-lit:
- at least 5 minutes before the ETA of the aircraft.
 - at least 15 minutes before the ETA of the aircraft.
 - at least 30 minutes before the ETA of the aircraft.
 - at least 60 minutes before the ETA of the aircraft.
138. Air Traffic Service unit consists of:
- Air Traffic Control Units and Flight Information Centres.
 - Flight Information Centres and Air Services Reporting offices.
 - Air Traffic Control Units, Flight Information Centres and Traffic Air Services Reporting offices.
 - Air Services Reporting offices and Air Traffic Control Units.
139. According to international agreements the wind direction must be given in degrees magnetic converted with local magnetic variation from the true wind direction:
- before landing and taxi for take-off.
 - in anticipation of the upper wind for areas North of 60° N and South of 60° S.
 - when an aircraft is requested by the meteorological office or on specified points to give a PIREP.
 - when the local variation is greater than 10° East or West.

140. A PAPI must consist of:
- a row of 4 multiple lights or paired units without transition zone, at equal distance from each other.
 - two rows of 4 multiple lights or paired units without transition zone, at equal distance from each other.
 - a row of 2 multiple lights or paired units without transition zone, at equal distance from each other.
 - two rows of 6 multiple lights or paired units without transition zone, at equal distance from each other.
141. Repetitive flight plans (RPL's) cannot be used for flights other than those executed frequently on the same days of following weeks and:
- for at least 20 occasions or every day over a period of at least 20 consecutive days.
 - for at least 20 consecutive days.
 - for at least 10 occasions or every day over a period of at least 10 consecutive days.
 - for at least 20 occasions.
142. Aeroplanes certified to JAR-25 must not operate across areas where S&R would be especially difficult without survival equipment if it flies to a distance corresponding to greater than:
- 30 minutes at cruising speed from an area suitable for making an emergency landing.
 - 60 minutes at cruising speed from an area suitable for making an emergency landing.
 - 90 minutes at cruising speed from an area suitable for making an emergency landing.
 - 120 minutes at cruising speed from an area suitable for making an emergency landing.
143. If no ICAO identifier has been attributed to an aerodrome, what should be entered in Box 16 of the Flight Plan?
- ZZZZ
 - NNNN
 - A/N
 - A/D XXX
144. Which of the following is not a valid SSR mode A squawk?
- A5555
 - A5678
 - A2345
 - A3333
145. Contracting States shall carry out the handling, forwarding and clearance of airmail and shall comply with the documentary procedures as proscribed by:
- the Acts in force of the Universal Postal Union.
 - the Acts in force of the General Postal Union.
 - the Acts in force of the Warsaw Convention.
 - the Acts in force of the International Postal Union.

146. Unaccompanied baggage carried by air shall be cleared under a procedure applicable to:
- accompanied baggage or under a simplified customs procedure distinct and different from that normally applicable to other cargo.
 - cargo.
 - dangerous goods.
 - mail.
147. ATIS broadcasts should contain cloud details, when:
- they are below 2500m.
 - they are below 1500m or MSA, whichever is the greater.
 - they are below 1000m.
 - they are below 1000m or MSA, whichever is the greater.
148. The height of the marks on lighter than air aircraft other than unmanned free balloons shall be:
- at least 30cm.
 - at least 50cm.
 - at least 60cm.
 - at least 80cm.
149. When an aircraft subjected to unlawful interference has landed in a Contracting State, it shall notify by the most expeditious means of the State of Registry and the State of the Operator of the landing and, in addition, shall similarly transmit all other relevant information to:
- each State whose citizens suffered fatalities or injuries, each State whose citizens were detained as hostages, each State whose citizens were known to be on board and ICAO.
 - ICAO only.
 - each State whose citizens were known to be on board only.
 - ICAO and each State whose citizens were known to be on board only.
150. According to JAR-FCL1, recognised instructor categories are:
- FI(A), TRI(A), CRI(A), IRI(A) only.
 - FI(A) and CRI(A) only.
 - FI(A) and IRI(A) only.
 - FI(A), TRI(A), CRI(A), IRI(A), MCCI(A) and SFI(A) only.

Note: FI = Flying Instructor, TRI = Type Rating Instructor, CRI = Class Rating Instructor, IRI = Instrument Rating Instructor, MCCI = Multi-crew Co-operation Instructor, SFI = Synthetic Flight Instructor.

ANSWERS

- | | | | |
|-------|-------|--------|--------|
| 1. A | 41. D | 81. C | 121. B |
| 2. C | 42. C | 82. D | 122. D |
| 3. C | 43. A | 83. A | 123. A |
| 4. C | 44. B | 84. A | 124. A |
| 5. B | 45. A | 85. C | 125. A |
| 6. A | 46. A | 86. B | 126. A |
| 7. D | 47. C | 87. C | 127. D |
| 8. D | 48. D | 88. D | 128. C |
| 9. B | 49. A | 89. B | 129. D |
| 10. B | 50. A | 90. C | 130. D |
| 11. D | 51. D | 91. B | 131. C |
| 12. A | 52. D | 92. A | 132. B |
| 13. C | 53. C | 93. D | 133. A |
| 14. B | 54. C | 94. B | 134. A |
| 15. A | 55. B | 95. B | 135. A |
| 16. B | 56. A | 96. B | 136. B |
| 17. A | 57. A | 97. A | 137. D |
| 18. C | 58. C | 98. A | 138. C |
| 19. B | 59. B | 99. B | 139. A |
| 20. D | 60. A | 100. A | 140. A |
| 21. A | 61. C | 101. B | 141. C |
| 22. A | 62. A | 102. A | 142. C |
| 23. C | 63. A | 103. B | 143. A |
| 24. B | 64. C | 104. A | 144. B |
| 25. D | 65. B | 105. B | 145. A |
| 26. A | 66. D | 106. A | 146. A |
| 27. C | 67. B | 107. A | 147. B |
| 28. D | 68. A | 108. B | 148. B |
| 29. D | 69. B | 109. C | 149. A |
| 30. B | 70. A | 110. D | 150. D |
| 31. D | 71. A | 111. B | |
| 32. D | 72. C | 112. B | |
| 33. A | 73. A | 113. C | |
| 34. B | 74. D | 114. B | |
| 35. D | 75. C | 115. C | |
| 36. D | 76. C | 116. B | |
| 37. A | 77. B | 117. A | |
| 38. D | 78. C | 118. B | |
| 39. D | 79. A | 119. B | |
| 40. B | 80. B | 120. B | |

JAA SPECIMEN EXAMINATION

1. The 'standards' contained in the annexes to the Chicago Convention are to be considered:
 - a. advice and guidance for the aviation legislation within the member states.
 - b. binding for all member states.
 - c. binding for all member states that have not notified ICAO about a national difference.
 - d. binding for all airline companies with international traffic.
2. Which of the annexes deals with the transportation of cargo?
 - a. Annex 9 – Facilitation.
 - b. Annex 18 – Transportation of Dangerous Goods.
 - c. Annex 16 – Environmental Protection.
 - d. Annex 6 – Operation of Aircraft.
3. Which ICAO body furnishes the "Standards and Recommended Practices" (SARPS) for adoption by the Council?
 - a. The Assembly.
 - b. The Regional Air Navigation Meeting.
 - c. The Council itself.
 - d. The Air Navigation Commission.
4. To what did the Tokyo convention of 1963 address itself?
 - a. Licensing of scheduled air services.
 - b. Damage caused by a contracting states aircraft to property in the same state.
 - c. Damage caused by a contracting states aircraft to property in another state.
 - d. Interference with an aircraft in flight.
5. It is suspected that a person on board an aircraft will commit an act that would jeopardise the safety of the aircraft; the PIC may:
 - a. request the crew to detain the passenger.
 - b. ask the passenger to disembark.
 - c. order the other passengers to detain the passenger in question.
 - d. hand him/her over to the authorities.
6. What freedom covers landing and refuelling in another state?
 - a. 1st
 - b. 2nd
 - c. 3rd
 - d. 4th
7. Which of the following is not permitted in the registration mark of an aircraft?
 - a. Four letter Q codes.
 - b. Five letter international identification signals.
 - c. Three letter international identification signals.
 - d. Any number identifying an ICAO document.

8. What registration is disallowed because of possible confusion with distress/urgency signals?
- RCC
 - NNN
 - XXX
 - ZZZ
9. You can use simulator hours towards the 1500 hours required for an ATPL. How are simulator hours are limited?
- Maximum of 100, not more than 15 in a procedural flight trainer.
 - Maximum of 100, not more than 30 in a procedural flight trainer.
 - Maximum of 100, not more than 25 in a procedural flight trainer.
 - Maximum of 100, not more than 50 in a procedural flight trainer.
10. The holder of a pilot licence when acting as co-pilot under supervision of the PIC and performing the functions and duties of the PIC shall be entitled to be credited:
- with 50% of the flight time towards the total time required for a higher grade of licence.
 - in full, but not more than 300hrs towards the total time require for a higher grade of licence.
 - the flight time in full towards the total time required for a higher grade of licence.
 - the flight in full toward the total time required for a higher grade of pilot licence according to the requirements of the licensing authority.
11. For an ATPL(A), how many night hours are required:
- 30.
 - 75.
 - 100.
 - 150.
12. When you are a newly qualified flying instructor (A) you have to be supervised by a senior flying instructor. When will supervision cease?
- Once you have passed a competency check.
 - When you have completed 100 hours instruction and sent 25 students solo.
 - When you have completed 100 hours instruction and sent 100 students solo.
 - When you have completed 100 hours solo.
13. How long would a non JAA licence be valid for if validated for use in a JAA state?
- 6 months.
 - 12 months.
 - 12 months if still valid in the State of Issue.
 - 3 months.

14. What is the period of validity of a PPL class 2 medical in according to JAR FCL 3?
- 24 months until age 30, then 24 months until 50, then 12 months until 65, then 6 months thereafter.
 - 24 months until age 30, then 24 months until 50, then 12 months until 65.
 - 60 months until age 30, then 24 months until 50, then 12 months until 65, then 6 months thereafter.
 - 60 months until age 30, then 24 months until 50, then 12 months until 65.
15. Which of the following requires a class rating:
- multi engine turbine.
 - single pilot multi-engined turbine.
 - microlight with fixed wings and able to move its surfaces in three dimensions.
 - touring motor glider.
16. A CPL applicant undergoing integrated flight training shall be completed:
- 150 hours flight time including 10 hours instrument ground time.
 - 150 hours flight time.
 - 200 hours flight time including 10 hours instrument ground time.
 - 200 hours flight time.
17. How many hours would you have to spend in a clinic or hospital before you would have to inform the authorities?
- 24 hrs.
 - 20 days.
 - 12 hours.
 - 12 days.
18. Which of the quadrantal levels should be used when true track is 358° ; variation is 3°W and deviation is 5°E :
- FL 75.
 - FL 60.
 - FL 70.
 - FL 65.
19. For VFR flight in class E airspace:
- ATC clearance and two way radio are required.
 - two way radio not required.
 - ATC clearance and/or two way radio are required.
 - ATC clearance is required.
20. What are the VMC limits for class B airspace?
- Clear of cloud and in sight of the surface.
 - 8km flight visibility, 1,000 ft vertically and 1500m horizontally from cloud.
 - 5km flight visibility, 1,000 ft vertically and 1500m horizontally from cloud.
 - The same as class D.

21. What minimum ground visibility is required to enable a SVFR flight to take off from an aerodrome in a CTR?
- 1000m.
 - 1500m.
 - 2000m.
 - 3000m.
22. In a holding pattern, turns are to be made at:
- rate of turn of $3^\circ/\text{sec}$.
 - rate of turn of $3^\circ/\text{sec}$ or 20° bank whichever is lesser.
 - rate of turn of $3^\circ/\text{sec}$ or at a bank angle of 25° whichever is lesser.
 - bank angle of 25° .
23. What is the maximum track guidance distance for a turning departure?
- 10 km.
 - 10 nm.
 - 25 nm.
 - 25 km.
24. Visual circling for a class B aircraft is conducted in visibility not less than:
- 1500m
 - 1600m
 - 2800m
 - 5000m
25. What is the climb gradient required during the intermediate segment of a missed approach?
- 5.5%.
 - 2.5%.
 - 0.8%.
 - 3.3%.
26. The Obstacle clearance in the primary area of an intermediate approach is:
- not more than 150m.
 - reduces from 300 m to 150m.
 - equal to or greater than 300m.
 - 500m in mountainous terrain.
27. In general, for a straight in non-precision approach, the MDA/H will be not less than:
- OCH/A.
 - 200 ft.
 - 350 ft.
 - 400 ft.

28. What is the airspeed for holding area construction for a CAT B aircraft in a hold under normal conditions at 4,250m (14,000 ft)?
- 0.83 Mach.
 - 490 km/hr (265 kts).
 - 315 km/hr (170 kts).
 - 520 km/hr (280 kts).
29. For the intermediate section of a missed approach, what is the minimum obstacle clearance:
- 30m.
 - 100m.
 - 50m.
 - 120m.
30. At what distance does an SRA normally terminate:
- 2nm.
 - 1nm.
 - 3nm.
 - ½ nm.
31. What is the Cat 2 ILS criteria for instrument runways:
- | | | |
|----|--------------|---------------------|
| a. | RVR 300-450m | DH not below 100 ft |
| b. | RVR 200 | DH not below 100 ft |
| c. | RVR 200 | DH not below 200 ft |
| d. | RVR 300 | DH not below 200 ft |
32. What is the MOC for the intermediate missed approach segment?
- 30m.
 - 50m.
 - 120m.
 - 300m.
33. Within what angle of the extended centre line of a runway is a non-precision approach considered to be straight in?
- 10°.
 - 15°.
 - 30°.
 - 40°.
34. The 45° leg of a 45/270° procedure turn for a Cat C aircraft is:
- 1 min.
 - 1 min 15 seconds.
 - 1 min 30 seconds.
 - continued until interception of the glide slope.

35. On a precision approach (ILS), the OCH(A) is based among other standard conditions, on the vertical limits between the flight path of the wheels and the glide path antenna. This should not be more than:
- 6m.
 - 9m.
 - 3m.
 - 12m.
36. What is the lowest OCH on a circling approach for a Cat B aircraft?
- 120m.
 - 135m.
 - 140m.
 - 150m.
37. The Vat for a Category B aircraft is:
- up to 91 kts.
 - 90 to 121 kts inclusive.
 - 141 to 165 kts inclusive.
 - 91 to 120 kts inclusive.
38. When using a DR segment to take up an ILS instrument approach, what is the maximum length of the track that may be used to intercept the localiser?
- 10 nms.
 - 5 nms.
 - 10 minutes.
 - 5 minutes.
39. What Obstacle Clearance is guaranteed at a range greater than 5 nm from the edge of the holding area of a holding pattern?
- 100m.
 - 250 ft.
 - 300 ft.
 - none.
40. The minimum sector altitude gives an obstacle clearance of 300 metres within a certain radius from the navigation aid on which the instrument procedure is based. This radius is:
- 15 nms (28 kms).
 - 30 nms (55 kms).
 - 25 nms (46 kms).
 - 20 nms (37 kms).
41. In what class of airspace are all aircraft separated from one another and VFR is permitted?
- D
 - E
 - A
 - B

42. What is the speed limit below 10,000 ft in Class E airspace?
- 250 kts TAS.
 - 250 kts IAS.
 - not applicable.
 - 200 kts IAS.
43. What is the definition of the Emergency Phase?
- The Distress Phase.
 - The Alarm Phase.
 - The Alert Phase.
 - A generic term meaning as the case maybe the Uncertainty Phase, the Alert Phase or the Distress Phase.
44. FIS is provided to aircraft concerning collision hazards in the following classes of airspace:
- C, D, E, F, G.
 - F and G only.
 - F.
 - A, B, C, D, E, F, G.
45. Danger, Prohibited and Restricted areas must be designated by:
- country identifier, followed by P/D/R, followed by the identifier.
 - country identifier followed by P/D/R.
 - P/D/R followed by the identifier.
 - country identifier followed by numbers.
46. In which class or classes of airspace would essential traffic information be given to VFR traffic about other VFR traffic?
- B
 - BCDE
 - BC
 - BCD
47. The lowest height of a CTA above ground or water is:
- 300m.
 - 150m.
 - 200m.
 - 500m.
48. RNP (Required Navigation Performance) is:
- based on Regional Air Navigation Orders (RANOs).
 - based on RANOs and applied by the state.
 - based on RANOs and applied by the state and ICAO.
 - based on RANOs and applied by the ICAO.

49. In what class of airspace can both IFR and VFR fly and IFR traffic only receives an advisory service for separation?
- F
 - E
 - G
 - D
50. An aircraft has been cleared to land and fails to do so within 5 minutes of the ETA of landing and communications have not been re-established with the aircraft. What phase of the Alerting Service will be declared by the ATSU?
- DETRESFA.
 - INCERFA.
 - ALERFA.
 - EMERGFA.
51. What is the delay for a controlled flight after which a flight plan has to be re-filed?
- 30 minutes EOBT.
 - 30 minutes ETD.
 - 60 minutes EOBT.
 - 60 minutes ETD.
52. What are the contents of section 2 of an AIREP?
- present position and ETA.
 - estimated time over the FIR boundary and endurance.
 - estimated elapsed time (EET) and endurance.
 - ETA and endurance.
53. If you want to descend through the level of another aircraft on the same track, the minimum separation is:
- 20 minutes.
 - 10 minutes.
 - 5 minutes.
 - 15 minute.
54. If two aircraft are using the same VOR, by what lateral distance must the aircraft be separated before one of the two may commence a climb or descent?
- 5 nm.
 - 10 nm.
 - 15 nm.
 - 20 nm.
55. What is the separation standard between aircraft at the same altitude when using DME to determine range from a beacon?
- 10 nm where the first aircraft speed is 40 kts faster than the second.
 - 10 nm where the first aircraft speed is 20 kts faster than the second.
 - 20 nm where the first aircraft speed is 40 kts faster than the second.
 - 20 nm where the first aircraft speed is 20 kts faster than the second.

56. The longitudinal separation minimum, based on time between two aircraft at the same altitude, for which navigation aids can give a frequent determination of position and speed and when the proceeding aircraft has a true airspeed of at least 40 kts higher than the following aircraft, is:
- a. 5 minutes.
 - b. 6 minutes.
 - c. 10 minutes.
 - d. 3 minutes.
57. With the Mach number technique applied what is the longitudinal standard separation between two aircraft of which the preceding aircraft is 0.04M faster than the following aircraft?
- a. 10 minutes.
 - b. 9 minutes.
 - c. 8 minutes.
 - d. 7 minutes.
58. Where an aeroplane is approaching to land, what is the maximum time spacing applied between that aeroplane and any other taking off in any direction?
- a. 3 minutes.
 - b. 5 minutes.
 - c. 10 minutes.
 - d. 2 minutes.
59. On departure a 1 minute separation can be applied if the aircraft fly on diverging tracks immediately after take-off at least:
- a. 45°.
 - b. 15°.
 - c. 30°.
 - d. 20°.
60. For dependant parallel approaches what is the radar separation between two aircraft on the same ILS unless wake turbulence requires a greater separation?
- a. 3 nms.
 - b. 5 nms.
 - c. 1 nm.
 - d. 10 nms.
61. What is separation for a light aircraft taking off after a medium aircraft providing they are both using the same runway?
- a. 5 min.
 - b. 3 min.
 - c. 1 min.
 - d. 2 min.

62. Between two aircraft on the same track what is the minimum radar separation which must be provided for wake turbulence is:
- 4 nms.
 - 2.5 nms.
 - 2 nms.
 - 3 nms.
63. A heavy aircraft has made a missed approach to a runway in the opposite direction to normal take-off. What is the separation required for a light aircraft taking off?
- 2 minutes.
 - 3 minutes.
 - 1 minute.
 - 5 minutes.
64. Radar separation may be applied before an aircraft taking off and a preceding departing aircraft providing the departing aircraft can be identified from the end of the runway within:
- 5nm.
 - 3nm.
 - 2nm.
 - 1nm.
65. What is the minimum radar separation for two aircraft established on the same localiser?
- 5 nm.
 - 5 nm when the first a/c is 20 kts faster than the second.
 - 10 nm.
 - 20 nm.
66. Under normal circumstances, what is the radar separation applied between aircraft at the same altitude?
- 2 nm.
 - 2.5 nm.
 - 3 nm.
 - 5 nm.
67. If radar capability permits the minimum longitudinal separation may be reduced to:
- 5 nms.
 - 4.5 nms.
 - 4 nms.
 - 3 nms.
68. A radar controller can request an aircraft to change speed when it is on the intermediate and final approach phase, except in certain conditions specified by the proper ATS authority. The speed change must not be more than:
- ± 15 kts.
 - ± 8 kts.
 - ± 10 kts.
 - ± 20 kts.

69. The minima that must be applied to aircraft which are landing after a “heavy” or “medium” aircraft complying with wake turbulence separation on a timed approach is:
- light aircraft behind medium aircraft ; 4 minutes.
 - medium aircraft behind medium aircraft ; 2 minutes.
 - medium aircraft behind heavy aircraft ; 3 minutes.
 - medium aircraft behind heavy aircraft ; 2 minutes.
70. An integrated aeronautical information package consists of:
- AIP and amendment service, supplement to the AIP, NOTAMs, Preflight Information Bulletins (PIBs), AICs, checklists and summaries.
 - AIP and amendment service,, NOTAMs, Preflight Information Bulletins (PIBs), AICs, AIRACs, checklists and summaries.
 - AIP and amendment service, supplement to the AIP, NOTAMs, AIRACs, AICs, checklists and summaries.
 - AIP & Supplements, AIRACs, NOTAMs and pre-flight bulletins.
71. AIP supplement’s with extensive text and graphics cover a short period; what is a long period in this respect?
- 1 yr.
 - 2 months.
 - 3 months.
 - 6 months.
72. Regarding the AIS what is the time limit for a checklist of current NOTAMs to be issued?
- 7 days.
 - 14 days.
 - 28 days.
 - one month.
73. Touchdown zone markings are set out in pairs. How many such pairs are required for a runway of 2400m or more?
- 6
 - 4
 - 2
 - 8
74. Which “code letter” has to be chosen to identify a taxiway that has to be used by an aircraft with a wheel-base of 15 metres?
- Code letter E.
 - Code letter C.
 - Code letter B.
 - Code letter D.
75. According to the “Aerodrome Reference Code”, the “codeletter” E indicates a wingspan of:
- 15m to 24m.
 - 36m to 52m.
 - 52m to 65m.
 - 24m to 36m.

76. What length should the approach lighting system for a CATII Calvert design be?
- 900m.
 - 600m.
 - 1200m.
 - 400m.
77. Runway Guard lights are:
- flashing red.
 - flashing yellow.
 - flashing green.
 - steady red.
78. Medium intensity obstacle lighting will normally consist of flashing red lights except that they may be flashing white when used:
- in conjunction with high-intensity obstacle lighting.
 - in conjunction with low-intensity obstacle lighting.
 - in conjunction with runway obstacle lighting.
 - in conjunction with the approach path obstacle lighting.
79. An object of limited mobility (an air bridge for example) is lit by:
- low intensity steady red lights.
 - low intensity flashing red lights.
 - medium intensity steady red lights
 - medium intensity flashing red lights.
80. The level of rescue and fire fighting facilities is dependent upon the category of the aerodrome. What factors determine this category?
- Aeroplane reference field length, wing span and outer main gear wheel span of the largest aircraft using that aerodrome.
 - The length of the longest runway and the area to be covered.
 - The overall length and the fuselage width of the longest aircraft using that aerodrome.
 - The length of the longest runway and total area of hard standings including access roads.
81. On departure, how many copies of the following are required:
- the Gen Dec.
 - the stores list.
 - passenger manifest.
- 2 of each.
 - 2 of 1; 2 of 2; 3 of 3.
 - 2 of 1; 1 of 2; 2 of 3.
 - 1 of 1; 1 of 2; 2 of 3.

82. Who is responsible for the efficient organisation of an efficient SAR service?
- FIC and RCC.
 - RCC and rescue sub-centres.
 - FIC, RCC and ACC.
 - ICAO through regional navigation plans.
83. Using the visual SAR signals the symbol for “we have found all personnel” is:
- ++
 - L L L
 - L L
 - Y
84. According to Annex 17, security is defined as “a combination of measures and human resources intended to safeguard:
- civil aviation operations against acts of unlawful interference”.
 - international civil aviation operations against acts of unlawful interference”.
 - international aviation operations against acts of unlawful interference”.
 - aviation operations against acts of unlawful interference”.
85. When an aircraft has sustained damage, the aircraft must be allowed to resume its flight provided that:
- the state where the aircraft is registered, the state where the aircraft is designed and the state where the prototype of the aircraft is declared to be airworthy, agree that the aircraft is still airworthy.
 - the state where the aircraft is registered is of the opinion that the sustained damage is of such a nature that the aircraft is still airworthy.
 - the state where the aircraft is designed and the state where the prototype of the aircraft is declared to be airworthy, send a message to the state where there aircraft is registered which says that the aircraft is still airworthy.
 - the state where the prototype of the aircraft is declared to be airworthy has informed the state where the aircraft is registered that the sustained damage is of such a nature that the aircraft is still airworthy.

ANSWERS TO SPECIMEN JAA EXAMINATION

1.	C	31.	A	61.	D
2.	A	32.	A	62.	A
3.	D	33.	C	63.	A
4.	D	34.	B	64.	D
5.	D	35.	A	65.	A
6.	B	36.	D	66.	D
7.	B	37.	D	67.	D
8.	C	38.	A	68.	D
9.	C	39.	D	69.	D
10.	C	40.	C	70.	A
11.	C	41.	D	71.	C
12.	B	42.	B	72.	D
13.	C	43.	D	73.	A
14.	C	44.	A	74.	B
15.	D	45.	A	75.	C
16.	B	46.	A	76.	A
17.	C	47.	C	77.	B
18.	C	48.	B	78.	A
19.	B	49.	A	79.	A
20.	D	50.	C	80.	C
21.	B	51.	A	81.	A
22.	C	52.	D	82.	B
23.	A	53.	B	83.	C
24.	C	54.	C	84.	B
25.	B	55.	B	85.	B
26.	B	56.	D		
27.	A	57.	D		
28.	C	58.	B		
29.	A	59.	A		
30.	A	60.	A		

45-Day rule	73
45°/180° Procedure turn	159
80°/260° Procedure turn	160

A

A/7500	223
A/7600	223
A/7700	223
Accident	457
Advisory Airspace	234
Aerodrome Beacon	392
Aerodrome Control.	305
Aerodrome Control Service	247
Aerodrome Obstacles.	411
Aerodrome Reference Code	344
Aerodrome Reference Field Length.	345
Aerodrome Reference Point	348
Aeronautical Beacons.	392
Aeronautical Information	
Circulars (Aics)	326
Aeronautical Part	344
Aeroplane Class Ratings66
Aiming Point Marking	369
Aip Supplements	326
Air-side	344
AIRAC	328
Aircraft Lights.	94
Aircraft Markings.56
Aircraft Stand Markings	374
AIREP	255
AIREP Special	255
AIRMET	251
Air Navigation Commission.28
AIRPROX	255
Air Traffic Advisory Service.	313
Air Traffic Flow Management (ATFM).	250
Air Traffic Incident Reports (ATIR).	255
AIS	325
ALERFA	254
Alerting Service	307
Alert Phase	254
Altimeter Accuracy	201
Altimeter Setting Procedures	197
Altitude90
Annex 1 To 1829
Anti Collision Lights95
Applicable Law22
Approach Control Service	247
Apron	344
Apron Management Service.	417
Apron Safety Lines	371
Area Control Centre (ACC)	231
Area Control Service	247
ARP.	348
Arrival Segment.	150

Article 37.	425
Article 38.24
ASDA	349
ASHTAM	332
Assembly27
ATC Clearance98
ATC Clearances	248
ATCU.	234
ATIS	252
ATPL(A)69
Authority Of The Commander32
Automatic Dependent Surveillance (ADS)	254

B

Barrettes	392
Base Checks74
Base Turn	161
Basic Instrument Flight Trainer64
Bermuda Agreement31
Bilateral Agreements23

C

Cabotage23
Calculation Of Da/h	156
Calculation Of Mda/h	157
Calvert System	392
Categories Of Aircraft	147
Certificate Of Airworthiness.49
Certificates Of Airworthiness26
Changing From Ifr To Vfr	106
Chicago Convention21
Circling.	149, 178
Clearance To Maintain Own Separation In VMC.	267
Clearways	353
CMC	427
Co-ordinated Universal Time98
Co-pilot63
C of A.49
Combination Signs	380
Commander63
Commercial Freedoms30
Commissions And Committees28
Common Mark55
Common Mark Registering Authority.55
Communications Failure.	100
Composite Separation	265
Control Areas (CTAS)	231
Controlled Airspace (CAS).	234
Control Zones (CTRS)	231
Council.27
CPL(A)68
Crew Members' Certificates	427
Cross Country Flight Time.69

Cruising Levels 90
 Customs And Excise 24

D

Danger Area 111
 Dangerous Cargo 25
 Delays 284
 Deportees 445
 Deportees And Persons In Custody. 445
 Descent Gradient 158
 DETRESFA. 254
 Direct Entry 190
 Directive 94/56 461
 Distress. 110
 Distress Phase 254
 Document 4444 247

E

EASA. 34
 ECAC. 34
 EET 106
 Emergency Descent. 314
 Emergency Frequencies 110
 Emergency Phase 433
 Emergency Vehicles 250, 413
 En-route Obstacles 415
 Essential Traffic Information 265
 Eurocontrol 36
 European Aviation Safety Agency 34
 European Civil Aviation Conference 34

F

Facilitation. 24
 FAF 154
 FAP 154
 Final Segment 150
 Fixed Distance Markers 384
 Flight Crew Licences 26
 Flight Deck Signals 120
 Flight Information Centre 231
 Flight Information Regions (FIR) 231
 Flight Information Service (FIS) 234
 Flight Information Service
 Officers (FISOS) 251
 Flight Levels. 90
 Flight Plans 97
 Flight Procedures Trainer 64
 Flight Simulator. 64
 Flight Strips 299
 Flight Time 63
 Freedoms Of The Air 23
 Fuel Jettison 314

G

General Declaration 425
 General Rules 89
 Geneva Convention. 36
 Geographical Separation. 268

Ground-air Visual Signal Code 436
 Ground Control 248

H

Hague Convention 31
 High Intensity Lights. 414
 High Seas 22
 Holding Area 192
 Horizontal Separation 267

I

IATA 33
 ICAO 21, 27
 ICAO Precision Approach CAT I
 Lighting System. 394
 ICAO Secretariat 28
 Identification Beacon 392
 IFR 87
 ILS 148
 Inadmissible Persons 447
 INCEFA 253
 Incident 458
 Information Signs. 378
 Initial Segment 150
 Instructor & Examiner Rating 70
 Instructor Rating 67
 Instrument Ground Time 63
 Instrument Rating (Aeroplane) 70
 Instrument Runway 351
 Instrument Time 69
 Integrated Aeronautical
 Information Package 326
 Interception Of Civil Aircraft 101
 Interception Phraseology 102
 Intermediate Holding Position
 Marking 374
 Intermediate Segment 150
 International Airports 343
 International Air Services Transit
 Agreement. 23
 International Air Transport
 Agreement. 23
 International Air Transport
 Association 33
 International Civil Aviation
 Organisation. 21
 International Conference On
 Civil Aviation 21
 Investigation. 458
 Investigations 459

- IR(A) 70
Isolated Aircraft Parking Position. 359
- J**
- JAA 35
JAA Theoretical Knowledge Examinations .74
JAR-FCL 63
Joint Aviation Authorities 35
- L**
- Land After Clearance. 306
Lateral Separation 268
Law Enforcement Officers 444
LDA 349
Line Checks 74
Location Signs. 378
Longitudinal Separation 269
Lowest Useable Flight Level. 197
Low Intensity Lights 414
Low Visibility Operations 250
- M**
- Mach Meter 50
Mandatory Instruction Signs 376
Manifests. 427
Manoeuvring Area 344
Marshalling Signals. 119
Medical Report Periods 65
Medium Intensity Lights. 414
MEHT 399
Minimum Eye Height 399
Minimum Sector Altitude 139
Missed Approach 163
Missed Approach Procedure 150
MOC 151
Mode 1: Independent Parallel
Approaches 209
Mode 2: Dependent Parallel
Approaches 210
Mode 3: Simultaneous Instrument
Departures. 212
Mode 4: Segregated Departures/
Arrivals 213
Montreal Convention. 31
Mountainous Terrain. 136
Movement Area 344
MPL 70
MSA 139
Multi-crew Pilot Licence 70
Multi-pilot Operations 69
- N**
- Nationality Mark 55
NDB 149
Night Flight Time. 69
- Non-scheduled Flights 23
Non Precision Procedures 149
Normal Operating Zone (NOZ). 214
NOTAM 326
No Transgression Zone (NTZ) 214
- O**
- Obstacle Identification Surfaces. 411
OCA/H. 155
Oceanic Control Areas (OCAS) 232
OFIS 252
OIS 411
Open FIR. 231
Outer Main Gear Wheel Span 345
- P**
- PANS. 29
PANS ATM 247
PAPI 399
PAR. 303
Parallel Entry 189
Paris Convention 55
Passenger Baggage 427
Passengers 444
PDG 136
Persons In Custody 445
PIBS. 326
PIC 63
Pilot-in-command. 63
Pilot Proficiency Checks 74
Potentially Disruptive Passengers 445
PPL(A) 68
Pre-flight Altimeter Check
Location 348
Precision Approach. 148
Precision Approach Category II/III
Lighting System. 396
Precision Approach CAT I Lighting
System 393
Precision Approach Path Indicators (PAPI) 398
Procedural Separation 299
Procedural Wake Turbulence
Separation 277
Procedure Turn 159
Prohibited, Restricted And Danger Areas . 232
Prohibited Area 111
Proximity And Right Of Way 91
Pyroclastic Ash Plume/cloud 333
- Q**
- QDM 368
QFE. 197
QNE 198
QNH 197

R

Racetrack Procedure 162
 Radar 299
 Radar Separation Standard 277
 Radar Vectoring 302
 Radar Vectoring Area (RVA) 302
 Radar Wake Turbulence Separation 282
 Radio Altimeter Operating Area 354
 RAN 29
 Rapid Exit Taxiways 355
 RCC 433
 Reduced Radar Separation 277
 Regional Air Navigation 29
 Regional Supplementary Procedures 30
 Registration Mark 55
 Required Navigation Performance (RNP) 236
 Rescue And Fire Fighting 416
 Rescue Co-ordination Centre 433
 Resolution Advisories (RAS) 225
 Responses By Intercepted Aircraft 103
 Response Time 417
 Restricted Areas 111
 RFF 416
 Right Of Way 91
 RNAV 140, 167
 Rome Convention 33
 Rules Of The Air 87
 Runway-holding Position Marking 372
 Runway-holding Positions 357
 Runway Centre Line Lights 400
 Runway Centre Line Marking 368
 Runway Designation Marking 367
 Runway Edge Lights 400
 Runway End Lights 400
 Runway End Safety Area (RESA) 353
 Runway Guard Lights 403
 Runways 351
 Runway Side Stripe Marking 371
 Runway Strips 352
 Runway Surface Description 332
 Runway Threshold And Wing Bar Lights 400
 Runway Touchdown Zone Lights 400
 RVSM 108, 109

S

SARPS 25
 Scheduled Flight 23
 Search And Rescue 24
 Sector 1 (Parallel Entry) 189
 Sector 2 (Offset Entry) 190
 Sector 3 (Direct Entry) 190
 Security 443
 Semi-circular Flight Rules 108
 Separation Minima 277
 Serious Incident 458
 Serious Injury 458

Shuttle 191
 Signal Area 366
 Signalling Lamp 365
 Signals Area 114
 Signals By Intercepting Aircraft 103
 Simple Approach Lighting System 393
 Simulated IMC 95
 Simultaneous Parallel
 Instrument Approaches 209
 SNOWCLO 331
 SNOWTAM 330
 Sovereignty 22
 Special VFR 109
 Speed Limit 234
 Squawk IDENT 223
 SRA 149, 304
 SSR 110
 Stabilised Approach 155
 Standards And Recommended
 Practices 21
 State Of Design 458
 State Of Manufacture 49, 458
 State Of Occurrence 458
 State Of Registry 49
 Stop Bars 94, 401
 Stopway Lights 400
 Stopways 353
 Straight-in Approach 150
 Straight Departure 138
 Structural Integrity Programme 49
 Student Pilot 68
 Suzerainty 22
 SVFR 109
 Synthetic Flight Trainer 64
 System Minima 148

T

Taxiway Centre Line Lights 401
 Taxiway Centre Line Marking 372
 Taxiway Edge Lighting 401
 Taxiways 354
 Technical Freedoms 30
 Territorial Airspace 22
 Territory 22
 The Air Traffic Services (ATS) 247
 The Chicago Convention 21
 The Visual Manoeuvring (Circling) Area 179
 Threshold Marking 368
 Time Based Longitudinal Separation 270
 TODA 349
 Tokyo Convention 31
 TORA 348
 Touchdown Zone Marking 370
 Track Reversal 159
 Track Separation 268
 Traffic Advisories (TAS) 225

Transition	199
Transition Altitude	199
Transition Layer.	200
Transition Level.	200
Transponder Failure	224
Transverse Stripe	369
Turning Departure	138
Type Ratings66

U

Uncertainty Phase	253
Unlawful Interference	101
Upper Information Regions (UIRS).	231
Urgency	110
UTC98

V

Vertical Separation During Ascent Or Descent	267
Vertical Separation Minima	265
Visual Approach	149
Visual Manoeuvring (Circling)	149
Visual Manoeuvring (Circling) Area	179
Visual Runway	350
Visual Separation	282
Visual Signals	113
VMC70
VMC Criteria88
Voice - ATIS	252
VOR	149

W

Wake Turbulence Categories	278
Warsaw Convention33
Wheel Braking On Wet Runways	331
Wind Direction Indicator	365

